



YAMAHA

2014

SERVICE MANUAL

**YF70GE
YF70GPE
YF70GPHE
YF70GPSE
YF70GPLE
YFM700DE
YFM700PE
YFM700PHE
YFM700PSE
YFM700PLE**

**GRIZZLY
700**

EAS20040

**YF70GE/YF70GPE/YF70GPHE/
YF70GPSE/YF70GGLE/
YFM700DE/YFM700PE/YFM700PHE/
YFM700PSE/YFM700PLE
SERVICE MANUAL**

©2013 by Yamaha Motor Co., Ltd.

First edition, May 2013

All rights reserved.

**Any reproduction or unauthorized use
without the written permission of
Yamaha Motor Co., Ltd.
is expressly prohibited.**

IMPORTANT

This manual was produced by the Yamaha Motor Company, Ltd. primarily for use by Yamaha dealers and their qualified mechanics. It is not possible to include all the knowledge of a mechanic in one manual. Therefore, anyone who uses this book to perform maintenance and repairs on Yamaha vehicles should have a basic understanding of mechanics and the techniques to repair these types of vehicles. Repair and maintenance work attempted by anyone without this knowledge is likely to render the vehicle unsafe and unfit for use.

This model has been designed and manufactured to perform within certain specifications in regard to performance and emissions. Proper service with the correct tools is necessary to ensure that the vehicle will operate as designed. If there is any question about a service procedure, it is imperative that you contact a Yamaha dealer for any service information changes that apply to this model. This policy is intended to provide the customer with the most satisfaction from his vehicle and to conform to federal environmental quality objectives.



Yamaha Motor Company, Ltd. is continually striving to improve all of its models. Modifications and significant changes in specifications or procedures will be forwarded to all authorized Yamaha dealers and will appear in future editions of this manual where applicable.

TIP

- This Service Manual contains information regarding periodic maintenance to the emission control system. Please read this material carefully.
- Designs and specifications are subject to change without notice.

IMPORTANT MANUAL INFORMATION

Particularly important information is distinguished in this manual by the following notations.

	<p>This is the safety alert symbol. It is used to alert you to potential personal injury hazards. Obey all safety messages that follow this symbol to avoid possible injury or death.</p>
	<p>A WARNING indicates a hazardous situation which, if not avoided, could result in death or serious injury.</p>
	<p>A NOTICE indicates special precautions that must be taken to avoid damage to the vehicle or other property.</p>
<p>TIP</p>	<p>A TIP provides key information to make procedures easier or clearer.</p>

HOW TO USE THIS MANUAL

This manual is intended as a handy, easy-to-read reference book for the mechanic. Comprehensive explanations of all installation, removal, disassembly, assembly, repair and check procedures are laid out with the individual steps in sequential order.

- The manual is divided into chapters and each chapter is divided into sections. The current section title "1" is shown at the top of each page.
- Sub-section titles "2" appear in smaller print than the section title.
- To help identify parts and clarify procedure steps, there are exploded diagrams "3" at the start of each removal and disassembly section.
- Numbers "4" are given in the order of the jobs in the exploded diagram. A number indicates a disassembly step.
- Symbols "5" indicate parts to be lubricated or replaced.
- Refer to "SYMBOLS".
- A job instruction chart "6" accompanies the exploded diagram, providing the order of jobs, names of parts, notes in jobs, etc.
- Jobs "7" requiring more information (such as special tools and technical data) are described sequentially.

1
↓
CYLINDER AND PISTON

CYLINDER AND PISTON

Removing the cylinder and piston

1st 15 Nm (1.5 m·kg, 11 ft·lb)
2nd 50 Nm (5.0 m·kg, 36 ft·lb)

10 Nm (1.0 m·kg, 7.2 ft·lb)

3
4
5
6

Order	Job/Parts to remove	Q'ty	Remarks
	Cylinder head		Refer to "CYLINDER HEAD" on page 5-10
	Water jacket joint		Refer to "WATER PUMP" on page 6-7.
1	Timing chain guide (exhaust side)	1	
2	Cylinder	1	
3	Cylinder gasket	1	
4	Dowel pin	2	
5	Piston pin clip	2	
6	Piston pin	1	
7	Piston	1	
8	Top ring	1	
9	2nd ring	1	
10	Oil ring	1	
			For installation, reverse the removal procedure.

5-28

CYLINDER AND PISTON

REMOVING THE PISTON

1. Remove:

- Piston pin clips "1"
- Piston pin "2"
- Piston "3"

NOTICE

Do not use a hammer to drive the piston pin out.

TIP

- Before removing the piston pin clips, cover the crankcase opening with a clean rag to prevent the piston pin clips from falling into the crankcase.
- Before removing the piston pin, deburr the piston pin clip grooves and the piston pin bore areas. If both areas are distorted and the piston pin is still difficult to remove, remove it with the piston pin puller set "4".

Piston pin puller set
9039D-01304
Piston pin puller
YU-01304

2. Remove:

- Top ring
- 2nd ring
- Oil ring

TIP

When removing a piston ring, open the end gap with your fingers and lift the other side of the ring over the piston crown.

CHECKING THE CYLINDER AND PISTON

1. Check:

- Piston wall
- Cylinder wall

Vertical scratches → Replace the cylinder, and replace the piston and piston rings as a set.

2. Measure:

- Piston-to-cylinder clearance

a. Measure cylinder bore "C" with the cylinder bore gauge.

TIP

Measure cylinder bore "C" by taking side-to-side and front-to-back measurements of the cylinder. Then, find the average of the measurements.

5-29

SYMBOLS

The following symbols are used in this manual for easier understanding.

TIP

The following symbols are not relevant to every vehicle.



















SYMBOL	DEFINITION	SYMBOL	DEFINITION
	Serviceable with engine mounted		Gear oil
	Filling fluid		Molybdenum disulfide oil
	Lubricant		Brake fluid
	Special tool		Wheel bearing grease
	Tightening torque		Lithium-soap-based grease
	Wear limit, clearance		Molybdenum disulfide grease
	Engine speed		Silicone grease
	Electrical data		Apply locking agent (LOCTITE®).
	Engine oil		Replace the part with a new one.

TABLE OF CONTENTS

GENERAL INFORMATION	1
SPECIFICATIONS	2
PERIODIC CHECKS AND ADJUSTMENTS	3
CHASSIS	4
ENGINE	5
COOLING SYSTEM	6
FUEL SYSTEM	7
DRIVE TRAIN	8
ELECTRICAL SYSTEM	9
TROUBLESHOOTING	10

GENERAL INFORMATION

IDENTIFICATION	1-1
VEHICLE IDENTIFICATION NUMBER	1-1
MODEL LABEL.....	1-1
FEATURES	1-2
OUTLINE OF THE FI SYSTEM.....	1-2
FI SYSTEM.....	1-3
OUTLINE OF THE EPS (ELECTRIC POWER STEERING) SYSTEM (for EPS models)	1-5
EPS (ELECTRIC POWER STEERING) SYSTEM BLOCK DIAGRAM (for EPS models)	1-7
INSTRUMENT FUNCTIONS	1-9
IMPORTANT INFORMATION	1-11
PREPARATION FOR REMOVAL AND DISASSEMBLY.....	1-11
REPLACEMENT PARTS.....	1-11
GASKETS, OIL SEALS AND O-RINGS	1-11
LOCK WASHERS/PLATES AND COTTER PINS	1-11
BEARINGS AND OIL SEALS	1-12
CIRCLIPS	1-12
RUBBER PARTS.....	1-12
BASIC SERVICE INFORMATION	1-13
QUICK FASTENERS.....	1-13
ELECTRICAL SYSTEM.....	1-14
SPECIAL TOOLS	1-18

EAS20130

IDENTIFICATION

EAS20140

VEHICLE IDENTIFICATION NUMBER

The vehicle identification number "1" is stamped into the front left side of the frame.

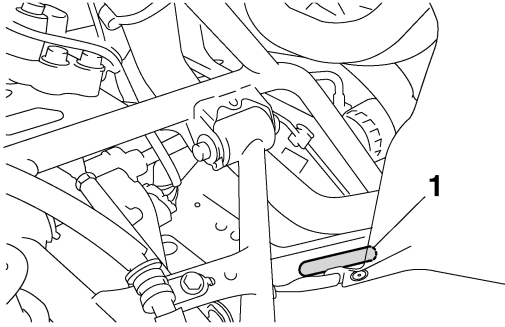

EAS20150

MODEL LABEL

The model label "1" is affixed to the location shown in the illustration. This information will be needed to order spare parts.

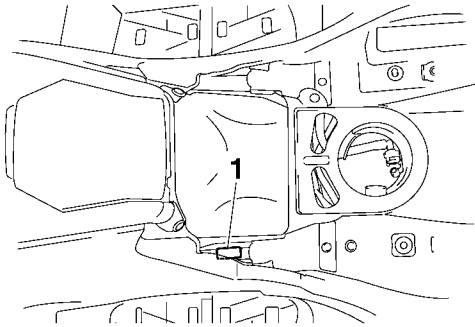

EAS20170

FEATURES

EAS28P1031

OUTLINE OF THE FI SYSTEM

The main function of a fuel supply system is to provide fuel to the combustion chamber at the optimum air-fuel ratio in accordance with the engine operating conditions and the atmospheric temperature. In the conventional carburetor system, the air-fuel ratio of the mixture that is supplied to the combustion chamber is created by the volume of the intake air and the fuel that is metered by the jet used in the respective carburetor.

Despite the same volume of intake air, the fuel volume requirement varies with the engine operating conditions, such as acceleration, deceleration, or operating under a heavy load. Carburetors that meter the fuel through the use of jets have been provided with various auxiliary devices, so that an optimum air-fuel ratio can be achieved to accommodate the constant changes in the operating conditions of the engine.

As the requirements for the engine to deliver more performance and cleaner exhaust gases increase, it becomes necessary to control the air-fuel ratio in a more precise and finely tuned manner. To accommodate this need, this model has adopted an electronically controlled fuel injection (FI) system, in place of the conventional carburetor system. This system can achieve an optimum air-fuel ratio required by the engine at all times by using a microprocessor that regulates the fuel injection volume according to the engine operating conditions detected by various sensors.

The adoption of the FI system has resulted in a highly precise fuel supply, improved engine response, better fuel economy, and reduced exhaust emissions.

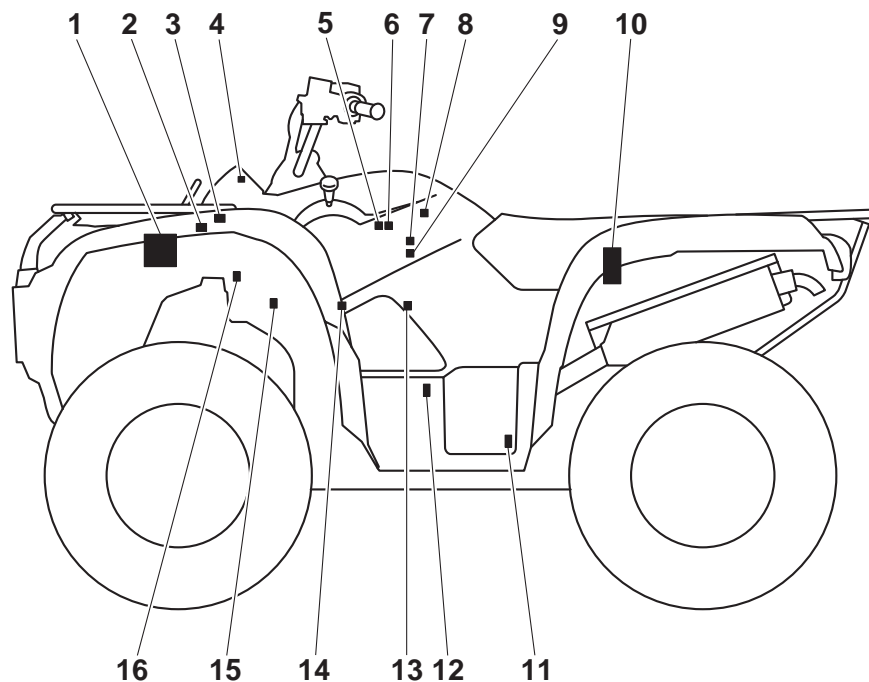

- | | |
|-----------------------------------|--------------------------------|
| 1. ECU (engine control unit) | 9. Fuel injector |
| 2. Lean angle sensor | 10. Fuel pump |
| 3. Fuel injection system relay | 11. Speed sensor |
| 4. Engine trouble warning light | 12. Crankshaft position sensor |
| 5. ISC (idle speed control) unit | 13. Coolant temperature sensor |
| 6. Intake air pressure sensor | 14. Spark plug |
| 7. TPS (throttle position sensor) | 15. Ignition coil |
| 8. Intake air temperature sensor | 16. Air cut-off valve |

EAS28P1032

FI SYSTEM

The fuel pump delivers fuel to the fuel injector via the fuel filter. The pressure regulator maintains the fuel pressure that is applied to the fuel injector at only 324 kPa (3.24 kgf/cm², 46.1 psi). Accordingly, when the energizing signal from the ECU energizes the fuel injector, the fuel passage opens, causing the fuel to be injected into the intake manifold only during the time the passage remains open. Therefore, the longer the length of time the fuel injector is energized (injection duration), the greater the volume of fuel that is supplied. Conversely, the shorter the length of time the fuel injector is energized (injection duration), the lesser the volume of fuel that is supplied.

The injection duration and the injection timing are controlled by the ECU. Signals that are input from the throttle position sensor, crankshaft position sensor, intake air pressure sensor, intake air temperature sensor, coolant temperature sensor, lean angle sensor and speed sensor enable the ECU to determine the injection duration. The injection timing is determined through the signals from the crankshaft position sensor. As a result, the volume of fuel that is required by the engine can be supplied at all times in accordance with the driving conditions.

Illustration is for reference only.

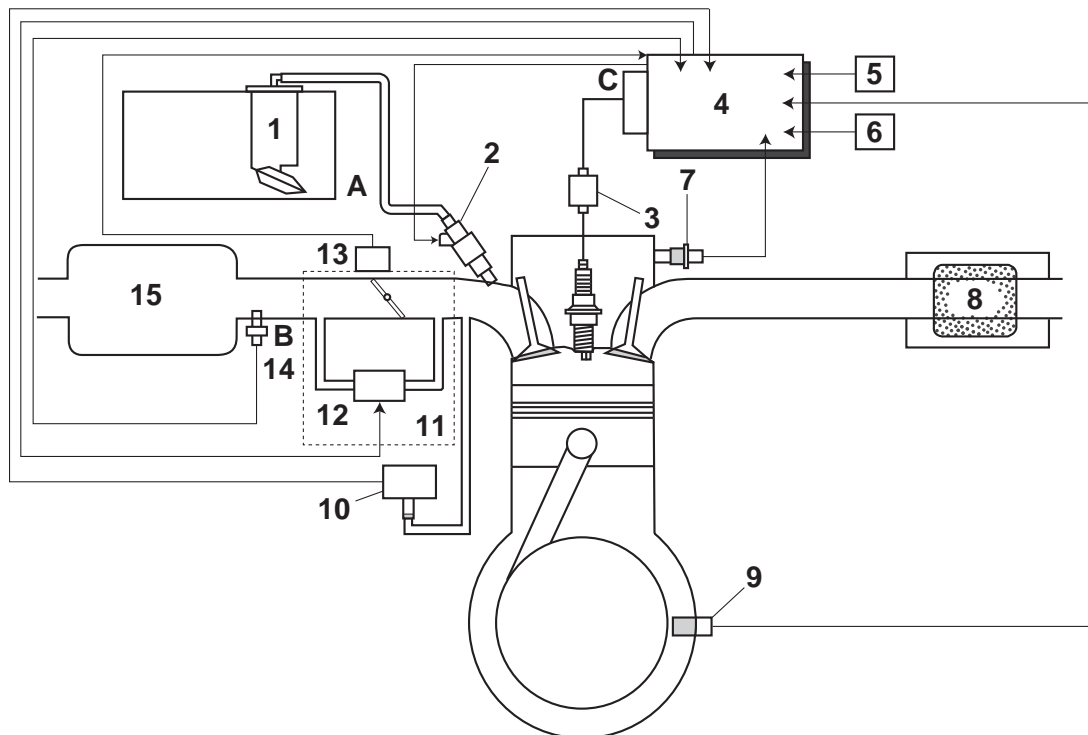

- | | |
|-----------------------------------|-----------------------------------|
| 1. Fuel pump | 13. Throttle position sensor |
| 2. Fuel injector | 14. Intake air temperature sensor |
| 3. Ignition coil | 15. Air filter case |
| 4. ECU (engine control unit) | A. Fuel system |
| 5. Speed sensor | B. Air system |
| 6. Lean angle sensor | C. Control system |
| 7. Coolant temperature sensor | |
| 8. Catalytic converter | |
| 9. Crankshaft position sensor | |
| 10. Intake air pressure sensor | |
| 11. Throttle body | |
| 12. ISC (idle speed control) unit | |

EAS1HPG015

OUTLINE OF THE EPS (ELECTRIC POWER STEERING) SYSTEM (for EPS models)

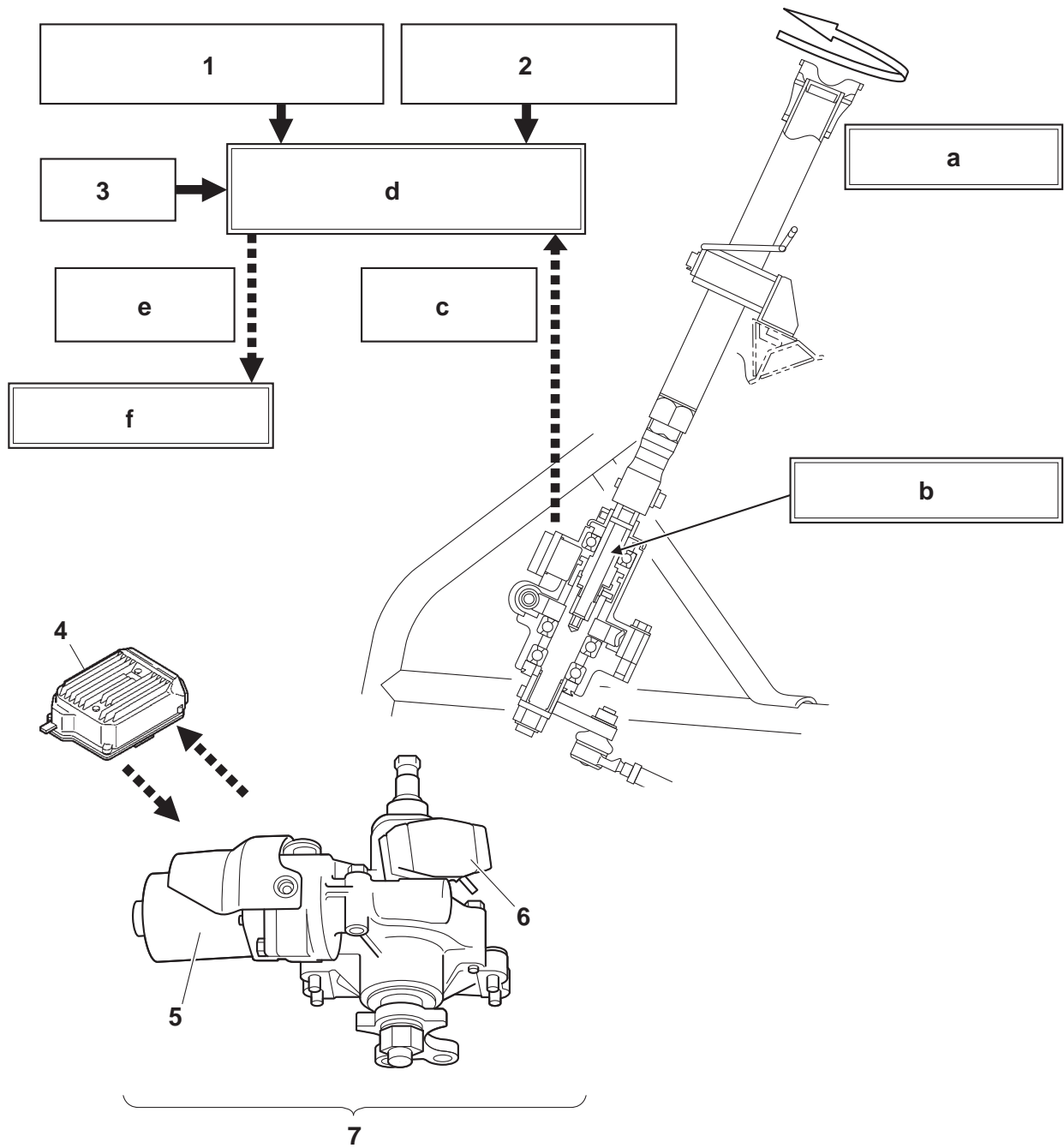

FEATURES

1. Speed information from speed sensor
2. Engine starting RPM information from ECU
3. Battery
4. EPS control unit
5. EPS motor
6. Torque sensor
7. EPS unit
 - a. Operates steering
 - b. Twists torsion bar
 - c. Sends the torque sensor signal
 - d. EPS control unit calculates assist power
 - e. Electricity output switched by EPS control unit
 - f. Activates EPS motor

ECA28P1027

NOTICE

To prevent accidental damage to the EPS unit, it must not be disassembled.

EAS1HPG016

EPS (ELECTRIC POWER STEERING) SYSTEM BLOCK DIAGRAM (for EPS models)

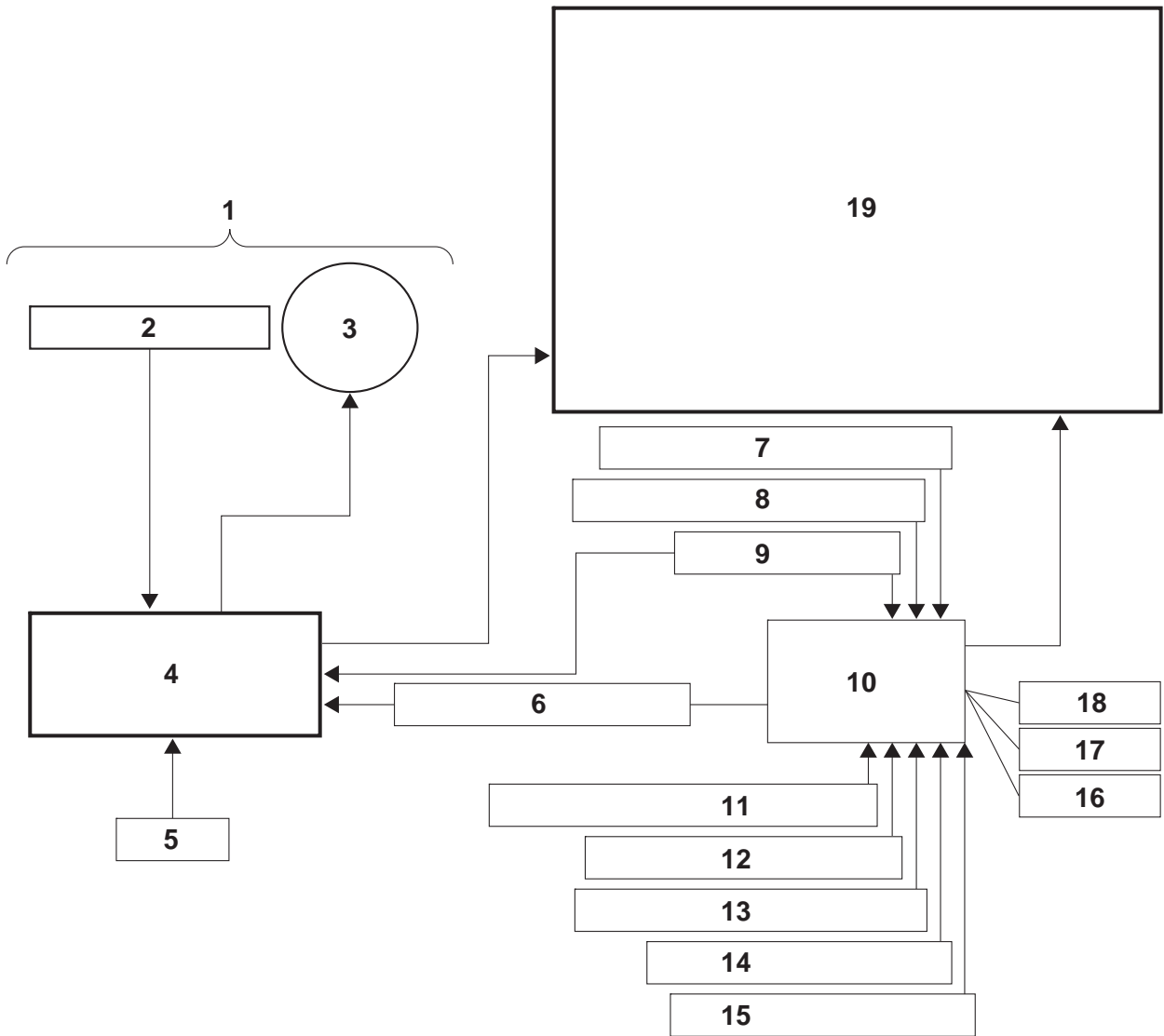

1. EPS unit
2. Torque sensor
3. EPS motor
4. EPS control unit
5. Battery
6. Engine rpm signal
7. Coolant temperature sensor signal
8. Crankshaft position sensor signal
9. Speed sensor signal
10. ECU (engine control unit)
11. Intake air temperature sensor signal
12. Throttle position sensor signal
13. Intake air pressure sensor signal
14. Lean angle sensor signal
15. On-command four-wheel-drive motor switch and differential lock switch signal
16. Ignition coil
17. Fuel pump
18. Fuel injector
19. Meter assembly
 - Multifunction display: Speedometer/Odometer/Tripmeter A/Trip meter B/Clock/Fuel meter/Gear position
 - Indicator and warning lights: EPS warning/Engine trouble warning/Coolant temperature warning/Reverse indicator/Neutral indicator/Park indicator/High-range indicator/Low-range indicator/Differential lock
 - FI and EPS self-diagnostic fault codes

EAS28P1035

INSTRUMENT FUNCTIONS

Multifunction display

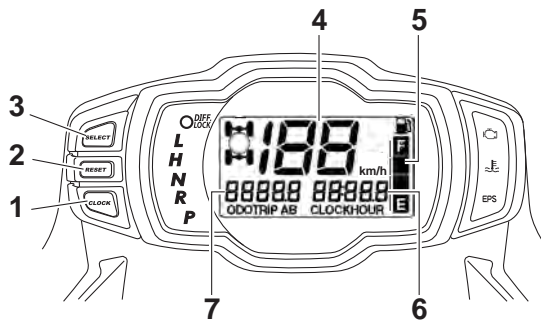

1. "CLOCK" button
2. "RESET" button
3. "SELECT" button
4. Speedometer
5. Fuel meter
6. Clock/Hour meter
7. Odometer/Tripmeter A/Tripmeter B

The multifunction display is equipped with the following:

- a speedometer (which shows the riding speed)
- an odometer (which shows the total distance traveled)
- two tripmeters (which show the distance traveled since they were last set to zero)
- a clock
- an hour meter (which shows the total time the engine has been running)
- a fuel meter
- a self-diagnosis device

Odometer and tripmeter modes

Pushing the "SELECT" button switches the display between the odometer mode "ODO" and the tripmeter modes "A" and "B" in the following order:

ODO → TRIP A → TRIP B → ODO

To reset a tripmeter, select it by pushing the "SELECT" button, and then push the "RESET" button for at least three seconds. The tripmeters can be used to estimate the distance that can be traveled with a full tank of fuel. This information will enable you to plan future fuel stops.

TIP

Pushing and holding in the "SELECT" button, and turning the key to "ON" while the button is pushed, switches the display between "mph" and "km/h".

Clock mode

Pushing the "CLOCK" button switches the display between the clock mode "CLOCK" and the hour meter mode "HOUR" in the following order: CLOCK → HOUR → CLOCK

To set the clock:

1. Set the display to the clock mode.
2. Push the "SELECT" button and "RESET" button together for at least three seconds.
3. When the hour digits start flashing, push the "RESET" button to set the hours.
4. Push the "SELECT" button, and the minute digits will start flashing.
5. Push the "RESET" button to set the minutes.
6. Push the "SELECT" button and then release it to start the clock.

Fuel meter

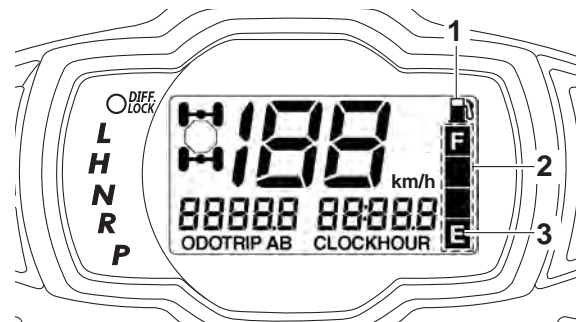

1. Fuel level warning indicator
2. Fuel meter
3. "E" segment

The fuel meter indicates the amount of fuel in the fuel tank. The display segments of the fuel meter disappear from "F" (full) towards "E" (empty) as the fuel level decreases. When the "E" segment disappears and the fuel level warning indicator flashes, refuel as soon as possible.

TIP

This fuel meter is equipped with a self-diagnosis system. If the electrical circuit is defective, all the display segments and fuel level warning indicator will start flashing. If this occurs, check the electrical circuit.

Refer to "SIGNALING SYSTEM" on page 9-19.

Self-diagnosis device

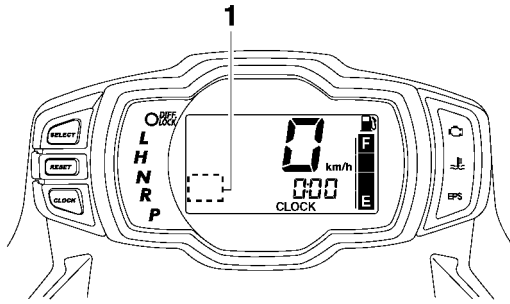

1. Fault code display

This model is equipped with a self-diagnosis device for various electrical circuits.

If any of those circuits are defective, the multifunction display will indicate a two-digit fault code. If the multifunction display indicates such a fault code, note the code number, and check the vehicle.

ECA28P1028

NOTICE

If the multifunction display indicates a fault code, the vehicle should be checked as soon as possible in order to avoid engine damage.

EAS20180

IMPORTANT INFORMATION

EAS20190

PREPARATION FOR REMOVAL AND DISASSEMBLY

1. Before removal and disassembly, remove all dirt, mud, dust and foreign material.



2. Use only the proper tools and cleaning equipment.

Refer to "SPECIAL TOOLS" on page 1-18.

3. When disassembling, always keep mated parts together. This includes gears, cylinders, pistons and other parts that have been "mated" through normal wear. Mated parts must always be reused or replaced as an assembly.

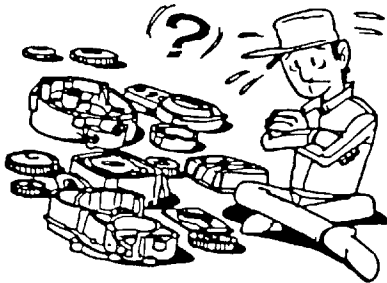

4. During disassembly, clean all of the parts and place them in trays in the order of disassembly. This will speed up assembly and allow for the correct installation of all parts.
5. Keep all parts away from any source of fire.

EAS20200

REPLACEMENT PARTS

Use only genuine Yamaha parts for all replacements. Use oil and grease recommended by Yamaha for all lubrication jobs. Other brands may be similar in function and appearance, but inferior in quality.

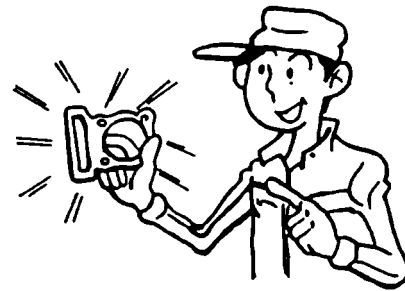

EAS20210

GASKETS, OIL SEALS AND O-RINGS

1. When overhauling the engine, replace all gaskets, seals and O-rings. All gasket surfaces, oil seal lips and O-rings must be cleaned.
2. During reassembly, properly oil all mating parts and bearings and lubricate the oil seal lips with grease.

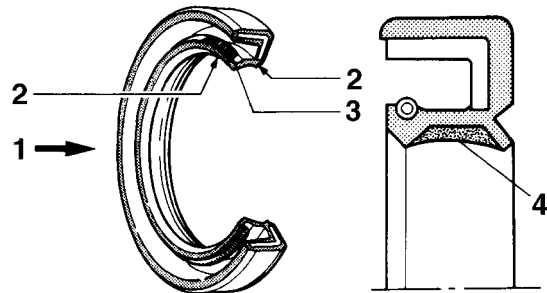

1. Oil
2. Lip
3. Spring
4. Grease

EAS20220

LOCK WASHERS/PLATES AND COTTER PINS

After removal, replace all lock washers/plates "1" and cotter pins. After the bolt or nut has been tightened to specification, bend the lock tabs along a flat of the bolt or nut.

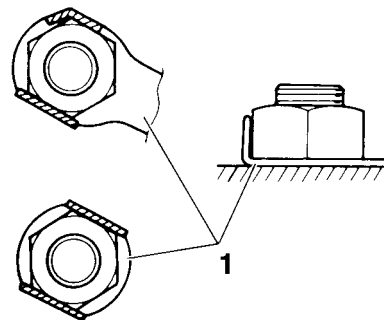

IMPORTANT INFORMATION

EAS20230

BEARINGS AND OIL SEALS

Install bearings "1" and oil seals "2" so that the manufacturer marks or numbers are visible. When installing oil seals "2", lubricate the oil seal lips with a light coat of lithium-soap-based grease. Oil bearings liberally when installing, if appropriate.

ECA13300

NOTICE

Do not spin the bearing with compressed air because this will damage the bearing surfaces.

EAS2BG1003

RUBBER PARTS

Check rubber parts for deterioration during inspection. Some of the rubber parts are sensitive to gasoline, flammable oil, grease, etc. Do not allow any items other than the specified one to contact the parts.

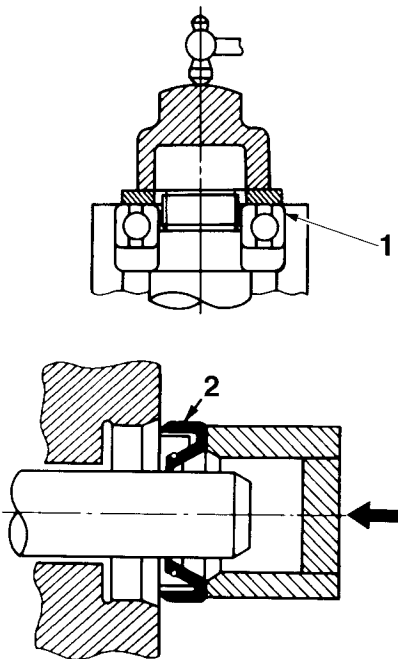

EAS20240

CIRCLIPS

Before reassembly, check all circlips carefully and replace damaged or distorted circlips. Always replace piston pin clips after one use. When installing a circlip "1", make sure the sharp-edged corner "2" is positioned opposite the thrust "3" that the circlip receives.

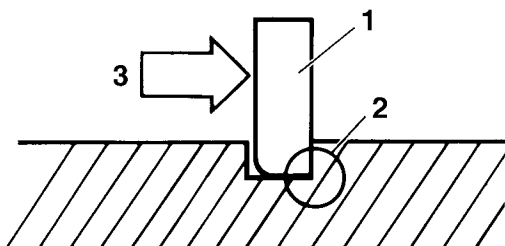

EAS30380

BASIC SERVICE INFORMATION

EAS30390

QUICK FASTENERS

Rivet type

1. Remove:
 - Quick fastener

TIP

To remove the quick fastener, push its pin with a screwdriver, then pull the fastener out.

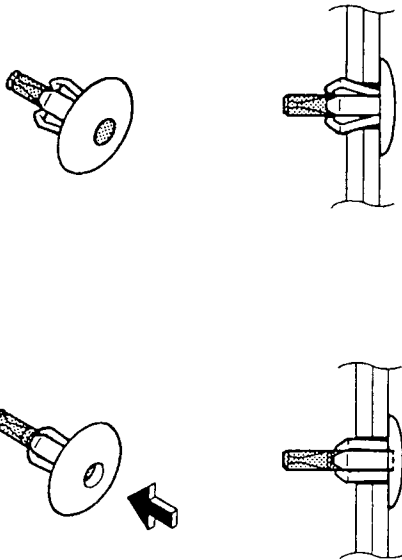

2. Install:

- Quick fastener

TIP

To install the quick fastener, push its pin so that it protrudes from the fastener head, then insert the fastener into the part to be secured and push the pin in with a screwdriver. Make sure that the pin is flush with the fastener's head.

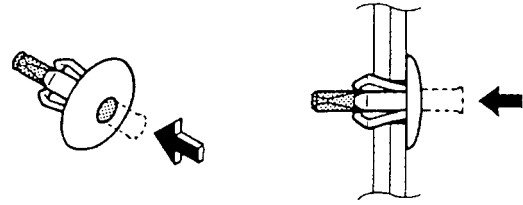
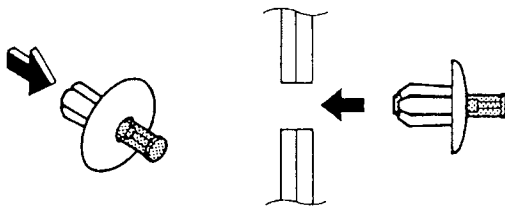

Screw type

1. Remove:
 - Quick fastener

TIP

To remove the quick fastener, loosen the screw with a screwdriver, then pull the fastener out.

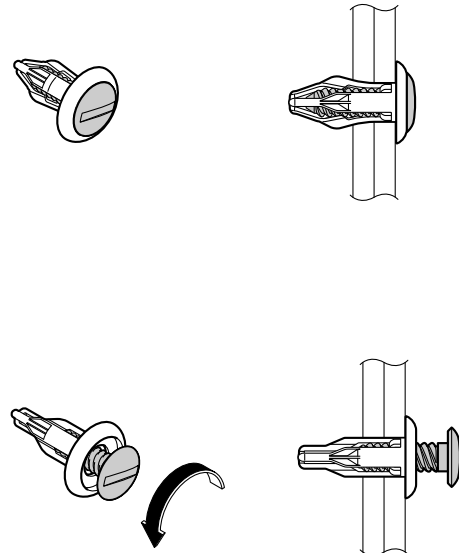

2. Install:

- Quick fastener

TIP

To install the quick fastener, insert the fastener into the part to be secured and tighten the screw.

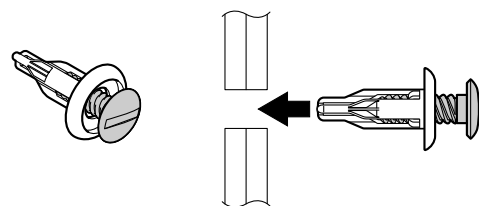

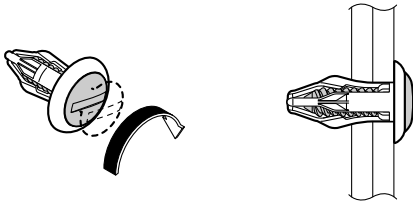

EAS30402

ELECTRICAL SYSTEM

Electrical parts handling

ECA16600

NOTICE

Never disconnect a battery lead while the engine is running; otherwise, the electrical components could be damaged.

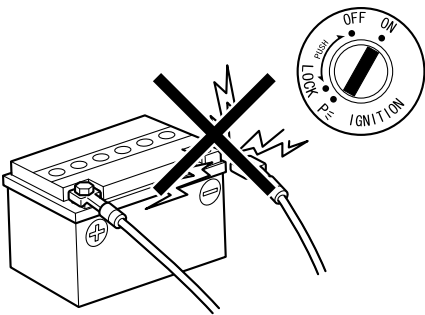

ECA16751

NOTICE

When disconnecting the battery leads from the battery, be sure to disconnect the negative battery lead first, then the positive battery lead. If the positive battery lead is disconnected first and a tool or similar item contacts the vehicle, a spark could be generated, which is extremely dangerous.

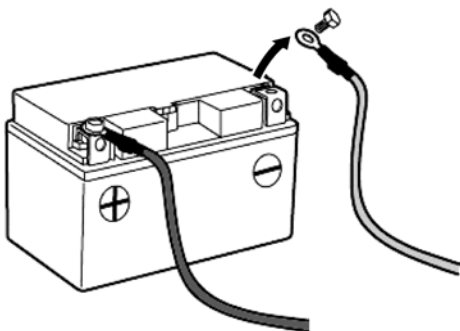

TIP

If a battery lead is difficult to disconnect due to rust on the battery terminal, remove the rust using hot water.

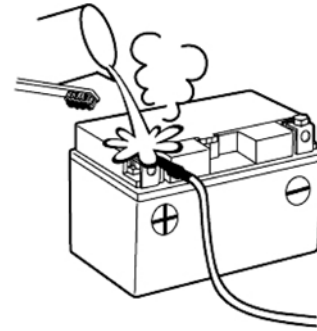

ECA16760

NOTICE

Be sure to connect the battery leads to the correct battery terminals. Reversing the battery lead connections could damage the electrical components.

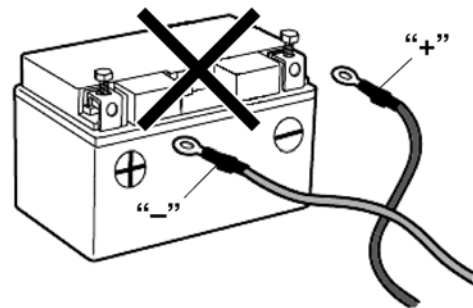

ECA16771

NOTICE

When connecting the battery leads to the battery, be sure to connect the positive battery lead first, then the negative battery lead. If the negative battery lead is connected first and a tool or similar item contacts the vehicle while the positive battery lead is being connected, a spark could be generated, which is extremely dangerous.

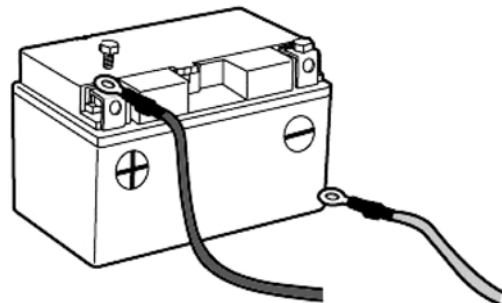

ECA16610

NOTICE

Turn the main switch to "OFF" before disconnecting or connecting an electrical component.

BASIC SERVICE INFORMATION

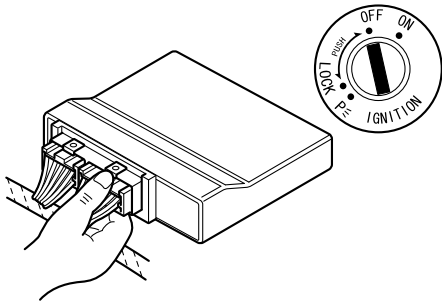

ECA16620

NOTICE

Handle electrical components with special care, and do not subject them to strong shocks.

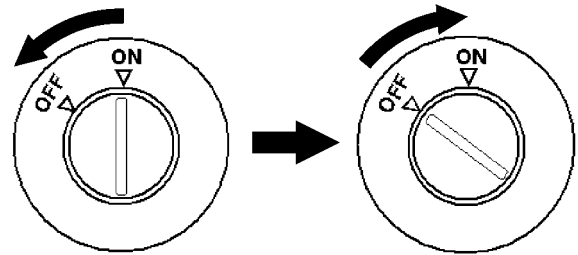

Checking the electrical system

TIP

Before checking the electrical system, make sure that the battery voltage is at least 12 V.

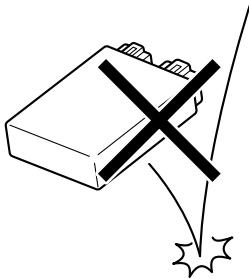

ECA16630

NOTICE

Electrical components are very sensitive to and can be damaged by static electricity. Therefore, never touch the terminals and be sure to keep the contacts clean.

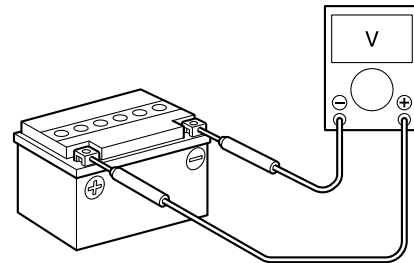

ECA14371

NOTICE

Never insert the tester probes into the coupler terminal slots. Always insert the probes from the opposite end "a" of the coupler, taking care not to loosen or damage the leads.

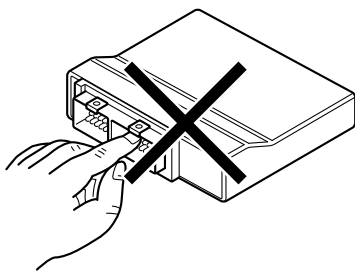

TIP

When resetting the ECU by turning the main switch to "OFF", be sure to wait approximately 5 seconds before turning the main switch back to "ON".

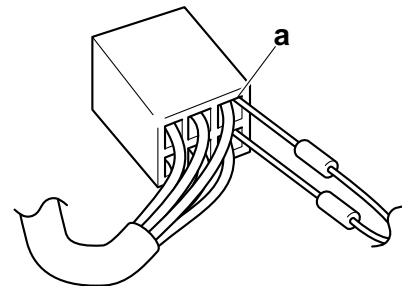

ECA16640

NOTICE

For waterproof couplers, never insert the tester probes directly into the coupler. When performing any checks using a waterproof coupler, use the specified test harness or a suitable commercially available test harness.

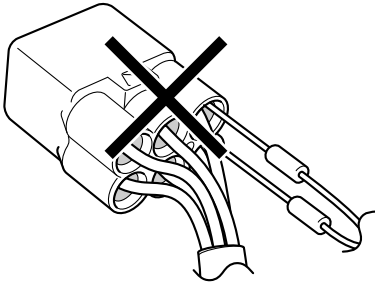

Checking the connections

Check the leads, couplers, and connectors for stains, rust, moisture, etc.

1. Disconnect:

- Lead
- Coupler
- Connector

ECA16780

NOTICE

- When disconnecting a coupler, release the coupler lock, hold both sections of the coupler securely, and then disconnect the coupler.
- There are many types of coupler locks; therefore, be sure to check the type of coupler lock before disconnecting the coupler.

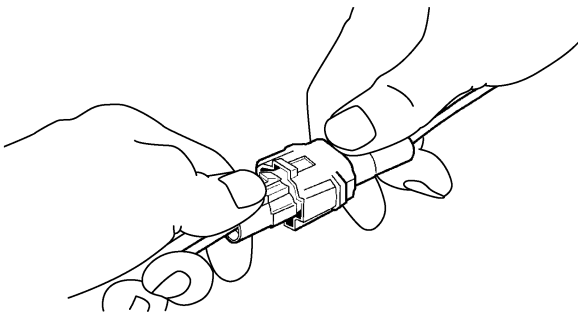

ECA16790

NOTICE

When disconnecting a connector, do not pull the leads. Hold both sections of the connector securely, and then disconnect the connector.

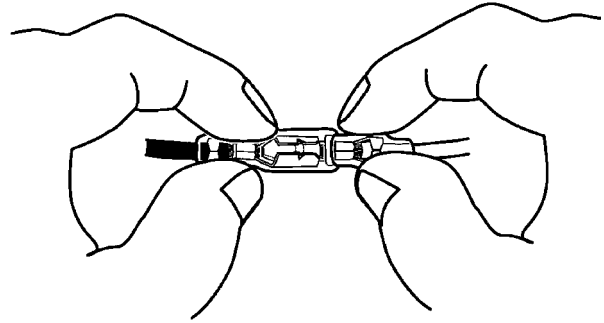

2. Check:

- Lead
- Coupler
- Connector

Moisture → Dry with an air blower.

Rust/stains → Connect and disconnect several times.

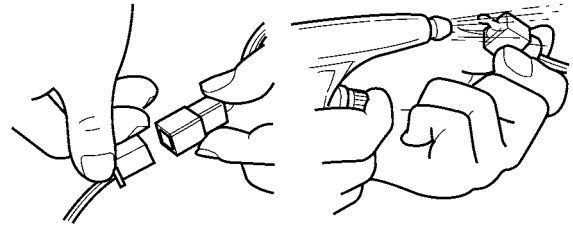

3. Connect:

- Lead
- Coupler
- Connector

TIP

- When connecting a coupler or connector, push both sections of the coupler or connector together until they are connected securely.
- Make sure all connections are tight.

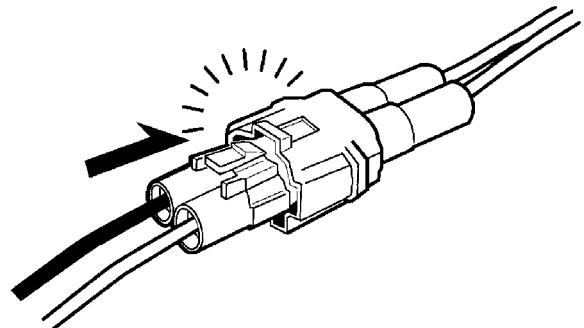

BASIC SERVICE INFORMATION

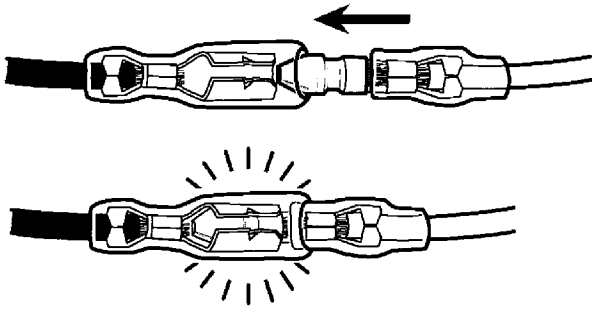

4. Check:

- Continuity
(with the pocket tester)

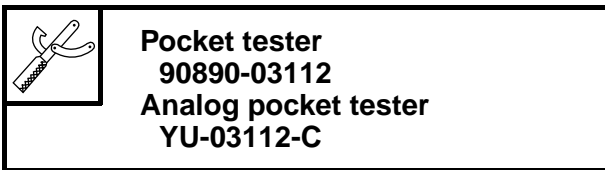

TIP

- If there is no continuity, clean the terminals.
- When checking the wire harness, perform steps (1) to (3).
- As a quick remedy, use a contact revitalizer available at most part stores.

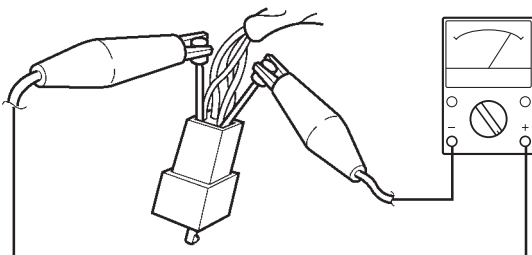
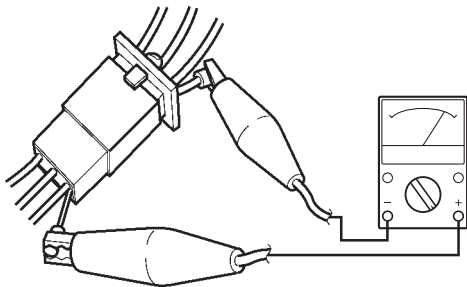

5. Check:

- Resistance

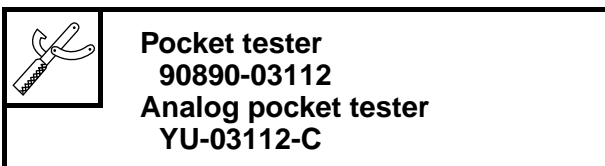

TIP

The resistance values shown were obtained at the standard measuring temperature of 20 °C (68 °F). If the measuring temperature is not 20 °C (68 °F), the specified measuring conditions will be shown.



Intake air temperature sensor resistance

5.40–6.60 k Ω at 0 °C (32 °F)
290–390 Ω at 80 °C (176 °F)

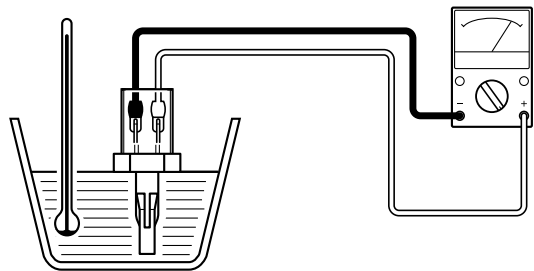

EAS20260

SPECIAL TOOLS



The following special tools are necessary for complete and accurate tune-up and assembly. Use only the appropriate special tools as this will help prevent damage caused by the use of inappropriate tools or improvised techniques. Special tools, part numbers or both may differ depending on the country. When placing an order, refer to the list provided below to avoid any mistakes.

TIP

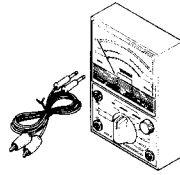
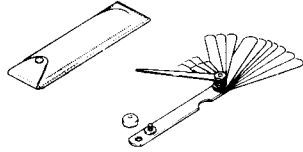
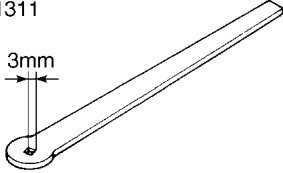
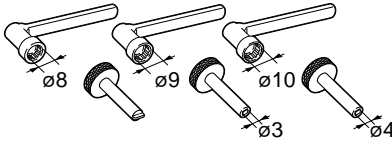
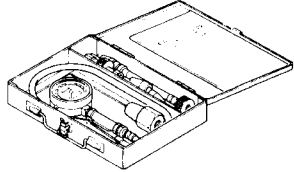
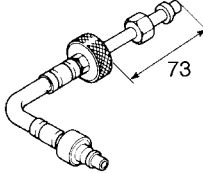
- For U.S.A. and Canada, use part numbers starting with "YM-", "YU-", or "ACC-".
- For others, use part numbers starting with "90890-".

Tool name/Tool No.	Illustration	Reference pages
Pocket tester 90890-03112 Analog pocket tester YU-03112-C		1-18, 9-81, 9-82, 9-83, 9-87, 9-89, 9-90, 9-91, 9-92, 9-93, 9-94, 9-95, 9-96, 9-97, 9-98
Thickness gauge 90890-03079 Narrow gauge set YM-34483		3-5
Tappet adjusting tool 90890-01311 Six piece tappet set YM-A5970	90890-01311  3mm YM-A5970 	3-5
Compression gauge 90890-03081 Engine compression tester YU-33223		3-8
Extension 90890-04082		3-8

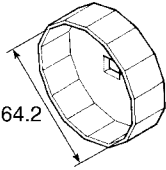

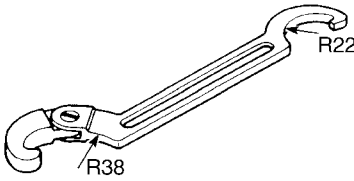
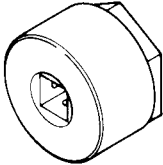
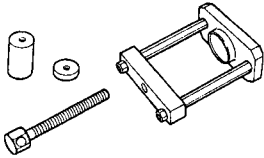
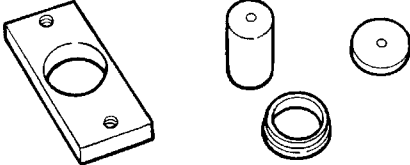
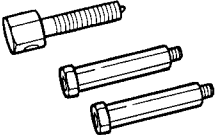
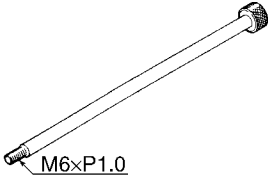
SPECIAL TOOLS

Tool name/Tool No.	Illustration	Reference pages
Oil filter wrench 90890-01426 YU-38411		3-10
Belt tension gauge 90890-03170 Rear drive belt tension gauge YM-03170		3-27
Ring nut wrench 90890-01268 Spanner wrench YU-01268		3-29, 3-30
Damper rod holder (30 mm) 90890-01327 YM-01327		4-53
Ball joint remover 90890-01474 YM-01474		4-58, 4-62
Ball joint remover attachment set 90890-01480 Ball joint adapter set YM-01480		4-58, 4-62
Ball joint remover short shaft set 90890-01514 YM-01514		4-58
Slide hammer bolt 90890-01083 Slide hammer bolt 6 mm YU-01083-1		5-18, 5-20

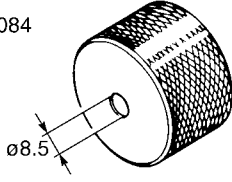
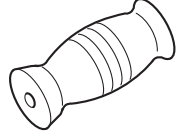
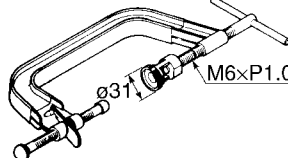
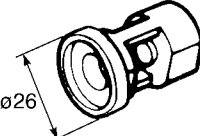
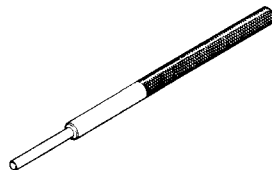
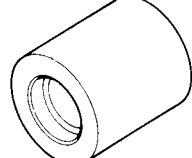
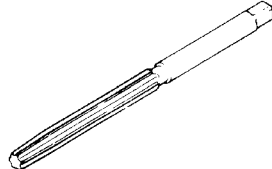
SPECIAL TOOLS

Tool name/Tool No.	Illustration	Reference pages
Weight 90890-01084 YU-01083-3	90890-01084  YU-01083-3 	5-18
Valve spring compressor 90890-04019 YM-04019		5-22, 5-27
Valve spring compressor attachment 90890-01243 Valve spring compressor adapter (26 mm) YM-01253-1		5-22, 5-27
Valve guide remover (ø6) 90890-04064 Valve guide remover (6.0 mm) YM-04064-A		5-23
Valve guide installer (ø6) 90890-04065 Valve guide installer (6.0 mm) YM-04065-A		5-23
Valve guide reamer (ø6) 90890-04066 Valve guide reamer (6.0 mm) YM-04066		5-23

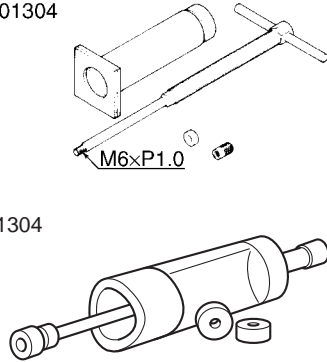
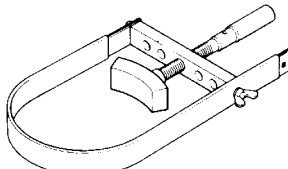
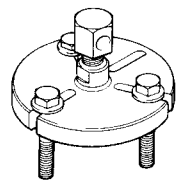
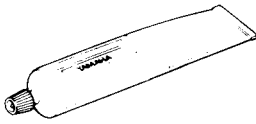
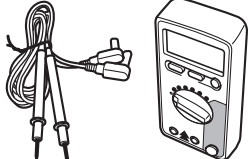
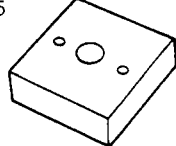
SPECIAL TOOLS

Tool name/Tool No.	Illustration	Reference pages
Piston pin puller set 90890-01304 Piston pin puller YU-01304	90890-01304  YU-01304	5-29
Sheave holder 90890-01701 Primary clutch holder YS-01880-A		5-35, 5-36, 5-37, 5-49, 5-53
Flywheel puller 90890-01362 Heavy duty puller YU-33270-B		5-35
Yamaha bond No. 1215 90890-85505 (Three Bond No.1215®)		5-37, 5-64
Digital circuit tester 90890-03174 Model 88 Multimeter with tachometer YU-A1927		5-41, 7-7
Sheave fixed block 90890-04135 Sheave fixed bracket YM-04135	90890-04135  YM-04135 	5-49, 5-52

SPECIAL TOOLS

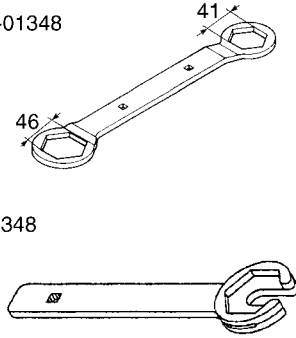
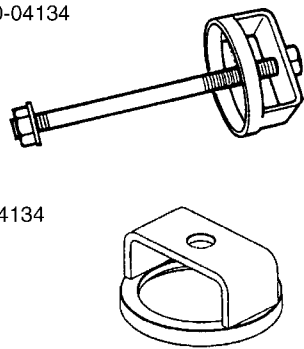
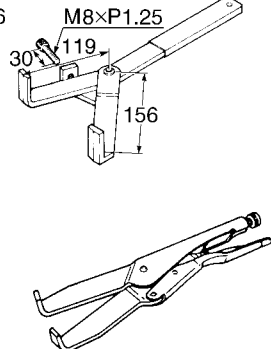
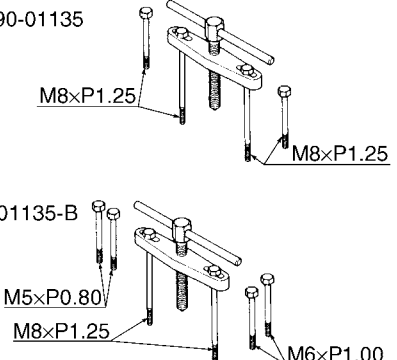
Tool name/Tool No.	Illustration	Reference pages
Locknut wrench 90890-01348 YM-01348		5-49, 5-52
Sheave spring compressor 90890-04134 YM-04134		5-49, 5-52
Universal clutch holder 90890-04086 YM-91042		5-56, 5-57
Crankcase separating tool 90890-01135 Crankcase separator YU-01135-B		5-68

SPECIAL TOOLS

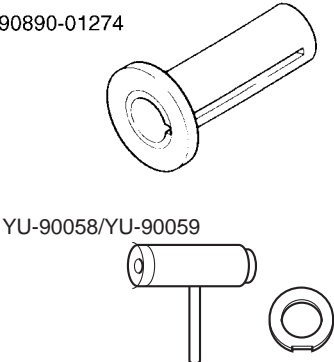
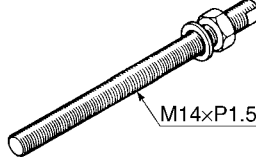
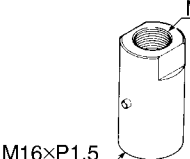
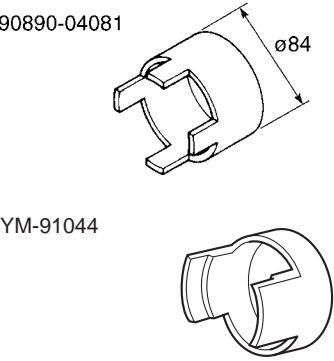
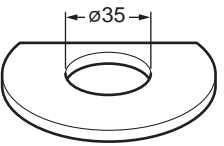
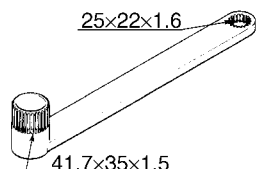
Tool name/Tool No.	Illustration	Reference pages
Crankshaft installer pot 90890-01274 Installing pot YU-90058	 <p>90890-01274</p> <p>YU-90058/YU-90059</p>	5-70
Crankshaft installer bolt 90890-01275 Bolt YU-90060	 <p>M14xP1.5</p>	5-70
Adapter (M16) 90890-04130 Adapter #13 YM-04059	 <p>M14xP1.5</p> <p>M16xP1.5</p>	5-70
Spacer (crankshaft installer) 90890-04081 Pot spacer YM-91044	 <p>90890-04081</p> <p>ø84</p> <p>YM-91044</p>	5-70
Spacer 90890-01309 Pot spacer YU-90059	 <p>ø35</p>	5-70
Coupling gear/middle shaft tool 90890-01229 Gear holder YM-01229	 <p>25x22x1.6</p> <p>41.7x35x1.5</p>	5-81, 5-84

SPECIAL TOOLS

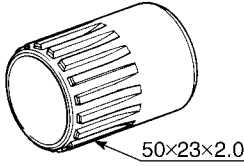
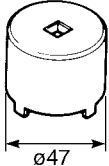
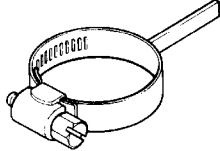
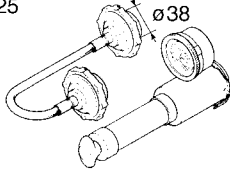
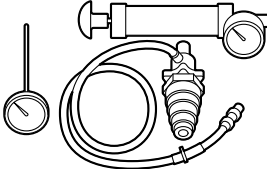
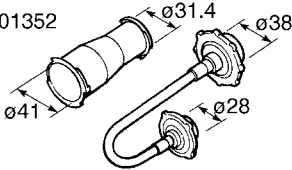
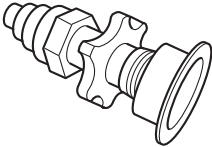
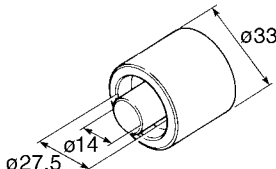
Tool name/Tool No.	Illustration	Reference pages
Bearing retainer wrench 90890-04128 Middle gear bearing retainer YM-04128		5-82, 5-83
Ring nut wrench 90890-01430 YM-38404		5-82, 5-83
Final gear backlash band 90890-01511 Middle drive gear lash tool YM-01230		5-85, 8-30
Radiator cap tester 90890-01325 Mityvac cooling system tester kit YU-24460-A	90890-01325  ø38 YU-24460-A 	6-3
Radiator cap tester adapter 90890-01352 Pressure tester adapter YU-33984	90890-01352  ø41 ø31.4 ø38 ø28 YU-33984 	6-3
Mechanical seal installer 90890-04132 Water pump seal installer YM-33221-A		6-9

SPECIAL TOOLS

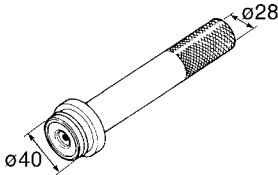
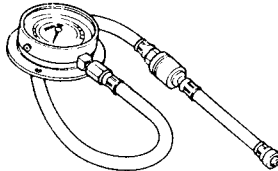
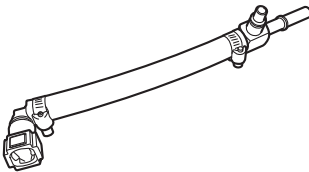
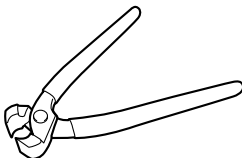
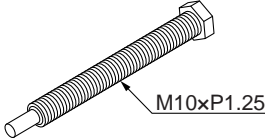
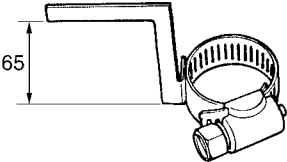
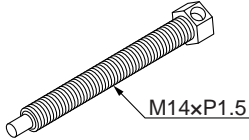
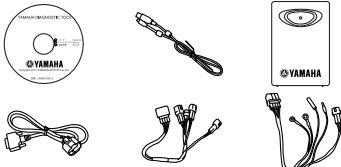
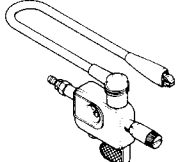
Tool name/Tool No.	Illustration	Reference pages
Middle driven shaft bearing driver 90890-04058 Middle drive bearing installer 40 & 50 mm YM-04058		6-9
Pressure gauge 90890-03153 YU-03153		7-7
Fuel pressure adapter 90890-03176 YM-03176		7-7
Boots band installation tool 90890-01526 YM-01526		8-9, 8-11, 8-22, 8-24
Ring gear fix bolt (M10) 90890-01527 YM-01527		8-13
Gear lash measurement tool 90890-01475 Middle drive gear lash tool YM-01475		8-13
Ring gear fix bolt (M14) 90890-01524 YM-01524		8-29
Yamaha diagnostic tool 90890-03215		9-38
Ignition checker 90890-06754 Oppama pet-4000 spark checker YM-34487		9-91

SPECIFICATIONS

GENERAL SPECIFICATIONS	2-1
ENGINE SPECIFICATIONS	2-2
CHASSIS SPECIFICATIONS	2-9
ELECTRICAL SPECIFICATIONS	2-12
TIGHTENING TORQUES	2-15
GENERAL TIGHTENING TORQUE SPECIFICATIONS.....	2-15
ENGINE TIGHTENING TORQUES.....	2-16
CHASSIS TIGHTENING TORQUES.....	2-19
LUBRICATION POINTS AND LUBRICANT TYPES	2-23
ENGINE.....	2-23
LUBRICATION SYSTEM CHART AND DIAGRAMS.....	2-25
LUBRICATION DIAGRAMS	2-25
COOLING SYSTEM DIAGRAMS	2-29
CABLE ROUTING	2-31

GENERAL SPECIFICATIONS

EAS29110

GENERAL SPECIFICATIONS

Model

Model	2ES2 (YF70GE) (for CDN) 2BG2 (YF70GPE) (for CDN) 2BG9 (YF70GPHE) (for CDN) 2BGC (YF70GPSE) (for CDN) 2BGF (YF70GPLE) (for CDN) 2ES3 (YFM700DE) (for Europe) 2BG3 (YFM700PE) (for Europe) 2BGA (YFM700PHE) (for Europe) 2BGD (YFM700PSE) (for Europe) 2BGG (YFM700PLE) (for Europe) 2BG4 (YFM700PE) (for Oceania) 2BGE (YFM700PSE) (for Oceania) 2BGH (YFM700PLE) (for Oceania)
-------	--

Dimensions

Overall length	2065 mm (81.3 in)
Overall width	1180 mm (46.5 in)
Overall height	1240 mm (48.8 in)
Seat height	905 mm (35.6 in)
Wheelbase	1250 mm (49.2 in)
Ground clearance	275 mm (10.8 in)
Minimum turning radius	3200 mm (126 in)

Weight

Curb weight	294.0 kg (648 lb)
Maximum loading limit	220.0 kg (485 lb) (Total weight of rider, cargo, accessories, and tongue)

ENGINE SPECIFICATIONS

EAS29120

ENGINE SPECIFICATIONS

Engine

Engine type	Liquid cooled 4-stroke, SOHC
Displacement	686.0 cm ³
Cylinder arrangement	Single cylinder
Bore × stroke	102.0 × 84.0 mm (4.02 × 3.31 in)
Compression ratio	10.00 : 1
Standard compression pressure (at sea level)	500 kPa (5.0 kgf/cm ² , 71.1 psi)
Minimum-maximum	440–560 kPa (4.4–5.6 kgf/cm ² , 62.6–79.6 psi)
Starting system	Electric starter

Fuel

Recommended fuel	Regular unleaded gasoline only (for CDN and Europe) Unleaded gasoline only (for Oceania)
Fuel tank capacity	20.0 L (5.28 US gal, 4.40 Imp.gal)
Fuel reserve amount	4.5 L (1.19 US gal, 0.99 Imp.gal)

Engine oil

Lubrication system	Wet sump
Recommended brand	YAMALUBE
Type	SAE 5W-30, 10W-30, 10W-40, 15W-40, 20W-40 or 20W-50
Recommended engine oil grade	API service SG type or higher, JASO standard MA
Engine oil quantity	
Quantity (disassembled)	2.40 L (2.54 US qt, 2.11 Imp.qt)
Without oil filter cartridge replacement	2.00 L (2.11 US qt, 1.76 Imp.qt)
With oil filter cartridge replacement	2.10 L (2.22 US qt, 1.85 Imp.qt)
Oil pressure (hot)	50.0 kPa/1600 r/min (0.50 kgf/cm ² /1600 r/min, 7.3 psi/1600 r/min)

Final gear oil

Type	SAE 80 API GL-4 Hypoid gear oil
Quantity (disassembled)	0.25 L (0.26 US qt, 0.22 Imp.qt)
Quantity	0.20 L (0.21 US qt, 0.18 Imp.qt)

Differential gear oil

Type	SAE 80 API GL-4 Hypoid gear oil
Quantity (disassembled)	0.23 L (0.24 US qt, 0.20 Imp.qt)
Quantity	0.22 L (0.23 US qt, 0.19 Imp.qt)

Oil filter

Oil filter type	Cartridge
-----------------	-----------

Oil pump

Oil pump type	Trochoid
Inner-rotor-to-outer-rotor-tip clearance	Less than 0.12 mm (0.0047 in)
Limit	0.20 mm (0.0079 in)
Outer-rotor-to-oil-pump-housing clearance	0.090–0.170 mm (0.0035–0.0067 in)
Limit	0.24 mm (0.0094 in)

ENGINE SPECIFICATIONS

Oil-pump-housing-to-inner-and-outer-rotor clearance	0.03–0.10 mm (0.0012–0.0039 in)
Limit	0.17 mm (0.0067 in)
Pressure check location	Cylinder head

Cooling system

Radiator capacity (including all routes)	1.99 L (2.10 US qt, 1.75 Imp.qt)
Coolant reservoir capacity (up to the maximum level mark)	0.24 L (0.25 US qt, 0.21 Imp.qt)
From low to full level	0.14 L (0.15 US qt, 0.12 Imp.qt)
Radiator cap opening pressure	93.3–122.7 kPa (0.95–1.25 kgf/cm ² , 13.5–17.8 psi)
Valve relief pressure	4.9 kPa (0.05 kgf/cm ² , 0.7 psi)
Thermostat	
Valve opening temperature	69–73 °C (156–163 °F)
Valve full open temperature	85 °C (185 °F)
Valve lift (full open)	8.0 mm (0.31 in)
Radiator core	
Width	408.0 mm (16.06 in)
Height	258.0 mm (10.16 in)
Depth	39.3 mm (1.55 in)
Water pump	
Water pump type	Single suction centrifugal pump
Reduction ratio	32/31 (1.032)
Impeller shaft tilt limit	0.15 mm (0.006 in)

Spark plug

Manufacturer/model	NGK/CPR7EA-9
Spark plug gap	0.8–0.9 mm (0.031–0.035 in)

Cylinder head

Combustion chamber volume	57.60–61.20 cm ³ (3.51–3.73 cu.in)
Warpage limit	0.03 mm (0.0012 in)

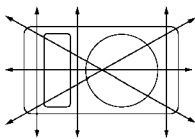

Camshaft

Drive system	Chain drive (left)
Camshaft lobe dimensions	
Intake A	42.985–43.085 mm (1.6923–1.6963 in)
Limit	42.885 mm (1.6884 in)
Intake B	36.950–37.050 mm (1.4547–1.4587 in)
Limit	36.850 mm (1.4508 in)
Exhaust A	43.490–43.590 mm (1.7122–1.7161 in)
Limit	43.390 mm (1.7083 in)
Exhaust B	36.950–37.050 mm (1.4547–1.4587 in)

ENGINE SPECIFICATIONS

Limit

36.850 mm (1.4508 in)

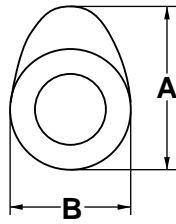

Camshaft runout limit

0.015 mm (0.0006 in)

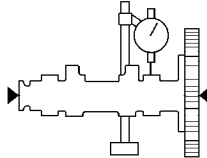

Timing chain

Tensioning system

Automatic

Rocker arm/rocker arm shaft

Rocker arm inside diameter

12.000–12.018 mm (0.4724–0.4731 in)

Rocker arm shaft outside diameter

11.981–11.991 mm (0.4717–0.4721 in)

Rocker-arm-to-rocker-arm-shaft clearance

0.009–0.037 mm (0.0004–0.0015 in)

Valve, valve seat, valve guide

Valve clearance (cold)

Intake

0.09–0.13 mm (0.0035–0.0051 in)

Exhaust

0.16–0.20 mm (0.0063–0.0079 in)

Valve dimensions

Valve head diameter A (intake)

37.90–38.10 mm (1.4921–1.5000 in)

Valve head diameter A (exhaust)

31.90–32.10 mm (1.2559–1.2638 in)

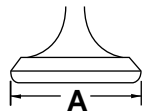

Valve face width B (intake)

2.26 mm (0.0890 in)

Valve face width B (exhaust)

2.26 mm (0.0890 in)

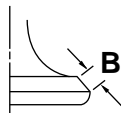

Valve seat width C (intake)

1.00–1.20 mm (0.0394–0.0472 in)

Limit

1.60 mm (0.0630 in)

Valve seat width C (exhaust)

1.00–1.20 mm (0.0394–0.0472 in)

Limit

1.60 mm (0.0630 in)

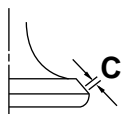

Valve margin thickness D (intake)

0.80–1.20 mm (0.0315–0.0472 in)

Limit

0.4 mm (0.02 in)

ENGINE SPECIFICATIONS

Valve margin thickness D (exhaust)
Limit

0.80–1.20 mm (0.0315–0.0472 in)
0.4 mm (0.02 in)

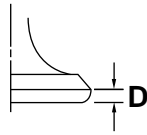

Valve stem diameter (intake)
Limit

5.975–5.990 mm (0.2352–0.2358 in)
5.945 mm (0.2341 in)

Valve stem diameter (exhaust)
Limit

5.960–5.975 mm (0.2346–0.2352 in)
5.930 mm (0.2335 in)

Valve guide inside diameter (intake)
Limit

6.000–6.012 mm (0.2362–0.2367 in)
6.050 mm (0.2382 in)

Valve guide inside diameter (exhaust)
Limit

6.000–6.012 mm (0.2362–0.2367 in)
6.050 mm (0.2382 in)

Valve-stem-to-valve-guide clearance (intake)
Limit

0.010–0.037 mm (0.0004–0.0015 in)
0.080 mm (0.0031 in)

Valve-stem-to-valve-guide clearance (exhaust)
Limit

0.025–0.052 mm (0.0010–0.0020 in)
0.100 mm (0.0039 in)

Valve stem runout

0.040 mm (0.0016 in)

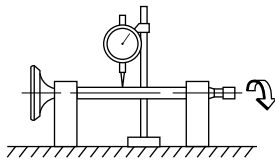

Cylinder head valve seat width (intake)
Cylinder head valve seat width (exhaust)

1.00–1.20 mm (0.0394–0.0472 in)
1.00–1.20 mm (0.0394–0.0472 in)

Valve spring

Free length (intake)
Limit

40.38 mm (1.59 in)
38.36 mm (1.51 in)

Free length (exhaust)
Limit

40.38 mm (1.59 in)
38.36 mm (1.51 in)

Installed length (intake)
Installed length (exhaust)

35.00 mm (1.38 in)
35.00 mm (1.38 in)

Spring rate K1 (intake)

34.18 N/mm (3.49 kgf/mm, 195.16 lbf/in)

Spring rate K2 (intake)

44.14 N/mm (4.50 kgf/mm, 252.04 lbf/in)

Spring rate K1 (exhaust)

34.18 N/mm (3.49 kgf/mm, 195.16 lbf/in)

Spring rate K2 (exhaust)

44.14 N/mm (4.50 kgf/mm, 252.04 lbf/in)

Installed compression spring force (intake)

171.00–197.00 N (17.44–20.09 kgf, 38.44–44.29 lbf)

Installed compression spring force (exhaust)

171.00–197.00 N (17.44–20.09 kgf, 38.44–44.29 lbf)

Spring tilt (intake)

2.5°/1.80 mm (2.5°/0.07 in)

Spring tilt (exhaust)

2.5°/1.80 mm (2.5°/0.07 in)

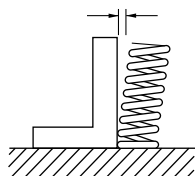

ENGINE SPECIFICATIONS

Winding direction (intake)	Clockwise
Winding direction (exhaust)	Clockwise

Cylinder

Bore	102.000–102.010 mm (4.0157–4.0161 in)
Wear limit	102.080 mm (4.0189 in)
Taper limit	0.05 mm (0.002 in)
Out of round limit	0.05 mm (0.002 in)

Piston

Piston-to-cylinder clearance	0.030–0.055 mm (0.0012–0.0022 in)
Limit	0.13 mm (0.0051 in)
Diameter D	101.955–101.970 mm (4.0140–4.0146 in)
Height H	10.0 mm (0.39 in)

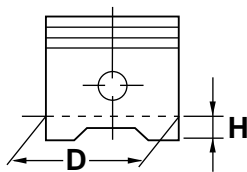

Offset	0.50 mm (0.0197 in)
Offset direction	Intake side
Piston pin bore inside diameter	23.004–23.015 mm (0.9057–0.9061 in)
Limit	23.045 mm (0.9073 in)
Piston pin outside diameter	22.991–23.000 mm (0.9052–0.9055 in)
Limit	22.971 mm (0.9044 in)
Piston-pin-to-piston-pin-bore clearance	0.004–0.024 mm (0.0002–0.0009 in)
Limit	0.0740 mm (0.0029 in)

Piston ring

Top ring	
Ring type	Barrel
Dimensions (B × T)	1.20 × 3.80 mm (0.05 × 0.15 in)

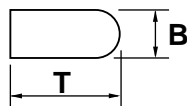

End gap (installed)	0.20–0.35 mm (0.008–0.014 in)
Limit	0.60 mm (0.024 in)
Ring side clearance	0.030–0.070 mm (0.0012–0.0028 in)
Limit	0.12 mm (0.0047 in)

2nd ring	
Ring type	Taper
Dimensions (B × T)	1.20 × 4.00 mm (0.05 × 0.16 in)

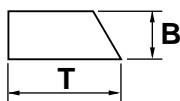

End gap (installed)	0.75–0.90 mm (0.03–0.04 in)
Limit	1.25 mm (0.049 in)
Ring side clearance	0.030–0.070 mm (0.0012–0.0028 in)

ENGINE SPECIFICATIONS

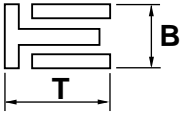
Limit	0.13 mm (0.0051 in)
Oil ring	
Dimensions (B × T)	2.50 × 2.80 mm (0.10 × 0.11 in)
	
End gap (installed)	0.20–0.70 mm (0.01–0.03 in)
Ring side clearance	0.060–0.150 mm (0.0024–0.0059 in)

Crankshaft

Width A	74.92–75.00 mm (2.950–2.953 in)
Runout limit C	0.030 mm (0.0012 in)
Big end side clearance D	0.350–0.650 mm (0.0138–0.0256 in)

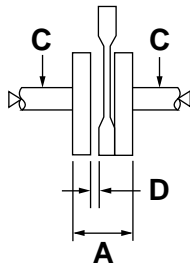

Balancer

Balancer drive method	Gear
-----------------------	------

Automatic centrifugal clutch

Clutch type	Wet, centrifugal automatic
Clutch shoe thickness	1.5 mm (0.06 in)
Limit	1.0 mm (0.04 in)
Clutch-in revolution	1950–2050 r/min
Clutch-stall revolution	3550–3650 r/min

V-belt

V-belt width	31.8–32.4 mm (1.25–1.28 in)
Limit	31.3 mm (1.23 in)

Transmission

Transmission type	V-belt automatic
Primary reduction system	V-belt
Secondary reduction system	Shaft drive
Secondary reduction ratio	41/21 × 24/18 × 33/9 (9.544)
Operation	Left hand operation
Single speed automatic	2.380–0.700 :1
Low range	31/16 (1.938)
High range	31/27 (1.148)
Reverse gear	23/14 × 28/23 (2.000)
Drive axle runout limit	0.06 mm (0.0024 in)

ENGINE SPECIFICATIONS

Shifting mechanism

Shift mechanism type	Shift drum and guide bar
Shift fork thickness	5.76–5.89 mm (0.227–0.232 in)

Decompression device

Device type	Auto decomp
-------------	-------------

Air filter

Air filter element	Wet element
Air filter oil grade	Foam air filter oil

Fuel pump

Pump type	Electrical
-----------	------------

Throttle body

Type/quantity	44EIS/1
ID mark	2BG1 00
Throttle valve size	#50

Throttle position sensor

Resistance	2.64–6.16 k Ω
Output voltage	0.63–0.73 V

Fuel injector

Model/quantity	297510–1010/1
----------------	---------------

Idling condition

Engine idling speed	1550–1650 r/min
Intake vacuum	26.0 kPa (195 mmHg, 7.7 inHg)
Water temperature	80 °C (176 °F)
Oil temperature	55–65 °C (131–149 °F)
Throttle lever free play	3.0–5.0 mm (0.12–0.20 in)
Speed limiter length	Less than 12 mm (0.47 in)

Shaft drive

Middle gear backlash	0.10–0.30 mm (0.004–0.012 in)
Final gear backlash	0.10–0.20 mm (0.004–0.008 in)
Differential gear backlash	0.05–0.25 mm (0.002–0.010 in)

CHASSIS SPECIFICATIONS

EAS29130

CHASSIS SPECIFICATIONS

Chassis

Frame type	Steel tube frame
Caster angle	4.5°
Camber angle	0.3°
Kingpin angle	11.3°
Kingpin offset	0.0 mm (0.00 in)
Trail	26.0 mm (1.02 in)
Tread rear (STD)	975.0 mm (38.39 in)
Tread front (STD)	1000.0 mm (39.37 in)
Toe-in (with tire touching the ground)	0.0–10.0 mm (0.00–0.39 in)

Front wheel

Wheel type	Panel wheel
Rim size	12 × 6.0AT
Wheel material	Steel (for models equipped with steel wheels) Aluminum (for models equipped with aluminum wheels)
Radial wheel runout limit	2.0 mm (0.08 in)
Lateral wheel runout limit	2.0 mm (0.08 in)

Rear wheel

Wheel type	Panel wheel
Rim size	12 × 7.5AT
Wheel material	Steel (for models equipped with steel wheels) Aluminum (for models equipped with aluminum wheels)
Radial wheel runout limit	2.0 mm (0.08 in)
Lateral wheel runout limit	2.0 mm (0.08 in)

Front tire

Type	Tubeless
Size	AT25 × 8–12
Manufacturer/model	MAXXIS/MU19A (for CDN and Europe) CHENG SHIN/C828 (for Oceania)
Wear limit (front)	3.0 mm (0.12 in)

Rear tire

Type	Tubeless
Size	AT25 × 10–12
Manufacturer/model	MAXXIS/MU20A (for CDN and Europe) CHENG SHIN/C828 (for Oceania)
Wear limit (rear)	3.0 mm (0.12 in)

Tire air pressure (measured on cold tires)

Recommended	
Front	35 kPa (0.35 kgf/cm ² , 5.0 psi)
Rear	30 kPa (0.30 kgf/cm ² , 4.4 psi)
Minimum	
Front	32 kPa (0.32 kgf/cm ² , 4.6 psi)
Rear	27 kPa (0.27 kgf/cm ² , 4.0 psi)

CHASSIS SPECIFICATIONS

Front brake

Type	Dual disc brake
Operation	Right hand operation
Front brake lever free play (lever end)	0 mm (0 in)
Front disc brake	
Disc outside diameter × thickness	220.0 × 3.5 mm (8.66 × 0.14 in)
Brake disc thickness limit	3.0 mm (0.12 in)
Brake disc deflection limit	0.1 mm (0.004 in)
Brake pad lining thickness (inner)	4.4 mm (0.17 in)
Limit	1.0 mm (0.04 in)
Brake pad lining thickness (outer)	4.4 mm (0.17 in)
Limit	1.0 mm (0.04 in)
Master cylinder inside diameter	12.70 mm (0.50 in)
Caliper cylinder inside diameter	33.96 mm (1.34 in)
Specified brake fluid	DOT 4

Rear brake

Type	Dual disc brake
Operation	Left hand and right foot operation
Rear brake lever free play (lever end)	0 mm (0 in)
Brake pedal free play	1.0–6.0 mm (0.04–0.24 in)
Rear disc brake	
Disc outside diameter × thickness	205.0 × 3.5 mm (8.07 × 0.14 in)
Brake disc thickness limit	3.0 mm (0.12 in)
Brake disc deflection limit	0.1 mm (0.004 in)
Brake pad lining thickness (inner)	5.8 mm (0.23 in)
Limit	1.0 mm (0.04 in)
Brake pad lining thickness (outer)	5.8 mm (0.23 in)
Limit	1.0 mm (0.04 in)
Master cylinder inside diameter	12.70 mm (0.50 in)
Caliper cylinder inside diameter	33.96 mm (1.34 in)
Specified brake fluid	DOT 4

Steering

Steering bearing type	Ball bearing
Steering tension	50 N (5.0 kgf) (for EPS models)

Front suspension

Type	Double wishbone
Spring/shock absorber type	Coil spring/oil damper
Wheel travel	193 mm (7.6 in)
Shock absorber travel	110.5 mm (4.35 in)
Spring free length	282.6 mm (11.13 in)
Installed length	258.6 mm (10.18 in)
Spring rate K1	20.50 N/mm (2.09 kgf/mm, 117.06 lbf/in)
Spring rate K2	28.90 N/mm (2.95 kgf/mm, 165.02 lbf/in)
Spring stroke K1	0.0–57.0 mm (0.00–2.24 in)
Spring stroke K2	57.0–110.5 mm (2.24–4.35 in)
Optional spring available	No
Spring preload adjusting positions	
Minimum	1
Standard	2

CHASSIS SPECIFICATIONS

Maximum	5
---------	---

Rear suspension

Type	Double wishbone
Spring/shock absorber type	Coil spring/oil damper
Wheel travel	232 mm (9.1 in)
Rear shock absorber assembly travel	119.1 mm (4.69 in)
Spring free length	304.4 mm (11.98 in)
Installed length	283.4 mm (11.16 in)
Spring rate K1	29.20 N/mm (2.98 kgf/mm, 166.73 lbf/in)
Spring rate K2	43.90 N/mm (4.48 kgf/mm, 250.67 lbf/in)
Spring stroke K1	0.0–64.0 mm (0.00–2.52 in)
Spring stroke K2	64.0–119.1 mm (2.52–4.69 in)
Optional spring available	No
Spring preload adjusting positions	
Minimum	1
Standard	2
Maximum	5

ELECTRICAL SPECIFICATIONS

EAS29140

ELECTRICAL SPECIFICATIONS

Voltage

System voltage 12 V

Ignition system

Ignition system TCI (digital)
Advancer type Digital
Ignition timing (B.T.D.C.) 5.0°/1600 r/min

Engine control unit

Model/manufacture F8T85574/MITSUBISHI

Fuel injection sensor

Crankshaft position sensor resistance 459–561 Ω
Intake air pressure sensor output voltage 3.75–4.25 V
Intake air temperature sensor resistance 290–390 Ω at 80 °C (176 °F)
Coolant temperature sensor resistance 2.32–2.59 k Ω at 20 °C (68 °F)
310–326 Ω at 80 °C (176 °F)

Ignition coil

Minimum ignition spark gap 6.0 mm (0.24 in)
Primary coil resistance 2.16–2.64 Ω
Secondary coil resistance 8.64–12.96 k Ω

Spark plug cap

Material Resin
Resistance 10.0 k Ω

AC magneto

Standard output 14.0 V 33.0 A at 5000 r/min
Stator coil resistance 0.117–0.143 Ω

Rectifier/regulator

Regulator type Semi conductor-short circuit
Regulated voltage (DC) 14.2–14.8 V
Rectifier capacity (DC) 50.0 A
Withstand voltage 40.0 V

Battery

Model YTX20L-BS
Voltage, capacity 12 V, 18.0 Ah
Manufacturer GS YUASA
Ten hour rate charging current 1.8 A

Headlight

Bulb type Halogen bulb

Bulb voltage, wattage \times quantity

Headlight 12 V, 35.0/35.0 W \times 2
Tail/brake light 12 V, 5.0/21.0 W \times 1
Meter lighting EL (Electroluminescent)

ELECTRICAL SPECIFICATIONS

Indicator and warning lights

Neutral indicator light	LED
Reverse indicator light	LED
Coolant temperature warning light	LED
Park indicator light	LED
On-Command four-wheel-drive/differential gear lock indicator	LCD
Engine trouble warning light	LED
High-range indicator light	LED
Low-range indicator light	LED
Differential gear lock indicator light	LED
EPS warning light	LED (for EPS models)

Electric starting system

System type	Constant mesh
-------------	---------------

Starter motor

Power output	0.80 kW
Armature coil resistance	0.0050–0.0150 Ω
Brush overall length	12.0 mm (0.47 in)
Limit	6.50 mm (0.26 in)
Brush spring force	6.02–6.51 N (614–664 gf, 21.69–23.45 oz)
Mica undercut (depth)	0.70 mm (0.03 in)

Starter relay

Amperage	180.0 A
Coil resistance	4.18–4.62 Ω

Horn (for Europe and Oceania)

Horn type	Plane
Quantity	1 pc
Maximum amperage	1.0 A

Fuel sender unit

Sender unit resistance (full)	19.00–21.00 Ω
Sender unit resistance (empty)	139.00–141.00 Ω

Auxiliary DC output

Jack capacity	12 V, 10.0 A (120 W)
---------------	----------------------

Fan motor relay

Coil resistance	86.4–105.6 Ω
-----------------	---------------------

Fuel injection system relay

Coil resistance	86.4–105.6 Ω
-----------------	---------------------

Headlight relay

Coil resistance	94.5–115.5 Ω
-----------------	---------------------

Four-wheel-drive motor relay 1, 2

Coil resistance	94.5–115.5 Ω
-----------------	---------------------

ELECTRICAL SPECIFICATIONS

Circuit breaker

Circuit breaker type

Fuse

Fuses

Main fuse	40.0 A
Headlight fuse	10.0 A
Signaling system fuse	5.0 A
Ignition fuse	10.0 A
Radiator fan motor fuse	20.0 A
Auxiliary DC jack fuse	10.0 A
Fuel injection system fuse	15.0 A
Four-wheel-drive motor fuse	10.0 A
EPS fuse	40.0 A (for EPS models)
Spare fuse	20.0 A
Spare fuse	15.0 A
Spare fuse	10.0 A
Spare fuse	5.0 A

EAS20320

TIGHTENING TORQUES

EAS20330

GENERAL TIGHTENING TORQUE SPECIFICATIONS

This chart specifies tightening torques for standard fasteners with a standard ISO thread pitch. Tightening torque specifications for special components or assemblies are provided for each chapter of this manual. To avoid warpage, tighten multi-fastener assemblies in a crisscross pattern and progressive stages until the specified tightening torque is reached. Unless otherwise specified, tightening torque specifications require clean, dry threads. Components should be at room temperature.

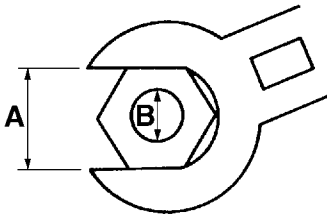







- A. Distance between flats
- B. Outside thread diameter

A (nut)	B (bolt)	General tightening torques		
		Nm	m·kg	ft·lb
10 mm	6 mm	6	0.6	4.3
12 mm	8 mm	15	1.5	11
14 mm	10 mm	30	3.0	22
17 mm	12 mm	55	5.5	40
19 mm	14 mm	85	8.5	61
22 mm	16 mm	130	13.0	94

TIGHTENING TORQUES

EAS20340







ENGINE TIGHTENING TORQUES

Item	Thread size	Q'ty	Tightening torque	Remarks
Exhaust pipe nut	M8	2	20 Nm (2.0 m·kg, 14 ft·lb)	
Muffler bolt	M8	1	33 Nm (3.3 m·kg, 24 ft·lb)	
Muffler bracket bolt	M8	2	20 Nm (2.0 m·kg, 14 ft·lb)	
Spark arrester bolt	M6	4	10 Nm (1.0 m·kg, 7.2 ft·lb)	
Exhaust pipe protector bolt	M6	2	7 Nm (0.7 m·kg, 5.1 ft·lb)	
Crankshaft end accessing screw	M36	1	2 Nm (0.2 m·kg, 1.4 ft·lb)	
Timing mark accessing screw	M14	1	1.5 Nm (0.15 m·kg, 1.1 ft·lb)	
AC magneto cover bolt	M6	11	10 Nm (1.0 m·kg, 7.2 ft·lb)	
AC magneto rotor nut	M16	1	60 Nm (6.0 m·kg, 43 ft·lb)	
AC magneto/crankshaft position sensor lead holder bolt	M5	2	7 Nm (0.7 m·kg, 5.1 ft·lb)	
Starter clutch bolt	M8	3	30 Nm (3.0 m·kg, 22 ft·lb)	
Drive belt cover bolt	M6	12	10 Nm (1.0 m·kg, 7.2 ft·lb)	
Drive belt case bolt	M6	8	10 Nm (1.0 m·kg, 7.2 ft·lb)	
Bearing housing bolt (primary sheave assembly)	M6	4	10 Nm (1.0 m·kg, 7.2 ft·lb)	
Bearing retainer bolt (bearing housing)	M6	1	10 Nm (1.0 m·kg, 7.2 ft·lb)	
Primary sheave assembly nut	M16	1	140 Nm (14.0 m·kg, 100 ft·lb)	
Secondary sheave assembly nut	M16	1	100 Nm (10.0 m·kg, 72 ft·lb)	
Secondary sheave spring retaining nut	M36	1	90 Nm (9.0 m·kg, 65 ft·lb)	
Clutch housing assembly bolt	M6	9	10 Nm (1.0 m·kg, 7.2 ft·lb)	
Clutch carrier assembly nut	M22	1	190 Nm (19.0 m·kg, 140 ft·lb)	Left-hand thread Stake. 
Cylinder bolt	M10	4	50 Nm (5.0 m·kg, 36 ft·lb)	See TIP. 
Cylinder bolt	M6	2	10 Nm (1.0 m·kg, 7.2 ft·lb)	
Cylinder head stud bolt (exhaust pipe)	M8	2	15 Nm (1.5 m·kg, 11 ft·lb)	
Reed valve cover bolt	M6	2	10 Nm (1.0 m·kg, 7.2 ft·lb)	
Cylinder head bolt	M9	4	35 Nm (3.5 m·kg, 25 ft·lb)	
Cylinder head bolt	M9	2	38 Nm (3.8 m·kg, 27 ft·lb)	
Cylinder head bolt	M6	2	10 Nm (1.0 m·kg, 7.2 ft·lb)	
Tappet cover bolt	M6	8	10 Nm (1.0 m·kg, 7.2 ft·lb)	
Camshaft sprocket cover bolt	M6	2	10 Nm (1.0 m·kg, 7.2 ft·lb)	
Thermostat cover bolt	M6	2	10 Nm (1.0 m·kg, 7.2 ft·lb)	

TIGHTENING TORQUES

Item	Thread size	Q'ty	Tightening torque	Remarks
Oil check bolt	M8	1	10 Nm (1.0 m·kg, 7.2 ft·lb)	
Cylinder head air bleed bolt	M6	1	10 Nm (1.0 m·kg, 7.2 ft·lb)	
Camshaft sprocket bolt	M7	2	20 Nm (2.0 m·kg, 14 ft·lb)	
Decompression assembly bolt	M7	2	20 Nm (2.0 m·kg, 14 ft·lb)	
Valve adjusting screw locknut	M6	4	14 Nm (1.4 m·kg, 10 ft·lb)	
Bearing retainer bolt (camshaft)	M6	2	10 Nm (1.0 m·kg, 7.2 ft·lb)	
Timing chain guide bolt (intake side)	M6	2	10 Nm (1.0 m·kg, 7.2 ft·lb)	
Timing chain tensioner cap bolt	M16	1	20 Nm (2.0 m·kg, 14 ft·lb)	
Timing chain tensioner bolt	M6	2	10 Nm (1.0 m·kg, 7.2 ft·lb)	
Oil delivery pipe 1 union bolt	M8	2	18 Nm (1.8 m·kg, 13 ft·lb)	
Oil delivery pipe 2 union bolt	M14	2	35 Nm (3.5 m·kg, 25 ft·lb)	
Oil delivery pipe 2 union bolt	M10	1	20 Nm (2.0 m·kg, 14 ft·lb)	
Oil delivery pipe 2 bolt	M6	1	10 Nm (1.0 m·kg, 7.2 ft·lb)	
Crankcase bolt	M8	3	26 Nm (2.6 m·kg, 19 ft·lb)	
Crankcase bolt	M6	4	10 Nm (1.0 m·kg, 7.2 ft·lb)	
Crankcase bolt	M6	9	10 Nm (1.0 m·kg, 7.2 ft·lb)	
Dipstick guide bolt	M6	1	10 Nm (1.0 m·kg, 7.2 ft·lb)	
Engine oil drain bolt	M14	1	30 Nm (3.0 m·kg, 22 ft·lb)	
Oil filter cartridge	M20	1	17 Nm (1.7 m·kg, 12 ft·lb)	
Oil filter cartridge union bolt	M20	1	68 Nm (6.8 m·kg, 49 ft·lb)	
Timing chain guide bolt (lower)	M6	2	10 Nm (1.0 m·kg, 7.2 ft·lb)	
Bearing retainer bolt (crankcase)	M6	2	10 Nm (1.0 m·kg, 7.2 ft·lb)	
Oil pump bolt	M6	3	10 Nm (1.0 m·kg, 7.2 ft·lb)	
Oil pump housing cover screw	M5	1	5 Nm (0.5 m·kg, 3.6 ft·lb)	
Oil pump driven gear nut	M10	1	22 Nm (2.2 m·kg, 16 ft·lb)	Use a lock washer.
Intake air pressure sensor screw	M6	1	3.5 Nm (0.35 m·kg, 2.5 ft·lb)	
Throttle position sensor screw	M5	2	3.5 Nm (0.35 m·kg, 2.5 ft·lb)	
Fuel rail screw	M6	2	5 Nm (0.5 m·kg, 3.6 ft·lb)	
Balancer driven gear nut	M18	1	85 Nm (8.5 m·kg, 61 ft·lb)	Use a lock washer.
Water pump housing bolt	M6	3	10 Nm (1.0 m·kg, 7.2 ft·lb)	
Coolant drain bolt	M6	1	10 Nm (1.0 m·kg, 7.2 ft·lb)	
Water pump air bleed bolt	M6	1	10 Nm (1.0 m·kg, 7.2 ft·lb)	
Water pump outlet pipe bolt	M6	1	10 Nm (1.0 m·kg, 7.2 ft·lb)	
Water jacket joint bolt	M6	2	10 Nm (1.0 m·kg, 7.2 ft·lb)	
Shift lever cover bolt	M6	4	10 Nm (1.0 m·kg, 7.2 ft·lb)	

TIGHTENING TORQUES

Item	Thread size	Q'ty	Tightening torque	Remarks
Shift lever 2 assembly bolt	M6	1	14 Nm (1.4 m·kg, 10 ft·lb)	
Shift drum stopper bolt	M14	1	18 Nm (1.8 m·kg, 13 ft·lb)	
Stopper lever stopper bolt	M14	1	18 Nm (1.8 m·kg, 13 ft·lb)	
Middle drive pinion gear nut	M22	1	190 Nm (19.0 m·kg, 140 ft·lb)	Stake.
Middle drive shaft bearing housing bolt	M8	4	32 Nm (3.2 m·kg, 23 ft·lb)	
Middle drive shaft bearing retainer bolt	M8	4	29 Nm (2.9 m·kg, 21 ft·lb)	Stake. 
Front drive shaft yoke nut (middle gear side)	M16	1	115 Nm (11.5 m·kg, 85 ft·lb)	
Middle driven shaft bearing retainer	M55	1	80 Nm (8.0 m·kg, 58 ft·lb)	Left-hand thread 
Middle driven pinion gear bearing housing bolt	M8	4	25 Nm (2.5 m·kg, 18 ft·lb)	
Middle driven pinion gear bearing retainer	M60	1	130 Nm (13.0 m·kg, 94 ft·lb)	Left-hand thread 
Rear drive shaft yoke nut (middle gear side)	M16	1	150 Nm (15.0 m·kg, 110 ft·lb)	
Starter motor bolt	M6	2	10 Nm (1.0 m·kg, 7.2 ft·lb)	
Starter motor lead nut	M6	1	11 Nm (1.1 m·kg, 8.0 ft·lb)	
Spark plug	M10	1	13 Nm (1.3 m·kg, 9.4 ft·lb)	
Stator coil assembly bolt	M6	3	7 Nm (0.7 m·kg, 5.1 ft·lb)	
Crankshaft position sensor bolt	M5	2	7 Nm (0.7 m·kg, 5.1 ft·lb)	
Coolant temperature sensor	M12	1	18 Nm (1.8 m·kg, 13 ft·lb)	
Gear position switch bolt	M6	2	7 Nm (0.7 m·kg, 5.1 ft·lb)	
Reverse switch	M10	1	17 Nm (1.7 m·kg, 12 ft·lb)	
Speed sensor bolt	M6	1	10 Nm (1.0 m·kg, 7.2 ft·lb)	

TIP

Temporarily tighten the cylinder bolts to 15 Nm (1.5 m·kg, 11 ft·lb) and then tighten them to 50 Nm (5.0 m·kg, 36 ft·lb).

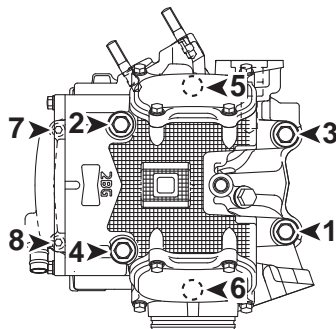

Cylinder head tightening sequence:









TIGHTENING TORQUES

EAS20350







CHASSIS TIGHTENING TORQUES

Item	Thread size	Q'ty	Tightening torque	Remarks
Engine mounting bolt (front lower side)	M10	2	42 Nm (4.2 m·kg, 30 ft·lb)	
Engine mounting bolt (front upper side)	M6	2	10 Nm (1.0 m·kg, 7.2 ft·lb)	
Engine mounting bolt (rear lower side)	M10	2	42 Nm (4.2 m·kg, 30 ft·lb)	
Engine mounting bolt (rear upper side)	M6	2	10 Nm (1.0 m·kg, 7.2 ft·lb)	
Rubber damper nut (front side)	M10	2	42 Nm (4.2 m·kg, 30 ft·lb)	
Rubber damper nut (rear side)	M10	2	42 Nm (4.2 m·kg, 30 ft·lb)	
Trailer hitch bolt	M10	2	55 Nm (5.5 m·kg, 40 ft·lb)	
Drive select lever unit bolt	M6	2	7 Nm (0.7 m·kg, 5.1 ft·lb)	
Drive select lever guide bolt	M6	1	7 Nm (0.7 m·kg, 5.1 ft·lb)	
Shift arm bolt	M6	1	14 Nm (1.4 m·kg, 10 ft·lb)	
Shift control cable nut	M14	1	17 Nm (1.7 m·kg, 12 ft·lb)	
Drive select lever shift rod locknut (select lever unit side)	M6	1	7 Nm (0.7 m·kg, 5.1 ft·lb)	Left-hand thread
Drive select lever shift rod locknut (shift arm side)	M6	1	7 Nm (0.7 m·kg, 5.1 ft·lb)	
Brake pedal free play adjusting nut	M8	1	7 Nm (0.7 m·kg, 5.1 ft·lb)	
Radiator bolt	M6	2	7 Nm (0.7 m·kg, 5.1 ft·lb)	
Radiator bracket bolt	M6	2	7 Nm (0.7 m·kg, 5.1 ft·lb)	
Coolant reservoir bolt	M6	2	7 Nm (0.7 m·kg, 5.1 ft·lb)	
Air cut-off valve bracket bolt	M6	1	10 Nm (1.0 m·kg, 7.2 ft·lb)	
Fuel tank bolt	M6	4	7 Nm (0.7 m·kg, 5.1 ft·lb)	
Fuel pump nut	M6	6	7 Nm (0.7 m·kg, 5.1 ft·lb)	
Fuel tank side cover bolt	M6	2	7 Nm (0.7 m·kg, 5.1 ft·lb)	
Fuel tank breather hose joint bolt	M6	1	7 Nm (0.7 m·kg, 5.1 ft·lb)	
Throttle body joint clamp screw	M5	2	3 Nm (0.3 m·kg, 2.2 ft·lb)	
Engine skid plate bolt	M6	8	7 Nm (0.7 m·kg, 5.1 ft·lb)	
Footrest bracket bolt	M10	4	16 Nm (1.6 m·kg, 11 ft·lb)	
Footrest board bolt	M6	8	7 Nm (0.7 m·kg, 5.1 ft·lb)	
Front carrier bolt	M8	4	34 Nm (3.4 m·kg, 24 ft·lb)	
Front carrier bolt	M6	2	7 Nm (0.7 m·kg, 5.1 ft·lb)	
Front guard bolt	M8	4	34 Nm (3.4 m·kg, 24 ft·lb)	
Front guard cover bolt	M6	2	7 Nm (0.7 m·kg, 5.1 ft·lb)	
Front grill bolt	M6	2	7 Nm (0.7 m·kg, 5.1 ft·lb)	
Front grill bracket bolt	M6	2	7 Nm (0.7 m·kg, 5.1 ft·lb)	

TIGHTENING TORQUES

Item	Thread size	Q'ty	Tightening torque	Remarks
Front fender bolt	M6	2	7 Nm (0.7 m·kg, 5.1 ft·lb)	
Rear carrier bolt	M8	2	34 Nm (3.4 m·kg, 24 ft·lb)	
Rear carrier bolt	M6	2	7 Nm (0.7 m·kg, 5.1 ft·lb)	
Rear carrier bracket bolt	M10	4	60 Nm (6.0 m·kg, 43 ft·lb)	
Rear fender bolt	M6	4	7 Nm (0.7 m·kg, 5.1 ft·lb)	
Front wheel nut	M10	8	55 Nm (5.5 m·kg, 40 ft·lb)	
Front wheel axle nut	M20	2	260 Nm (26.0 m·kg, 190 ft·lb)	Stake.
Rear wheel nut	M10	8	55 Nm (5.5 m·kg, 40 ft·lb)	
Rear wheel axle nut	M20	2	260 Nm (26.0 m·kg, 190 ft·lb)	Stake.
Front brake caliper bolt	M8	4	30 Nm (3.0 m·kg, 22 ft·lb)	
Front brake disc bolt	M8	8	30 Nm (3.0 m·kg, 22 ft·lb)	
Rear brake caliper bolt	M8	4	30 Nm (3.0 m·kg, 22 ft·lb)	
Rear brake disc bolt	M8	8	30 Nm (3.0 m·kg, 22 ft·lb)	
Brake hose union bolt	M10	6	27 Nm (2.7 m·kg, 19 ft·lb)	
Brake pad holding bolt	M6	4	17 Nm (1.7 m·kg, 12 ft·lb)	
Brake caliper bleed screw	M8	4	5 Nm (0.5 m·kg, 3.6 ft·lb)	
Steering knuckle and front upper arm nut	M12	2	30 Nm (3.0 m·kg, 22 ft·lb)	
Steering knuckle and front lower arm nut	M12	2	30 Nm (3.0 m·kg, 22 ft·lb)	
Steering knuckle and tie-rod nut	M10	2	25 Nm (2.5 m·kg, 18 ft·lb)	
Front upper arm nut	M10	4	50 Nm (5.0 m·kg, 36 ft·lb)	
Front lower arm nut	M10	4	50 Nm (5.0 m·kg, 36 ft·lb)	
Front shock absorber assembly nut	M10	4	45 Nm (4.5 m·kg, 32 ft·lb)	
Front brake disc guard bolt	M6	6	7 Nm (0.7 m·kg, 5.1 ft·lb)	
Front brake hose holder bolt	M6	4	7 Nm (0.7 m·kg, 5.1 ft·lb)	
Front arm protector bolt	M6	2	7 Nm (0.7 m·kg, 5.1 ft·lb)	
Rear knuckle nut	M10	4	45 Nm (4.5 m·kg, 32 ft·lb)	
Rear upper arm nut	M10	4	50 Nm (5.0 m·kg, 36 ft·lb)	
Rear lower arm nut	M10	4	50 Nm (5.0 m·kg, 36 ft·lb)	
Rear shock absorber assembly nut	M10	4	45 Nm (4.5 m·kg, 32 ft·lb)	
Rear brake disc guard bolt	M6	6	7 Nm (0.7 m·kg, 5.1 ft·lb)	
Rear brake hose guide bolt	M6	4	7 Nm (0.7 m·kg, 5.1 ft·lb)	
Rear arm protector bolt	M6	4	7 Nm (0.7 m·kg, 5.1 ft·lb)	
Rear arm protector nut	M6	2	7 Nm (0.7 m·kg, 5.1 ft·lb)	
Rear brake disc cleaning plate bolt	M6	4	7 Nm (0.7 m·kg, 5.1 ft·lb)	

TIGHTENING TORQUES

Item	Thread size	Q'ty	Tightening torque	Remarks
Stabilizer joint nut	M10	4	56 Nm (5.6 m·kg, 40 ft·lb)	
Stabilizer holder bolt	M8	4	30 Nm (3.0 m·kg, 22 ft·lb)	
Handlebar holder bolt	M8	4	20 Nm (2.0 m·kg, 14 ft·lb)	
Front brake master cylinder holder bolt	M6	2	7 Nm (0.7 m·kg, 5.1 ft·lb)	
Rear brake master cylinder holder bolt	M6	2	7 Nm (0.7 m·kg, 5.1 ft·lb)	
Front brake lever pivot bolt	M6	1	6 Nm (0.6 m·kg, 4.3 ft·lb)	
Front brake lever pivot nut	M6	1	6 Nm (0.6 m·kg, 4.3 ft·lb)	
Rear brake lever pivot bolt	M6	1	6 Nm (0.6 m·kg, 4.3 ft·lb)	Left-hand thread 
Rear brake lever pivot nut	M6	1	6 Nm (0.6 m·kg, 4.3 ft·lb)	Left-hand thread
Front brake hose joint bolt	M6	1	10 Nm (1.0 m·kg, 7.2 ft·lb)	
Rear brake hose joint bolt	M6	1	10 Nm (1.0 m·kg, 7.2 ft·lb)	
Brake pipe locknut	M10	3	19 Nm (1.9 m·kg, 13 ft·lb)	
Steering stem bolt	M8	2	23 Nm (2.3 m·kg, 17 ft·lb)	
Steering stem bracket bolt	M10	2	51 Nm (5.1 m·kg, 37 ft·lb)	
Steering stem support bolt (except for EPS models)	M8	4	34 Nm (3.4 m·kg, 24 ft·lb)	
Pitman arm nut (except for EPS models)	M14	1	190 Nm (19.0 m·kg, 140 ft·lb)	
Bearing retainer (steering stem)	M42	1	40 Nm (4.0 m·kg, 29 ft·lb)	
Steering stem pinch bolt (for EPS models)	M8	1	35 Nm (3.5 m·kg, 25 ft·lb)	
EPS unit bolt (for EPS models)	M8	4	30 Nm (3.0 m·kg, 22 ft·lb)	
Pitman arm nut (for EPS models)	M16	1	210 Nm (21.0 m·kg, 150 ft·lb)	
EPS motor cover bolt (for EPS models)	M6	2	7 Nm (0.7 m·kg, 5.1 ft·lb)	
Pitman arm and tie-rod nut	M10	2	25 Nm (2.5 m·kg, 18 ft·lb)	
Tie-rod end locknut (pitman arm side)	M10	2	15 Nm (1.5 m·kg, 11 ft·lb)	
Tie-rod end locknut (front wheel side)	M10	2	15 Nm (1.5 m·kg, 11 ft·lb)	Left-hand thread
Differential assembly nut	M10	1	55 Nm (5.5 m·kg, 40 ft·lb)	
Differential assembly bolt	M10	2	55 Nm (5.5 m·kg, 40 ft·lb)	
Differential gear oil filler bolt	M14	1	23 Nm (2.3 m·kg, 17 ft·lb)	
Differential gear oil drain bolt	M10	1	10 Nm (1.0 m·kg, 7.2 ft·lb)	
Differential case cover bolt	M8	5	24 Nm (2.4 m·kg, 17 ft·lb)	
Differential motor bolt	M6	3	11 Nm (1.1 m·kg, 8.0 ft·lb)	

TIGHTENING TORQUES

Item	Thread size	Q'ty	Tightening torque	Remarks
Front drive shaft yoke nut (differential case side)	M14	1	62 Nm (6.2 m·kg, 45 ft·lb)	
Final drive assembly nut	M10	2	66 Nm (6.6 m·kg, 48 ft·lb)	
Final gear oil filler bolt	M14	1	23 Nm (2.3 m·kg, 17 ft·lb)	
Final gear oil drain bolt	M14	1	23 Nm (2.3 m·kg, 17 ft·lb)	
Final gear oil level check bolt	M8	1	10 Nm (1.0 m·kg, 7.2 ft·lb)	
Final drive case cover bolt	M8	11	23 Nm (2.3 m·kg, 17 ft·lb)	
Final drive pinion gear bearing housing bolt	M8	4	23 Nm (2.3 m·kg, 17 ft·lb)	
Electrical components tray bolt	M6	3	7 Nm (0.7 m·kg, 5.1 ft·lb)	
Battery holding bracket fitting screw	M6	2	7 Nm (0.7 m·kg, 5.1 ft·lb)	
Battery holding bracket nut	M6	2	7 Nm (0.7 m·kg, 5.1 ft·lb)	
ECU (engine control unit) screw	M6	1	3 Nm (0.3 m·kg, 2.2 ft·lb)	
Rectifier/regulator bolt	M6	2	7 Nm (0.7 m·kg, 5.1 ft·lb)	
Ignition coil bolt	M6	2	7 Nm (0.7 m·kg, 5.1 ft·lb)	
Frame ground bolt	M6	1	7 Nm (0.7 m·kg, 5.1 ft·lb)	
Horn bracket bolt (for Europe and Oceania)	M6	1	7 Nm (0.7 m·kg, 5.1 ft·lb)	
License plate bracket nut (for CDN)	M6	2	7 Nm (0.7 m·kg, 5.1 ft·lb)	

































LUBRICATION POINTS AND LUBRICANT TYPES

EAS20360











LUBRICATION POINTS AND LUBRICANT TYPES

EAS20370

ENGINE

Lubrication point	Lubricant
Oil seal lips	
Bearings	
O-rings	
Cylinder head bolts	
Crankshaft pin	
Connecting rod big end thrust surface	
Crankshaft sprocket	
Inner race (crankshaft)	
Buffer boss (crankshaft)	
Crankshaft seal	
Piston pin	
Piston rings and ring grooves	
Valve stems (intake and exhaust)	
Valve stem seal (intake and exhaust)	
Rocker arm shafts	
Camshaft lobes	
Decompressor lever pin	
Decompressor lever	
Rocker arms (intake and exhaust)	
Oil pump shaft	
O-ring (oil filter cartridge)	
Water pump impeller shaft	
Dipstick mating surface	
Starter idler gear inner surface	
Starter idler gear shaft	
Starter wheel gear	
Torque limiter	
Clutch housing shaft end	
Clutch carrier assembly	
One-way clutch bearing	
Clutch dog and middle drive gear	
Reverse idle gear	
Reverse idle gear shaft	

LUBRICATION POINTS AND LUBRICANT TYPES

Lubrication point	Lubricant
Middle driven shaft splines	
Shift drum	
Shift forks and shift fork guide bar	
Ball (shift drum stopper)	
Stopper lever and stopper lever shaft	
Shift lever 2 inner surface	
Shift lever 1	
Shift lever 1 gear teeth and shift lever 2 gear teeth	
Stopper lever stopper	
Bearing (final drive pinion gear)	
Bearing (final drive case)	
AC magneto lead grommet	Yamaha bond No.1215 (Three bond No.1215®)
Crankcase mating surface	Yamaha bond No.1215 (Three bond No.1215®)

LUBRICATION SYSTEM CHART AND DIAGRAMS

EAS20390

LUBRICATION SYSTEM CHART AND DIAGRAMS

EAS20410

LUBRICATION DIAGRAMS

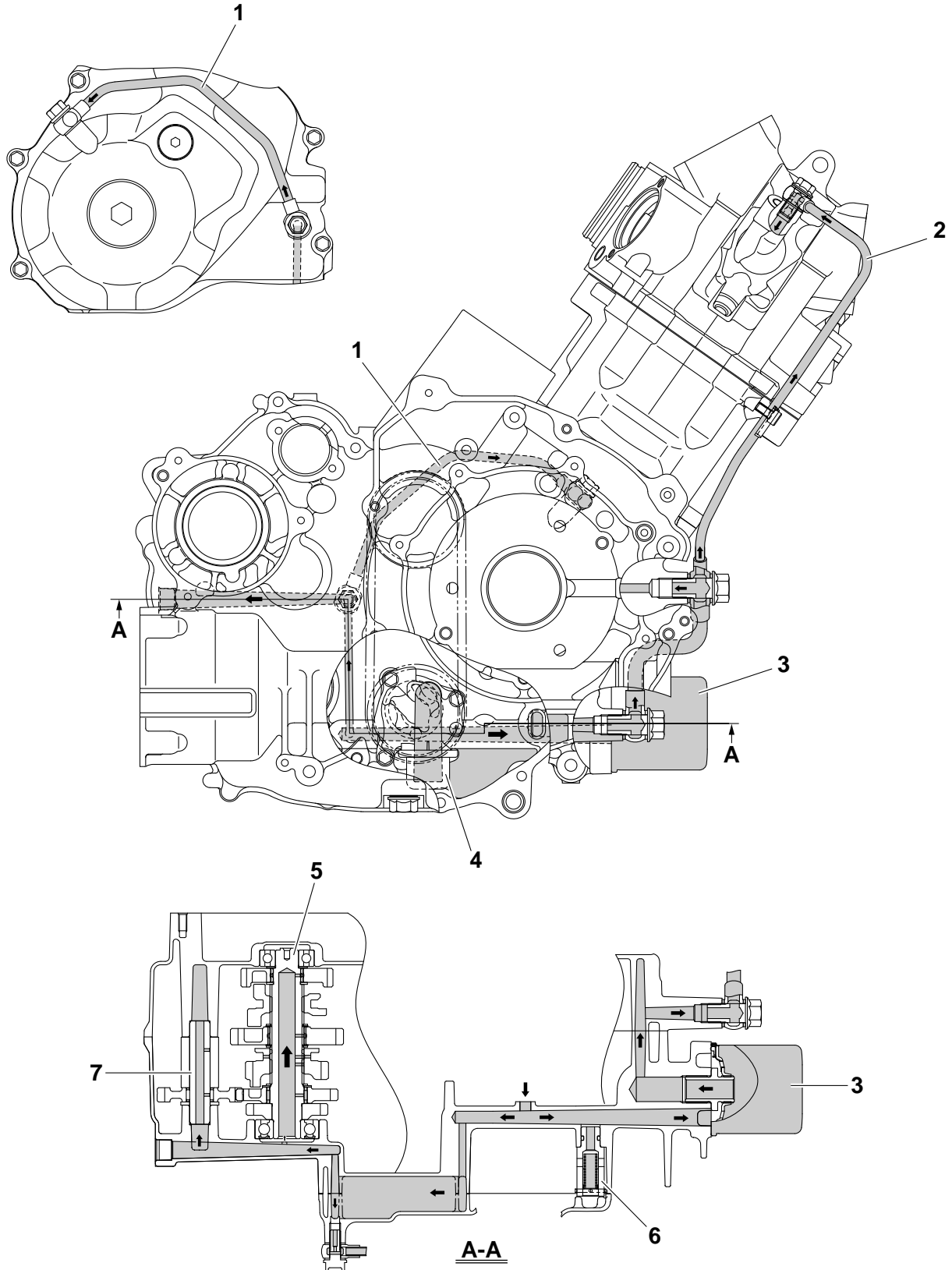

LUBRICATION SYSTEM CHART AND DIAGRAMS

1. Oil delivery pipe 1
2. Oil delivery pipe 2
3. Oil filter cartridge
4. Oil strainer
5. Drive axle
6. Relief valve assembly
7. Reverse idle gear shaft

LUBRICATION SYSTEM CHART AND DIAGRAMS

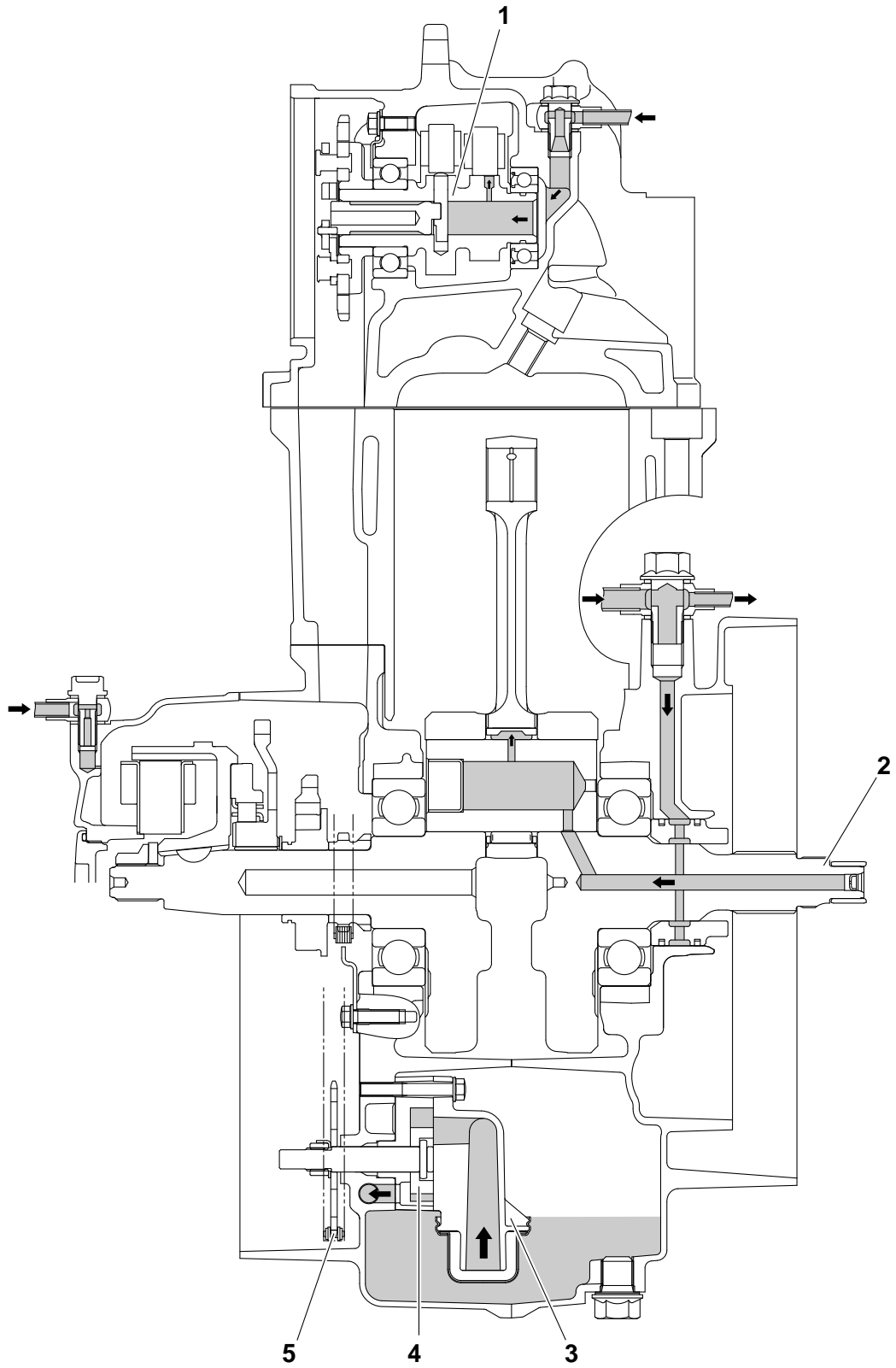

LUBRICATION SYSTEM CHART AND DIAGRAMS

1. Camshaft
2. Crankshaft
3. Oil strainer
4. Oil pump rotor
5. Oil pump driven gear

COOLING SYSTEM DIAGRAMS

EAS20420

COOLING SYSTEM DIAGRAMS

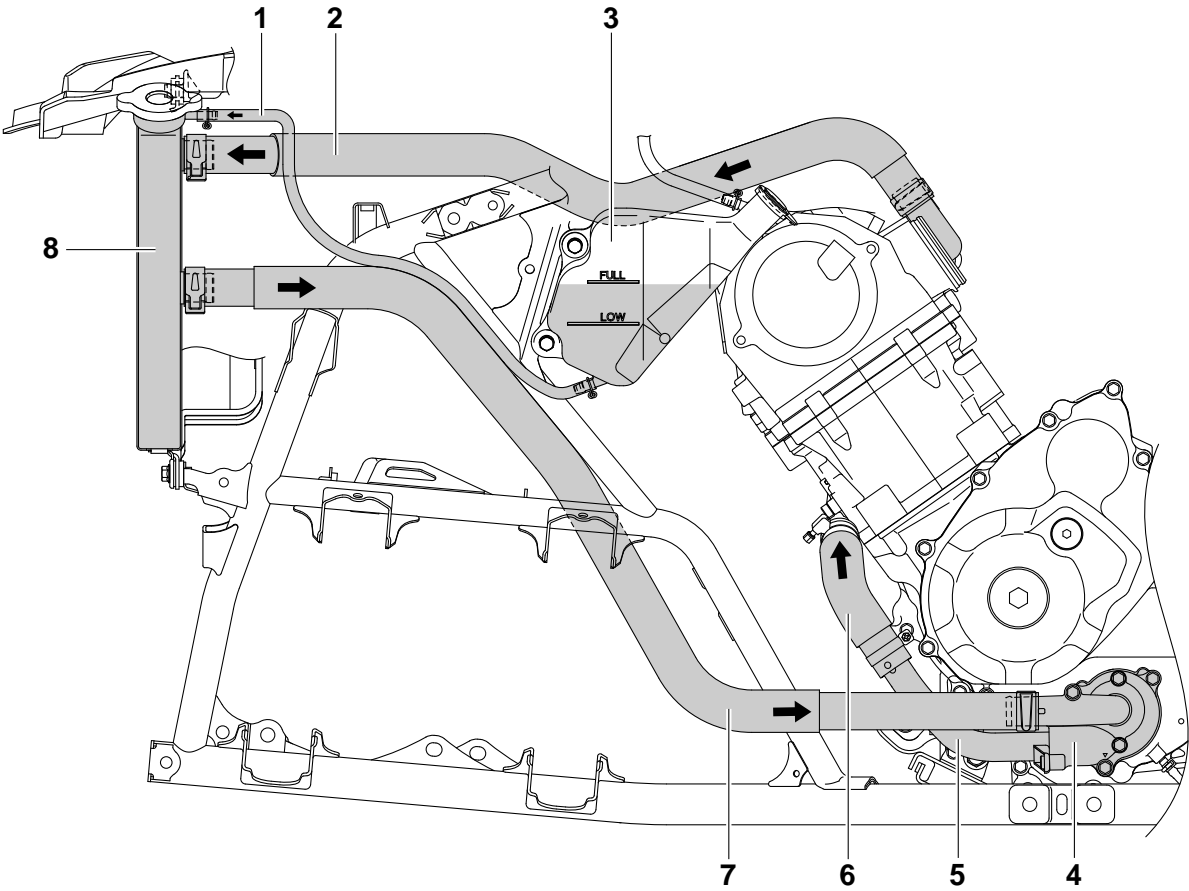

COOLING SYSTEM DIAGRAMS

1. Coolant reservoir hose
2. Radiator inlet hose
3. Coolant reservoir
4. Water pump
5. Water pump outlet pipe
6. Water pump outlet hose
7. Radiator outlet hose
8. Radiator

EAS20430

CABLE ROUTING

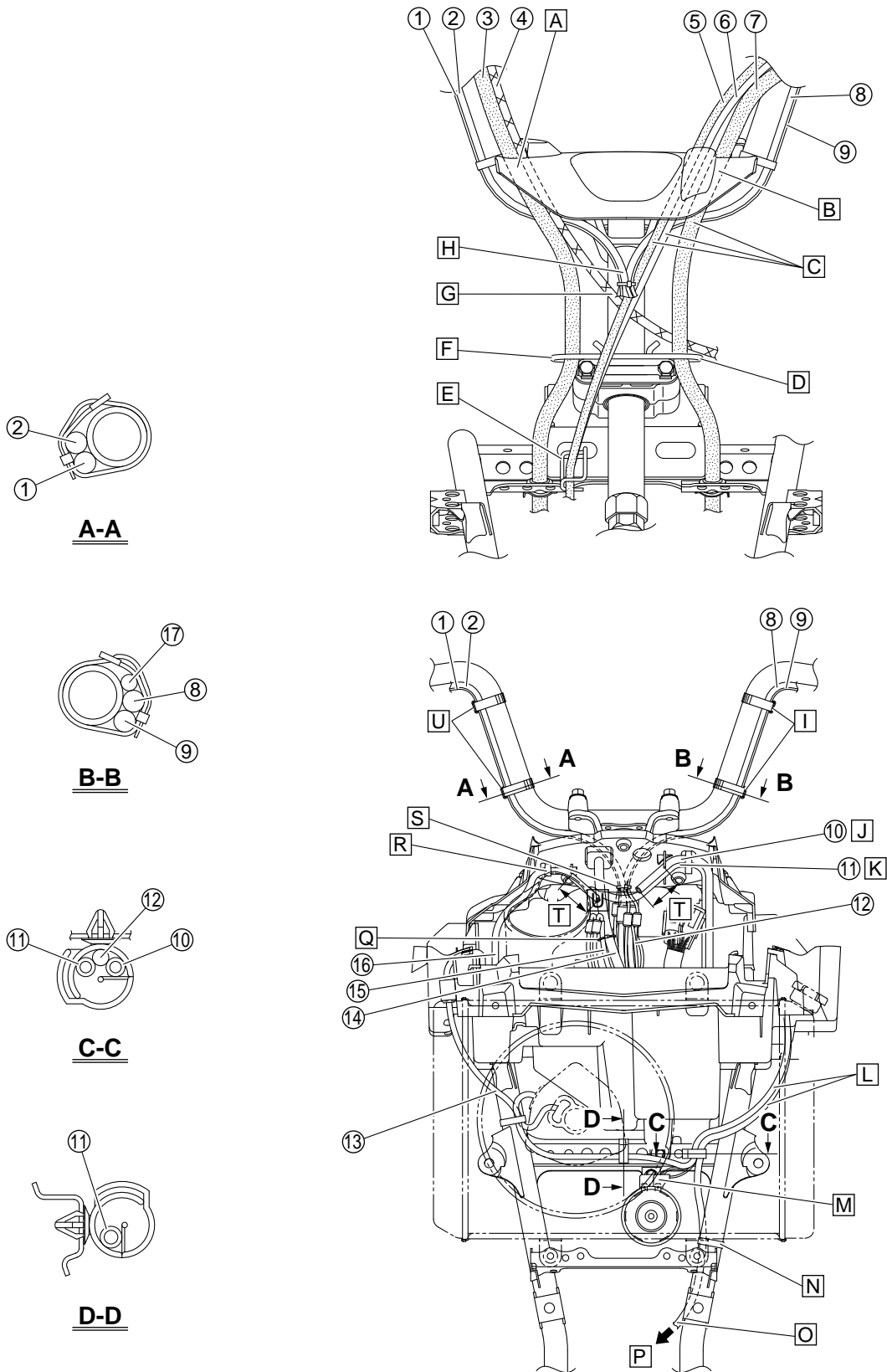

CABLE ROUTING

1. Front brake light switch lead
 2. On-command four-wheel-drive motor switch and differential gear lock switch lead
 3. Front brake hose
 4. Throttle cable
 5. Rear brake cable
 6. Shift control cable
 7. Rear brake hose
 8. Left handlebar switch lead
 9. Rear brake light switch lead
 10. Differential case breather hose
 11. Radiator fan motor breather hose
 12. Horn lead (for Europe and Oceania)
 13. Radiator fan motor lead
 14. Meter assembly lead
 15. EPS control unit lead (for EPS models)
 16. Final drive case breather hose
 17. Horn switch lead (for Europe and Oceania)
- A. Pass the front brake hose and throttle cable through the guide on the handlebar cover.
 - B. Pass the rear brake cable, shift control cable, and rear brake hose through the guide on the handlebar cover.
 - C. Route the rear brake cable, shift control cable, and rear brake hose in front of the left handlebar switch lead, rear brake light switch lead, and horn switch lead (for Europe and Oceania).
 - D. Pass the rear brake hose through the guide.
 - E. Pass the rear brake cable and shift control cable through the guide.
 - F. Pass the front brake hose through the guide.
 - G. Route the throttle cable behind the rear brake cable and shift control cable.
 - H. Route the front brake light switch lead, on-command four-wheel-drive motor switch and differential gear lock switch lead, left handlebar switch lead, rear brake light switch lead, and horn switch lead (for Europe and Oceania) over the throttle cable, rear brake cable, and shift control cable, then to the front of where the cables cross.
 - I. Fasten the left handlebar switch lead, rear brake light switch lead, and horn switch lead (for Europe and Oceania) with the plastic bands, making sure to route the leads under the handlebar and to face the ends of the bands forward. Align the plastic bands with the portions of the handlebar where the handlebar begins to bend.
 - J. Pass the differential case breather hose through the guide on the meter bracket.
 - K. Pass the radiator fan motor breather hose through the guide on the meter bracket.
 - L. Route the radiator fan motor breather hose, differential case breather hose, and horn lead (for Europe and Oceania) in front of the frame.
 - M. Install the horn L-shaped connectors so that the leads are routed to the left. (for Europe and Oceania)
 - N. Fasten the differential case breather hose to the frame with the plastic band, making sure to face the end of the band inward.
 - O. Route the differential case breather hose to the inside of the frame.
 - P. To differential assembly
 - Q. Fasten the meter assembly lead and EPS control unit lead with a plastic locking tie. Be sure to fasten the plastic locking tie around the protective sleeves of the leads, not the leads themselves. (for EPS models)
 - R. Pass the final drive case breather hose through the guide on the meter bracket.
 - S. Fasten the front brake light switch lead, on-command four-wheel-drive motor switch and differential gear lock switch lead, left handlebar switch lead, rear brake light switch lead, and horn switch lead (for Europe and Oceania) with a plastic locking tie in front of the steering stem. Be sure to fasten the plastic locking tie above the couplers and fasten it around the protective sleeves of the leads, not the leads themselves.
 - T. 20–50 mm (0.79–1.97 in)
 - U. Fasten the front brake light switch lead and on-command four-wheel-drive motor switch and differential gear lock switch lead with the plastic bands, making sure to route the leads under the handlebar and to face the ends of the bands forward. Align the plastic bands with the portions of the handlebar where the handlebar begins to bend.

CABLE ROUTING

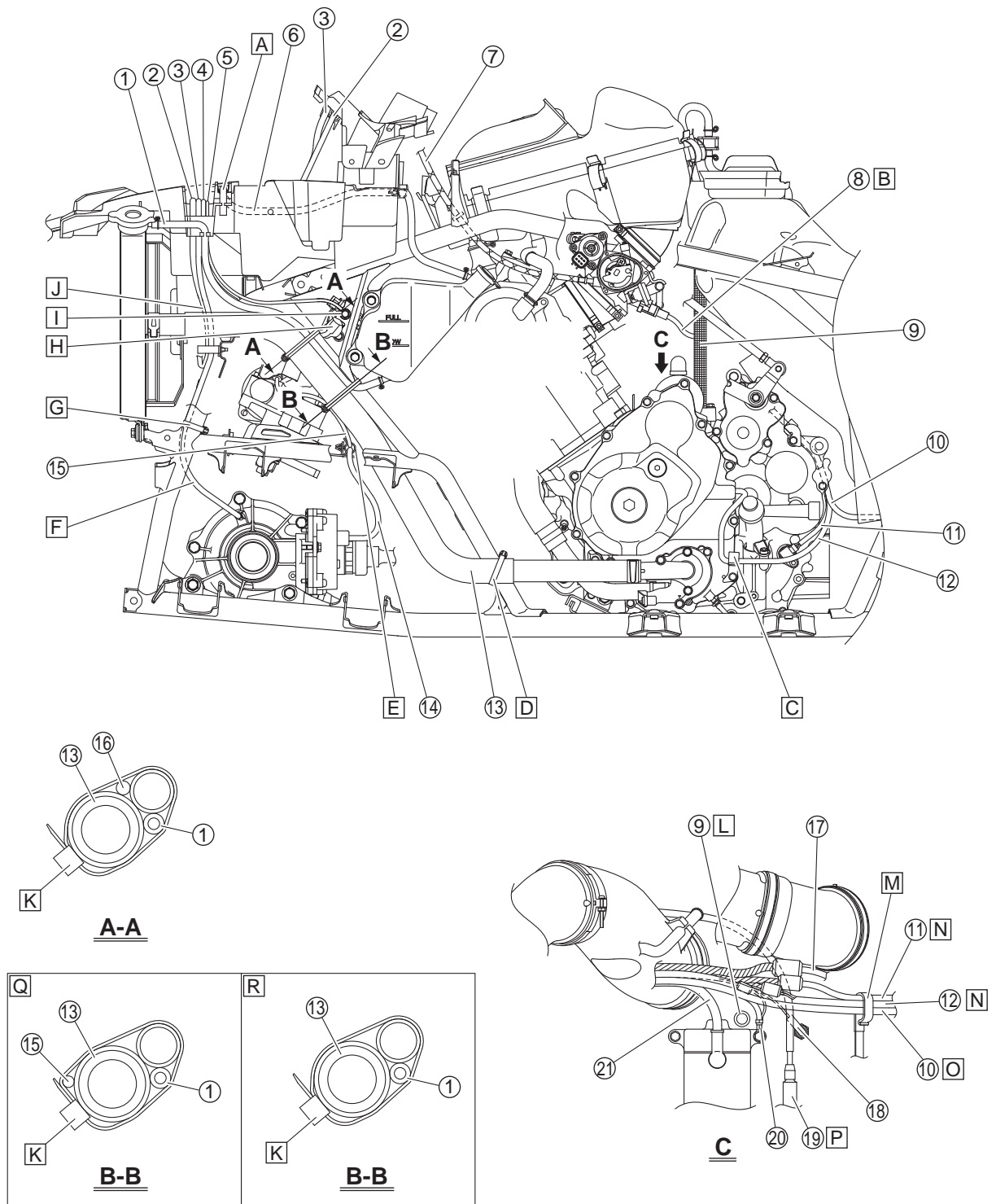

1. Coolant reservoir hose
 2. Radiator fan motor breather hose
 3. Differential case breather hose
 4. Horn lead (for Europe and Oceania)
 5. Ground lead
 6. Coolant reservoir breather hose
 7. Throttle cable
 8. Fuel injector lead
 9. Fuel tank drain hose
 10. Final drive case breather hose
 11. Speed sensor lead
 12. AC magneto/crankshaft position sensor lead
 13. Radiator outlet hose
 14. Differential motor lead
 15. EPS torque sensor lead (for EPS models)
 16. Air induction system solenoid lead
 17. Gear position switch lead
 18. Reverse switch lead
 19. Shift control cable
 20. Negative battery lead
 21. Starter motor lead
- R. Except for EPS models
- A. Face the end of the coolant reservoir breather hose downward.
 - B. Route the fuel injector lead to the inside of the fuel tank drain hose.
 - C. Pass the AC magneto/crankshaft position sensor lead through the holder.
 - D. Fasten the radiator outlet hose to the frame with the plastic band, making sure to face the end of the band inward.
 - E. Place the EPS torque sensor lead (for EPS models) and differential motor lead in the holder, and then insert the ends of the holder into the hole in the stay on the frame.
 - F. Route the differential case breather hose to the inside of the frame.
 - G. Fasten the differential case breather hose to the frame with the plastic band, making sure to face the end of the band inward.
 - H. Connect the air induction system solenoid coupler to the air cut-off valve assembly.
 - I. Attach the ground lead terminal to the frame using the bolt.
 - J. Route the radiator fan motor breather hose, differential case breather hose, and horn lead (for Europe and Oceania) to the inside of the radiator outlet hose.
 - K. Face the end of the plastic band inward.
 - L. Route the fuel tank drain hose as shown in the illustration.
 - M. Pass the speed sensor lead, AC magneto/crankshaft position sensor lead, and final drive case breather hose through the guide in the order listed.
 - N. Route the speed sensor lead and AC magneto/crankshaft position sensor lead above the reverse switch lead.
 - O. Route the final drive case breather hose above the reverse switch lead and negative battery lead.
 - P. Route the shift control cable under the gear position switch lead, speed sensor lead, AC magneto/crankshaft position sensor lead, and final drive case breather hose.
 - Q. For EPS models

CABLE ROUTING

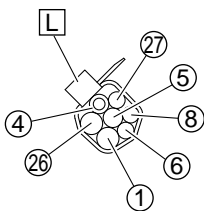
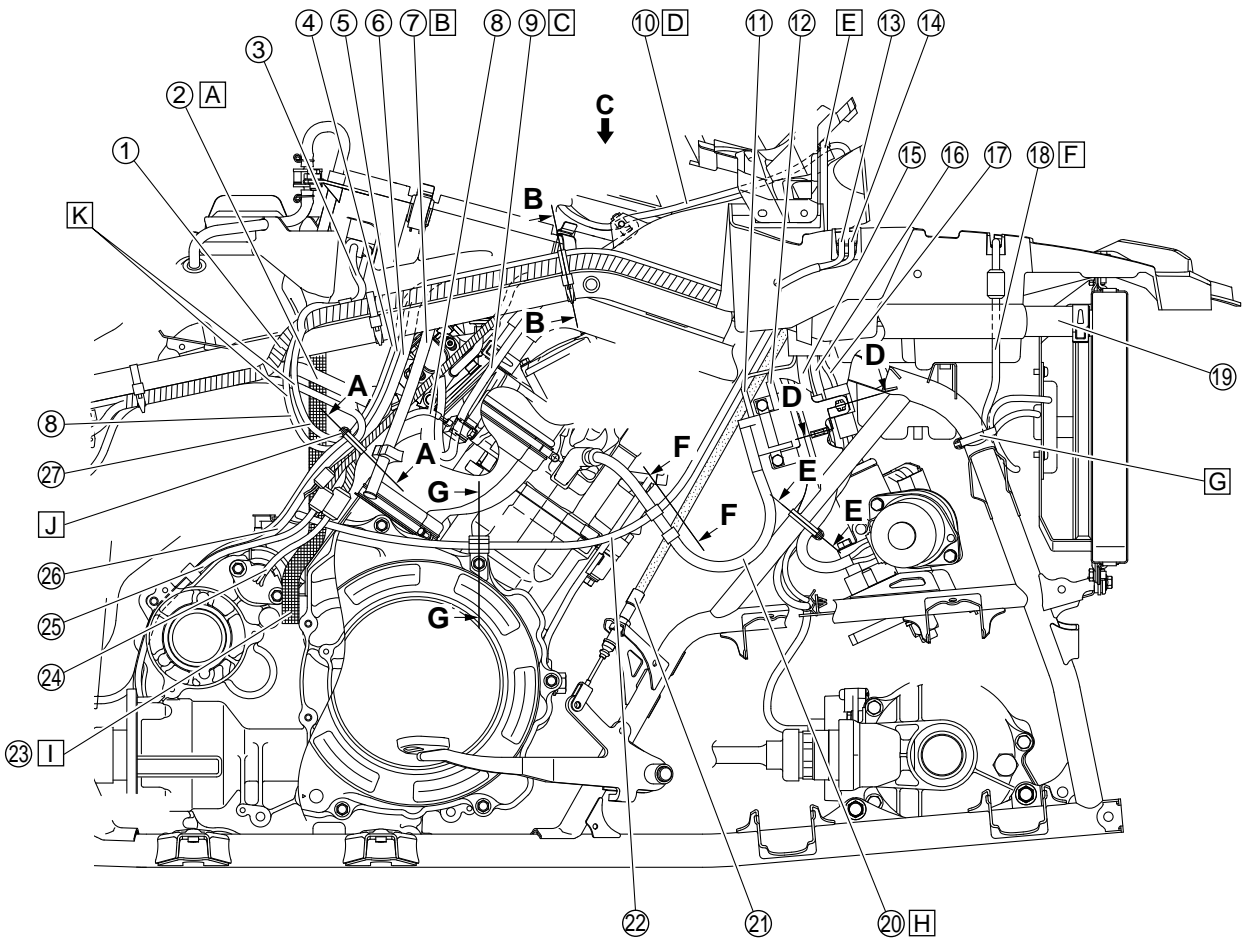

A-A

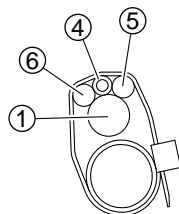

B-B

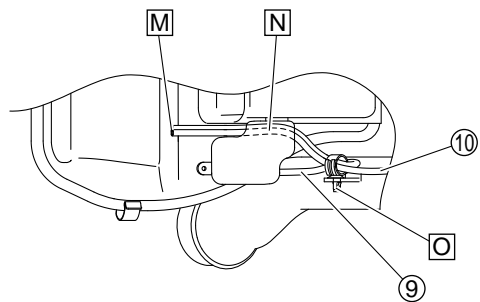

C

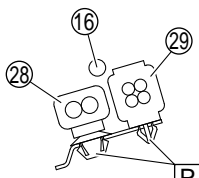

D-D

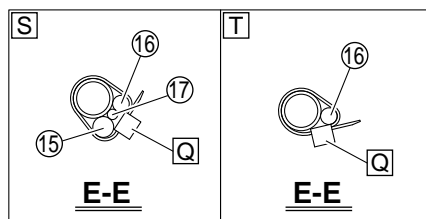

E-E

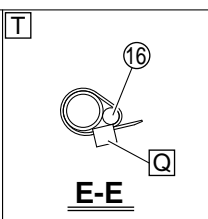

E-E

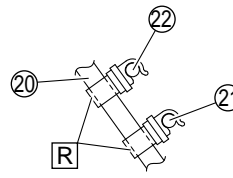

F-F



G-G

CABLE ROUTING

1. Wire harness
2. Fuel hose
3. Intake air temperature sensor lead
4. Final drive case breather hose
5. Negative battery lead
6. Starter motor lead
7. Air filter case breather hose
8. Coolant temperature sensor lead
9. Throttle body breather hose
10. Radiator fan motor breather hose
11. Ignition coil lead (red/black)
12. Ignition coil lead (red)
13. Main switch lead
14. Auxiliary DC jack lead
15. EPS motor lead (for EPS models)
16. Differential motor lead
17. EPS torque sensor lead (for EPS models)
18. Radiator fan motor lead
19. Radiator inlet hose
20. Spark plug lead
21. Rear brake cable
22. Shift control cable
23. Fuel tank drain hose
24. Gear position switch lead
25. Speed sensor lead
26. AC magneto/crankshaft position sensor lead
27. Fuel injector lead
28. EPS motor coupler (for EPS models)
29. EPS torque sensor coupler (for EPS models)
- A. Route the fuel hose between the wire harness and the fuel tank drain hose.
- B. Route the air filter case breather hose to the outside of the leads, and then fasten the hose with the holder on V-belt cooling intake duct joint.
- C. Route the throttle body breather hose under the coolant temperature sensor lead.
- D. Route the radiator fan motor breather hose above the V-belt cooling intake duct.
- E. Route the final drive case breather hose above the V-belt cooling intake duct.
- F. Route the radiator fan motor lead between the electrical components tray and the radiator inlet hose.
- G. Fasten the radiator fan motor lead and radiator fan motor breather hose to the frame with the plastic band, making sure to face the end of the band inward. Be sure to fasten the plastic band around the protective sleeves of the leads, not the leads themselves.
- H. Route the spark plug lead to the outside of the rear brake cable and shift control cable.
- I. Route the fuel tank drain hose to the inside of the leads and hoses, making sure to position the end of the drain hose as shown in the illustration.
- J. Fasten the final drive case breather hose, negative battery lead, starter motor lead, fuel injector lead, coolant temperature sensor lead, AC magneto/crankshaft position sensor lead, and wire harness with the plastic band, making sure to position the band near the split in the wire harness.
- K. Route the fuel injector lead and coolant temperature sensor lead to the inside of the negative battery lead, starter motor lead, final drive case breather hose, and wire harness.
- L. Face the end of the plastic band inward.
- M. The ends of the throttle body breather hose and radiator fan motor breather hose should extend rearward past the inlet of air filter case as shown in the illustration.
- N. Route the throttle body breather hose and radiator fan motor breather hose under the air chamber.
- O. Route the throttle body breather hose and radiator fan motor breather hose rearward and pass them through the guide.
- P. Insert the projection on each coupler into the hole in the frame from the inside of the frame. (for EPS models)
- Q. Face the end of the plastic band inward.
- R. Fasten the spark plug lead with the larger diameter section of each holder.
- S. For EPS models
- T. Except for EPS models

CABLE ROUTING

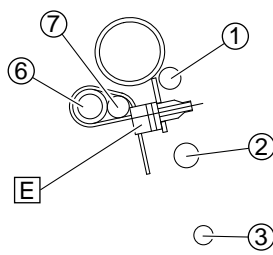
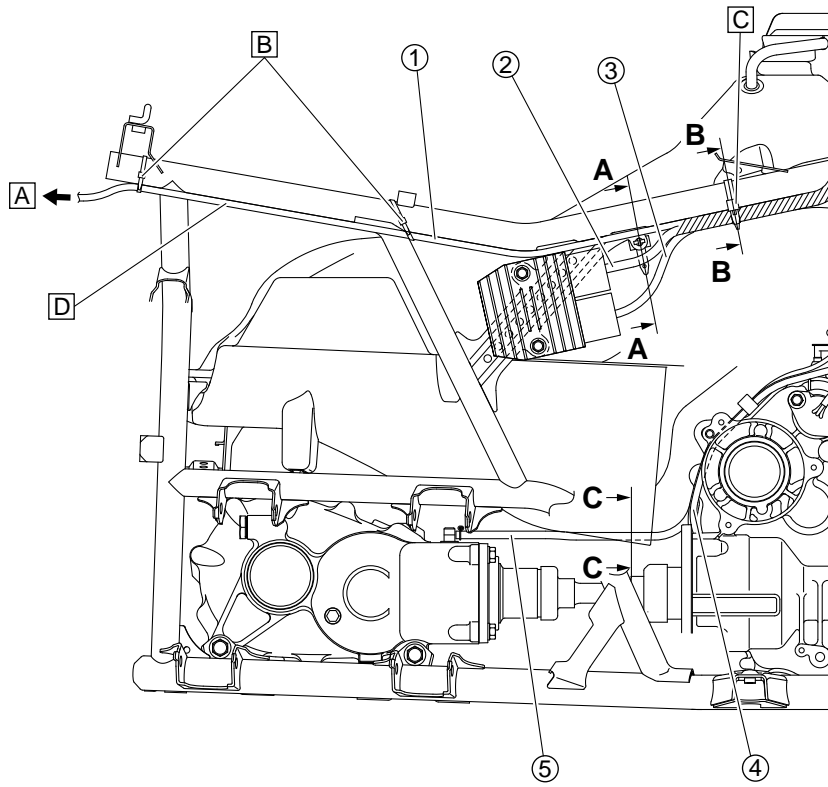

A-A

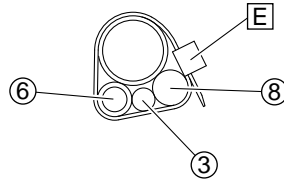

B-B

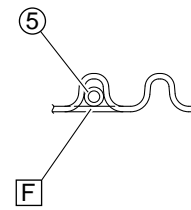

C-C

CABLE ROUTING

1. Tail/brake light lead
2. Rectifier/regulator lead
3. AC magneto lead
4. Speed sensor lead
5. Final drive case breather hose
6. Fuel hose
7. Fuel pump lead
8. Wire harness
 - A. To tail/brake light
 - B. Fasten the tail/brake light lead to the frame with plastic locking ties, making sure to face the end of each tie downward.
 - C. Install the plastic band near the split in the wire harness.
 - D. Route the tail/brake light lead to the outside of the frame.
 - E. Face the end of the plastic band downward.
 - F. Pass the final drive case breather hose through the guide.

CABLE ROUTING

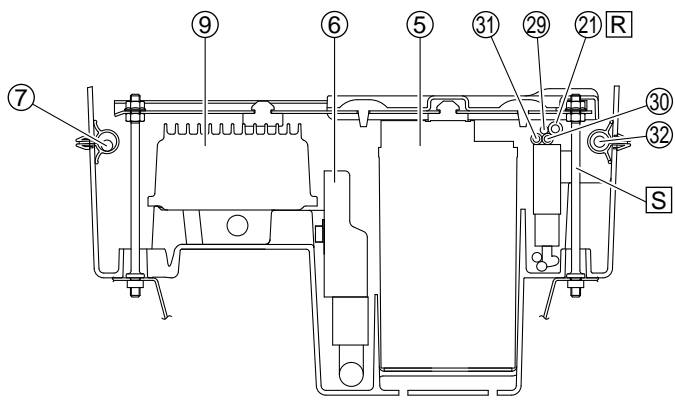
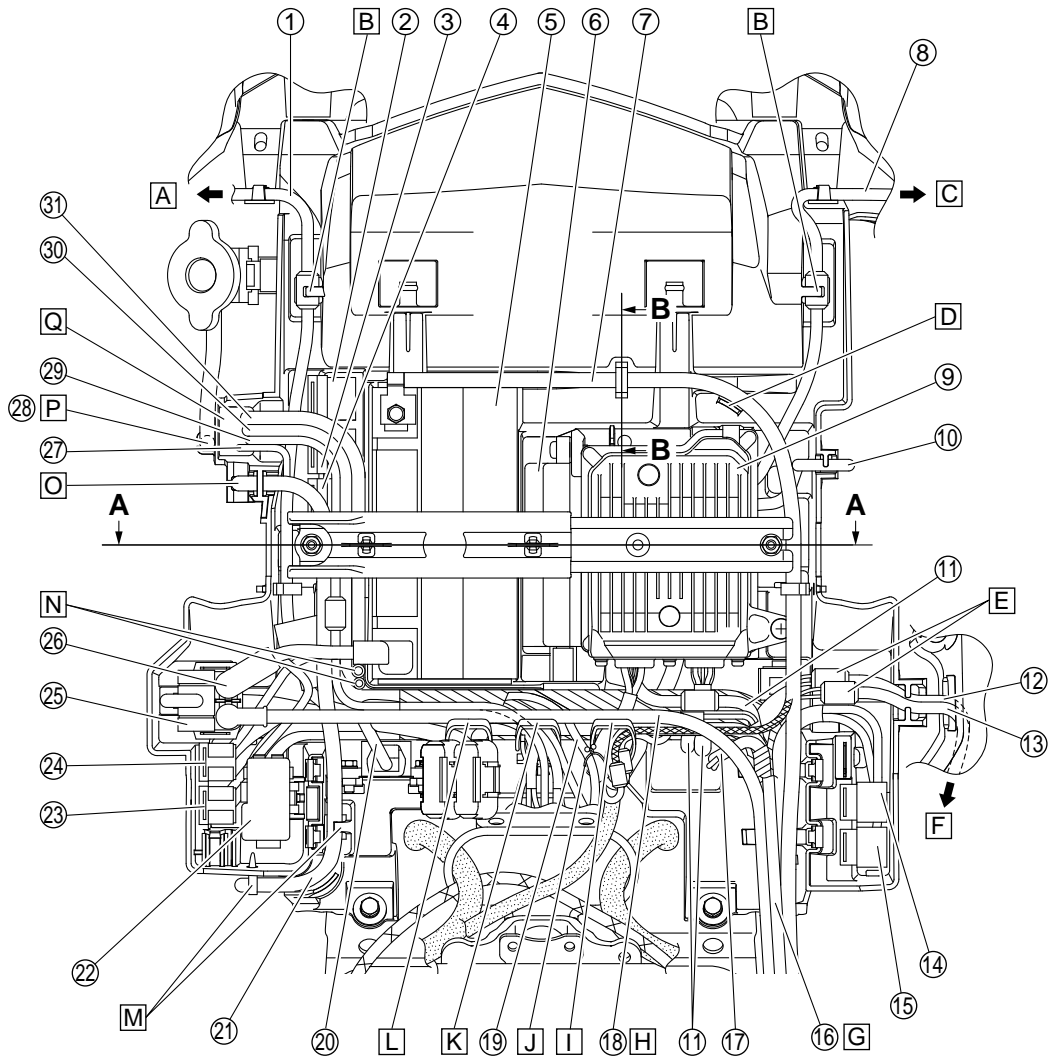

A-A

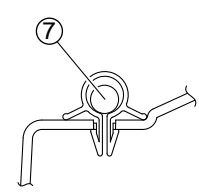

B-B

1. Left headlight lead
2. Four-wheel-drive motor relay 1
3. Four-wheel-drive motor relay 2
4. Headlight relay
5. Battery
6. ECU (engine control unit)
7. Negative battery lead
8. Right headlight lead
9. EPS (electric power steering) control unit (for EPS models)
10. Radiator fan motor lead
11. EPS control unit lead (for EPS models)
12. Auxiliary DC jack lead
13. Main switch lead
14. Radiator fan motor relay
15. Fuel injection system relay
16. Final drive case breather hose
17. Differential motor lead
18. Starter motor lead
19. Meter assembly lead
20. Lean angle sensor lead
21. Coolant reservoir breather hose
22. Fuse box
23. Main fuse
24. EPS fuse (for EPS models)
25. Starter relay
26. Positive battery lead
27. Ground lead
28. Coolant reservoir hose
29. Horn lead (for Europe and Oceania)
30. Differential case breather hose
31. Radiator fan motor breather hose
32. Wire harness
 - A. To left headlight
 - B. Connect the headlight coupler, and then fasten the coupler with the holder on the electrical components tray.
 - C. To right headlight
 - D. Route the negative battery lead along the guide on the electrical components tray.
 - E. Place the couplers on the inside of the electrical components tray.
 - F. To main switch and auxiliary DC jack
 - G. Route the final drive case breather hose above the leads in the electrical components tray.
 - H. Route the starter motor lead above the leads in the electrical components tray.
 - I. Fasten the EPS control unit lead with the holder. (for EPS models)
 - J. Fasten the meter assembly lead and EPS control unit lead (for EPS models) with the twist tie.
 - K. Fasten the left handlebar switch lead, on-command four-wheel-drive motor switch and differential gear lock switch lead, front brake light switch lead, rear brake light switch lead, and horn lead (for Europe and Oceania) with the holder.
 - L. Fasten the joint coupler lead with the holder.
 - M. Pass the coolant reservoir breather hose through the guides on the electrical components tray and route it under the positive battery lead and starter motor lead.
 - N. Route the hoses under the positive battery lead, and then route them upward, to the inside of the coolant reservoir breather hose and horn lead (for Europe and Oceania).
 - O. Fasten the coolant reservoir breather hose with the holder on the electrical components tray.
 - P. Fasten the coolant reservoir hose with the holder on the electrical components tray.
 - Q. Pass the hoses, ground lead, and horn lead (for Europe and Oceania) through the opening in the electrical components tray.
 - R. Route the coolant reservoir breather hose above the other hoses.
 - S. Route the hoses to the inside of the screw.

CABLE ROUTING

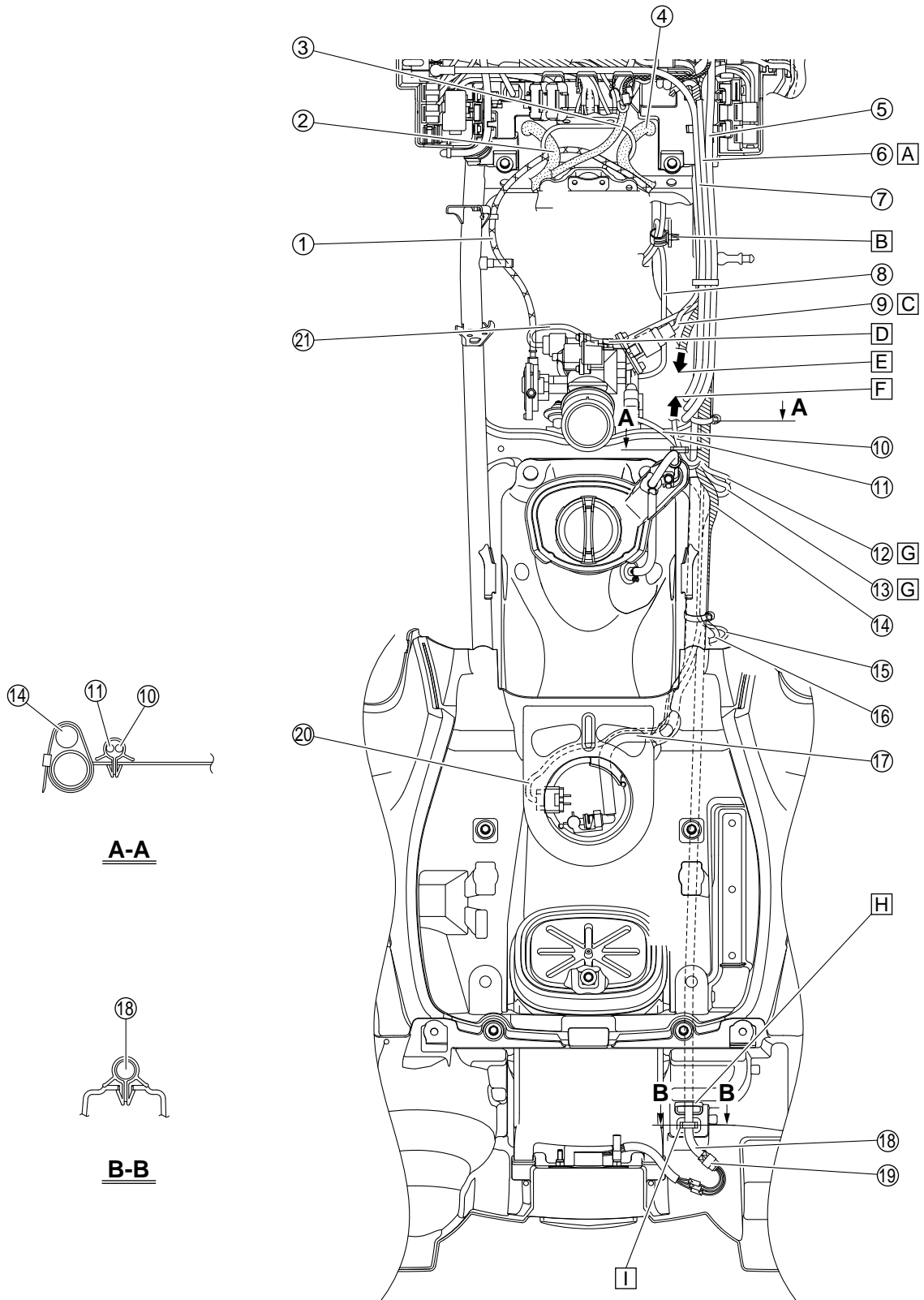

1. Throttle cable
 2. Rear brake hose
 3. Rear brake cable
 4. Front brake hose
 5. Negative battery lead
 6. Final drive case breather hose
 7. Starter motor lead
 8. Throttle body breather hose
 9. Intake air pressure sensor lead
 10. TPS lead
 11. Intake air temperature sensor lead
 12. Fuel injector lead
 13. Coolant temperature sensor lead
 14. Wire harness
 15. AC magneto lead
 16. Rectifier/regulator lead
 17. Fuel hose
 18. Tail/brake light lead
 19. Circuit breaker
 20. Fuel pump lead
 21. ISC unit lead
- A. Route the final drive case breather hose on top of the leads.
 - B. Fasten the radiator fan motor breather hose and throttle body breather hose with the holder.
 - C. Route the intake air pressure sensor lead on top of the throttle body breather hose.
 - D. Fasten the ISC unit lead with the holder.
 - E. To engine
 - F. To air filter case
 - G. Route the fuel injector lead and coolant temperature sensor lead to the outside of the frame.
 - H. Pass the tail/brake light lead through the hole in the rear fender.
 - I. Fasten the tail/brake light lead with the holder, making sure that the circuit breaker is positioned to the rear of the holder.

CABLE ROUTING

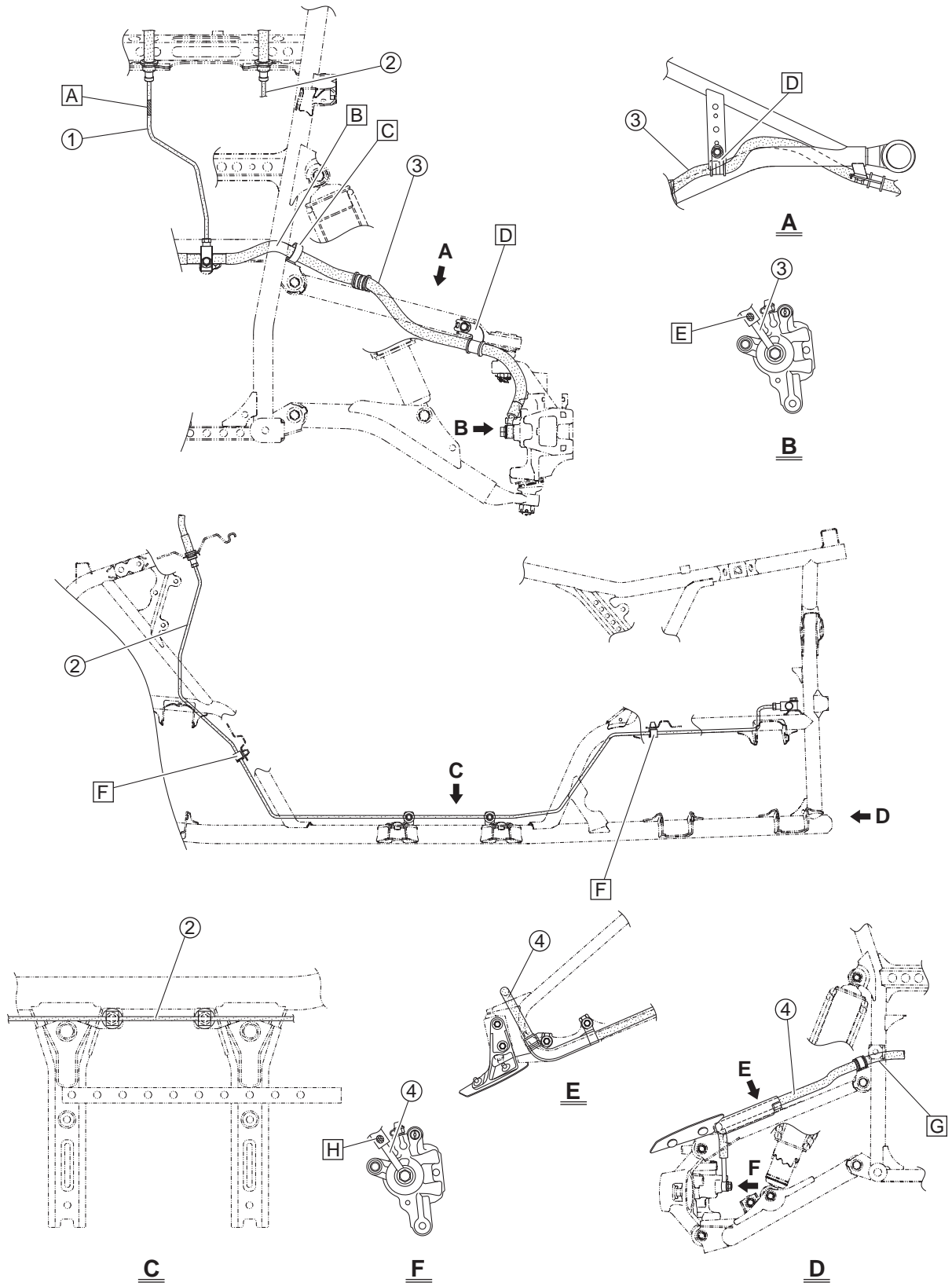

CABLE ROUTING

1. Front brake pipe
2. Rear brake pipe
3. Front brake hose
4. Rear brake hose
- A. Face the mark on the front brake pipe upward.
- B. Route the front brake hose above the frame.
- C. Pass the front brake hose through the holder.
- D. Fasten the front brake hose with the holder.
- E. Connect the end of the front brake hose that is identified by the green paint mark to the left front brake caliper.
- F. Pass the rear brake pipe through the holder.
- G. Route the rear brake hose above the frame.
- H. Connect the end of the rear brake hose that is identified by the green paint mark to the left rear brake caliper.

PERIODIC CHECKS AND ADJUSTMENTS

PERIODIC MAINTENANCE	3-1
INTRODUCTION	3-1
PERIODIC MAINTENANCE CHART FOR THE EMISSION CONTROL SYSTEM	3-1
GENERAL MAINTENANCE AND LUBRICATION CHART	3-2
ENGINE	3-4
ADJUSTING THE VALVE CLEARANCE	3-4
ADJUSTING THE EXHAUST GAS VOLUME (for Europe and Oceania)	3-6
ADJUSTING THE THROTTLE LEVER FREE PLAY	3-6
ADJUSTING THE SPEED LIMITER	3-7
CHECKING THE SPARK PLUG	3-7
MEASURING THE COMPRESSION PRESSURE	3-8
CHECKING THE ENGINE OIL LEVEL	3-9
CHANGING THE ENGINE OIL	3-9
CLEANING THE AIR FILTER ELEMENT	3-11
CHECKING THE V-BELT	3-12
REPLACING THE V-BELT	3-12
CHECKING THE THROTTLE BODY JOINT	3-13
CHECKING THE FUEL LINE	3-13
CHECKING THE BREATHER HOSES	3-13
CHECKING THE EXHAUST SYSTEM	3-14
CLEANING THE SPARK ARRESTER	3-14
CHECKING THE COOLANT LEVEL	3-15
CHECKING THE COOLING SYSTEM	3-15
CHANGING THE COOLANT	3-16
CHASSIS	3-19
ADJUSTING THE FRONT DISC BRAKE	3-19
ADJUSTING THE REAR DISC BRAKE	3-19
CHECKING THE BRAKE FLUID LEVEL	3-20
CHECKING THE FRONT BRAKE PADS	3-20
CHECKING THE REAR BRAKE PADS	3-21
CHECKING THE FRONT BRAKE HOSES	3-21
CHECKING THE REAR BRAKE HOSES	3-21
BLEEDING THE HYDRAULIC BRAKE SYSTEM	3-22
ADJUSTING THE DRIVE SELECT LEVER CONTROL CABLE AND SHIFT ROD	3-23
CHECKING THE FINAL GEAR OIL LEVEL	3-24
CHANGING THE FINAL GEAR OIL	3-24
CHECKING THE DIFFERENTIAL GEAR OIL LEVEL	3-25
CHANGING THE DIFFERENTIAL GEAR OIL	3-25
CHECKING THE CONSTANT VELOCITY SHAFT ASSEMBLY DUST BOOTS	3-26
CHECKING THE STEERING SYSTEM	3-26
ADJUSTING THE TOE-IN	3-28
CHECKING THE FRONT SHOCK ABSORBER ASSEMBLIES	3-29
ADJUSTING THE FRONT SHOCK ABSORBER ASSEMBLIES	3-29

CHECKING THE REAR SHOCK ABSORBER ASSEMBLIES.....	3-30
ADJUSTING THE REAR SHOCK ABSORBER ASSEMBLIES	3-30
CHECKING THE TIRES.....	3-31
CHECKING THE WHEELS	3-32
CHECKING AND LUBRICATING THE CABLES	3-33
LUBRICATING THE LEVERS.....	3-33
LUBRICATING THE PEDAL	3-33
ELECTRICAL SYSTEM.....	3-34
CHECKING AND CHARGING THE BATTERY	3-34
CHECKING THE FUSES	3-34
REPLACING THE HEADLIGHT BULBS	3-34
ADJUSTING THE HEADLIGHT BEAMS.....	3-34

PERIODIC MAINTENANCE

EAS20450

PERIODIC MAINTENANCE

EAS20460

INTRODUCTION

This chapter includes all information necessary to perform recommended checks and adjustments. If followed, these preventive maintenance procedures will ensure more reliable vehicle operation, a longer service life and reduce the need for costly overhaul work. This information applies to vehicles already in service as well as to new vehicles that are being prepared for sale. All service technicians should be familiar with this entire chapter.

EBU21743

PERIODIC MAINTENANCE CHART FOR THE EMISSION CONTROL SYSTEM

TIP

- For ATVs not equipped with an odometer or an hour meter, follow the month maintenance intervals.
- For ATVs equipped with an odometer or an hour meter, follow the km (mi) or hours maintenance intervals. However, keep in mind that if the ATV isn't used for a long period of time, the month maintenance intervals should be followed.
- Items marked with an asterisk should be performed by a Yamaha dealer as they require special tools, data and technical skills.

NO.	ITEM	CHECK OR MAINTENANCE JOB	Whichever comes first ⇒	INITIAL			EVERY		
				month	1	3	6	6	12
				km (mi)	320 (200)	1300 (800)	2500 (1600)	2500 (1600)	5000 (3200)
				hours	20	80	160	160	320
1	*	Fuel line	• Check fuel hoses for cracks or other damage, and replace if necessary.			√	√	√	
2		Spark plug	• Check condition and clean, regap, or replace if necessary.	√	√	√	√	√	
3	*	Valves	• Check valve clearance and adjust if necessary.	√		√	√	√	
4	*	Crankcase breather system	• Check breather hose for cracks or other damage, and replace if necessary.			√	√	√	
5	*	Exhaust system	• Check for leakage and replace gasket(s) if necessary. • Check for looseness and tighten all screw clamps and joints if necessary.			√	√	√	
6		Spark arrester	• Clean.			√	√	√	
7	*	Air induction system	• Check the air cut-off valve, reed valve, and hose for damage. • Replace any damaged parts if necessary.	√	√	√	√	√	

PERIODIC MAINTENANCE

EBU21866

GENERAL MAINTENANCE AND LUBRICATION CHART

TIP

- For ATVs not equipped with an odometer or an hour meter, follow the month maintenance intervals.
- For ATVs equipped with an odometer or an hour meter, follow the km (mi) or hours maintenance intervals. However, keep in mind that if the ATV isn't used for a long period of time, the month maintenance intervals should be followed.
- Items marked with an asterisk should be performed by a Yamaha dealer as they require special tools, data and technical skills.

NO.	ITEM	CHECK OR MAINTENANCE JOB	Whichever comes first ⇒	INITIAL			EVERY		
				month	1	3	6	6	12
				km (mi)	320 (200)	1300 (800)	2500 (1600)	2500 (1600)	5000 (3200)
hours	20	80	160	160	320				
1	Air filter element	• Clean and replace if necessary.		Every 20–40 hours (more often in wet or dusty areas)					
2	* Front brake	• Check operation and correct if necessary. • Check fluid level and ATV for fluid leakage, and correct if necessary.	√	√	√	√	√		
		• Replace brake pads.	Whenever worn to the limit						
3	* Rear brake	• Check operation and correct if necessary. • Check brake pedal free play and adjust if necessary. • Check fluid level and ATV for fluid leakage, and correct if necessary.	√	√	√	√	√		
		• Replace brake pads.	Whenever worn to the limit						
4	* Brake hoses	• Check for cracks or other damage, and replace if necessary.		√	√	√	√		
		• Replace.	Every 4 years						
5	* Brake fluid	• Replace.	Every 2 years						
6	* Wheels	• Check runout and for damage, and replace if necessary.	√		√	√	√		
7	* Tires	• Check tread depth and for damage, and replace if necessary. • Check air pressure and balance, and correct if necessary.	√		√	√	√		
8	* Wheel hub bearings	• Check for looseness or damage, and replace if necessary.	√		√	√	√		
9	* V-belt	• Check for wear, cracks or other damage, and replace if necessary.	√		√	√	√		
10	* Chassis fasteners	• Make sure that all nuts, bolts, and screws are properly tightened.	√	√	√	√	√		
11	* Shock absorber assemblies	• Check operation and correct if necessary. • Check for oil leakage and replace if necessary.			√	√	√		
12	* Stabilizer bushes	• Check for cracks or other damage, and replace if necessary.			√	√	√		
13	* Rear knuckle pivots	• Lubricate with lithium-soap-based grease.			√	√	√		
14	* Steering shaft	• Lubricate with lithium-soap-based grease.			√	√	√		
15	* Steering system	• Check operation and repair or replace if damaged. • Check toe-in and adjust if necessary.	√	√	√	√	√		
16	* Engine mount	• Check for cracks or other damage, and replace if necessary.			√	√	√		
17	* Axle boots	• Check for cracks or other damage, and replace if necessary.	√	√	√	√	√		
18	Engine oil	• Change. • Check ATV for oil leakage, and correct if necessary.	√		√	√	√		
19	Engine oil filter cartridge	• Replace.	√		√		√		

PERIODIC MAINTENANCE

NO.	ITEM	CHECK OR MAINTENANCE JOB	Whichever comes first ⇒	INITIAL			EVERY		
				month	1	3	6	6	12
				km (mi)	320 (200)	1300 (800)	2500 (1600)	2500 (1600)	5000 (3200)
hours	20	80	160	160	320				
20	Differential gear oil	<ul style="list-style-type: none"> Change. Check ATV for oil leakage, and correct if necessary. 		√				√	
21	Final gear oil	<ul style="list-style-type: none"> Change. Check ATV for oil leakage, and correct if necessary. 		√				√	
22	Cooling system	<ul style="list-style-type: none"> Check coolant level and ATV for coolant leakage, and correct if necessary. 		√	√	√	√	√	
		<ul style="list-style-type: none"> Replace coolant. 	Every 2 years						
23	* Moving parts and cables	<ul style="list-style-type: none"> Lubricate. 			√	√	√	√	
24	* Drive select lever safety system cable	<ul style="list-style-type: none"> Check operation and adjust or replace if necessary. 				√	√	√	
25	* Throttle lever	<ul style="list-style-type: none"> Check operation. Check throttle lever free play, and adjust if necessary. Lubricate cable and lever housing. 		√	√	√	√	√	
26	* Front and rear brake switches	<ul style="list-style-type: none"> Check operation and correct if necessary. 		√	√	√	√	√	
27	* Lights and switches	<ul style="list-style-type: none"> Check operation and correct if necessary. Adjust headlight beams. 		√	√	√	√	√	

EBU23071

TIP

- Some maintenance items need more frequent service if you are riding in unusually wet, dusty, sandy or muddy areas, or at full-throttle.
- Hydraulic brake service
 - Regularly check and, if necessary, correct the brake fluid level.
 - Every two years replace the internal components of the brake master cylinders and calipers, and change the brake fluid.
 - Replace the brake hoses every four years and if cracked or damaged.

EAS20472

ENGINE

EAS20520

ADJUSTING THE VALVE CLEARANCE

The following procedure applies to all of the valves.

TIP

- Valve clearance adjustment should be made on a cold engine, at room temperature.
- When the valve clearance is to be measured or adjusted, the piston must be at top dead center (TDC) on the compression stroke.

1. Remove:

- Left side panel
- Right side panel
- Front fender
- Footrest board
- Air filter case

Refer to "GENERAL CHASSIS" on page 4-1.

2. Remove:

- Intake tappet cover "1"
- Exhaust tappet cover
- Camshaft sprocket cover "2"

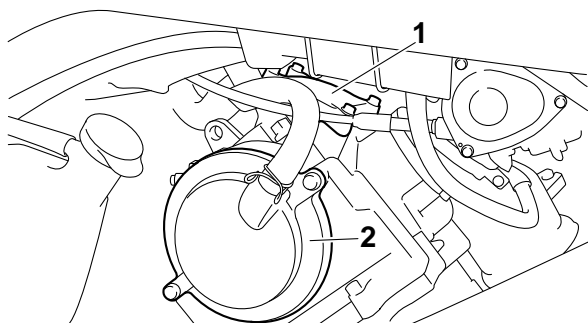

3. Disconnect:

- Spark plug cap "1"

4. Remove:

- Spark plug "2"

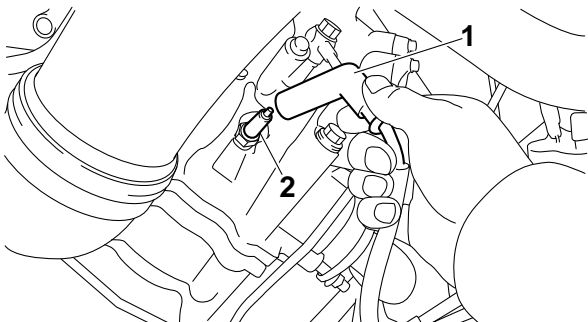

5. Remove:

- Timing mark accessing screw "1"
- Crankshaft end accessing screw "2"

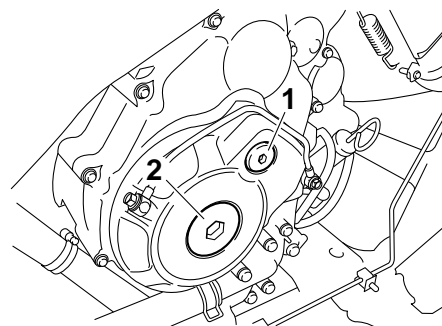

6. Measure:

- Valve clearance
- Out of specification → Adjust.



Valve clearance (cold)

Intake

0.09–0.13 mm (0.0035–0.0051 in)

Exhaust

0.16–0.20 mm (0.0063–0.0079 in)

- Turn the crankshaft counterclockwise.
- When the piston is at TDC on the compression stroke, align the "I" mark "a" on the AC magneto rotor with the stationary pointer "b" on the AC magneto cover.

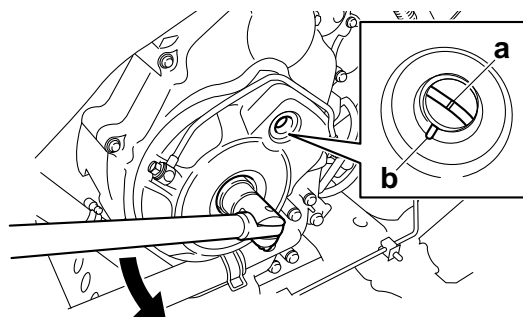

TIP

To position the piston at TDC on the compression stroke, align the "I" mark "c" on the camshaft sprocket with the stationary pointer "d" on the cylinder head, as shown in the illustration.

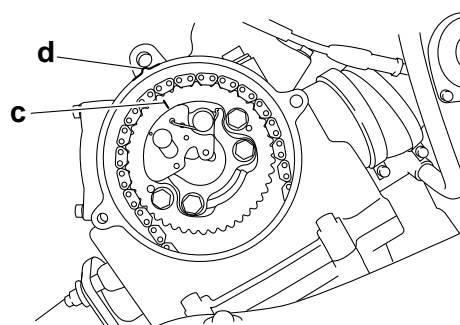

- Measure the valve clearance with a thickness gauge "1".

Out of specification → Adjust.



Thickness gauge
90890-03079
Narrow gauge set
YM-34483

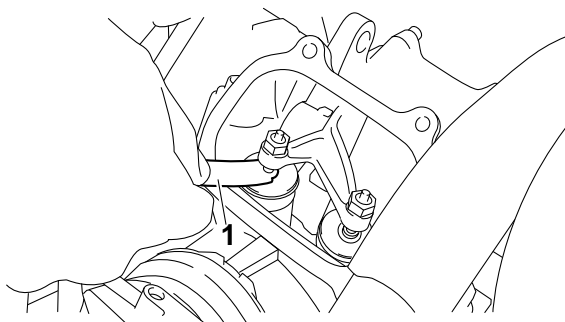

7. Adjust:
- Valve clearance



- Loosen the locknut "1".
- Insert a thickness gauge "2" between the end of the adjusting screw and the valve tip.
- Turn the adjusting screw "3" in direction "a" or "b" with the tappet adjusting tool "4" until the specified valve clearance is obtained.



Tappet adjusting tool
90890-01311
Six piece tappet set
YM-A5970

Direction "a"
Valve clearance is increased.
Direction "b"
Valve clearance is decreased.

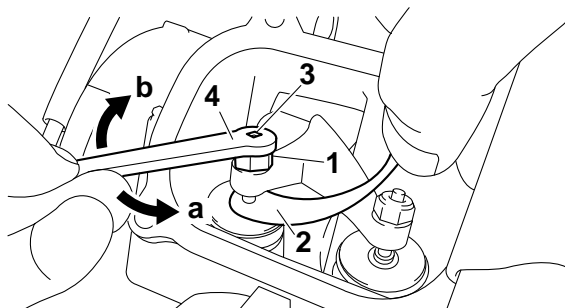

- Hold the adjusting screw to prevent it from moving and tighten the locknut to specification.



Valve adjusting screw locknut
14 Nm (1.4 m-kg, 10 ft-lb)

- Measure the valve clearance again.
- If the valve clearance is still out of specification, repeat all of the valve clearance adjustment steps until the specified clearance is obtained.



8. Install:
- Timing mark accessing screw
 - Crankshaft end accessing screw



Timing mark accessing screw
1.5 Nm (0.15 m-kg, 1.1 ft-lb)
Crankshaft end accessing screw
2 Nm (0.20 m-kg, 1.4 ft-lb)

9. Install:
- Spark plug



Spark plug
13 Nm (1.3 m-kg, 9.4 ft-lb)

10. Connect:
- Spark plug cap

11. Install:
- O-rings "1" **New**
 - Camshaft sprocket cover
 - Intake tappet cover
 - Exhaust tappet cover



Camshaft sprocket cover bolt
10 Nm (1.0 m-kg, 7.2 ft-lb)
Tappet cover bolt
10 Nm (1.0 m-kg, 7.2 ft-lb)

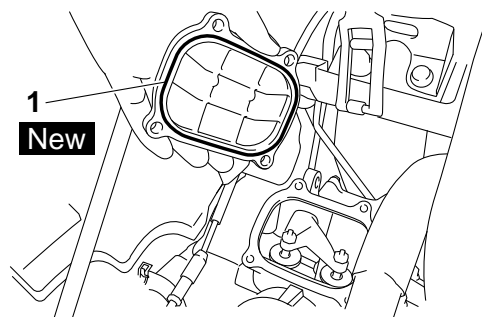

12. Install:
- Air filter case
 - Footrest board
 - Front fender
 - Right side panel
 - Left side panel
- Refer to "GENERAL CHASSIS" on page 4-1.

EAS2BG1004

ADJUSTING THE EXHAUST GAS VOLUME (for Europe and Oceania)

Use the Yamaha diagnostic tool to adjust the exhaust gas volume. For information about using the Yamaha diagnostic tool, refer to "YAMAHA DIAGNOSTIC TOOL" on page 9-38 and the operation manual that is included with the tool.

EAS20660

ADJUSTING THE THROTTLE LEVER FREE PLAY

1. Check:
 - Throttle lever free play "a"
Out of specification → Adjust.



Throttle lever free play
3.0–5.0 mm (0.12–0.20 in)

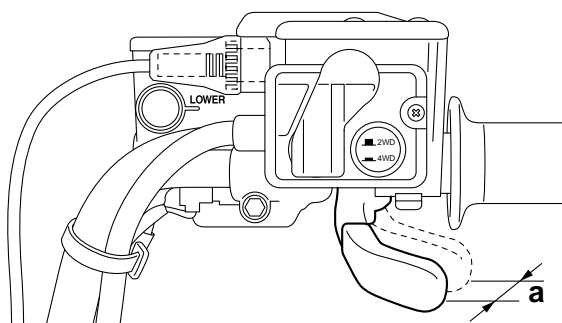

2. Remove:
 - Left side panel
Refer to "GENERAL CHASSIS" on page 4-1.
3. Adjust:
 - Throttle lever free play

Throttle body side

- a. Slide back the rubber cover "1".
- b. Loosen the locknut "2" on the throttle body side.
- c. Turn the adjusting nut "3" in direction "a" or "b" until the correct free play is obtained.

Direction "a"
Free play is increased.
Direction "b"
Free play is decreased.

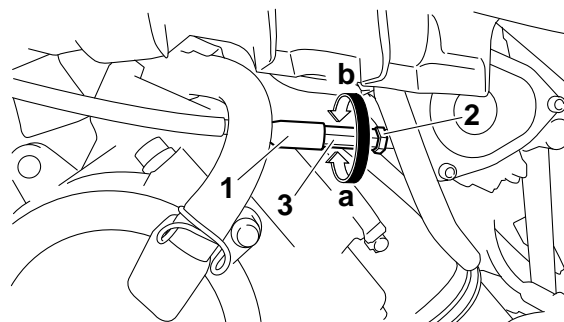

- d. Tighten the locknut.
- e. Slide the rubber cover to its original position.

TIP

If the free play cannot be adjusted here, adjust it at the handlebar side of the cable.

Handlebar side

- a. Slide back the rubber cover "1".
- b. Loosen the locknut "2".
- c. Turn the adjusting bolt "3" in direction "a" or "b" until the correct free play is obtained.

Direction "a"
Free play is increased.
Direction "b"
Free play is decreased.

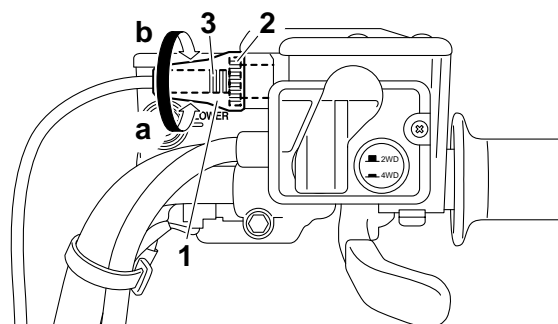

- d. Tighten the locknut.
- e. Slide the rubber cover to its original position.

EWA28P1004



WARNING

After adjusting the free play, turn the handlebar to the right and left to make sure that the engine idling speed does not increase.

4. Install:
 - Left side panel
Refer to "GENERAL CHASSIS" on page 4-1.

EAS29170

ADJUSTING THE SPEED LIMITER

The speed limiter keeps the throttle from becoming fully-opened even when the throttle lever is applied to the maximum position. Screwing in the adjusting screw stops the engine speed from increasing.

- Measure:
 - Speed limiter length
 Out of specification → Adjust.



Speed limiter length
Less than 12 mm (0.47 in)

- Adjust:
 - Speed limiter length “a”

- Loosen the locknut “1”.
- Turn the adjuster “2” in direction “b” or “c” until the specified speed limiter length is obtained.

Direction “b”
Speed limiter length is decreased.
Direction “c”
Speed limiter length is increased.

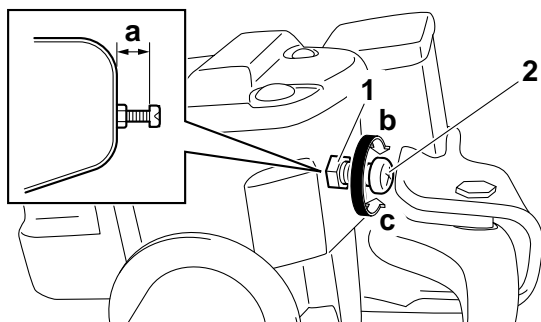

- Tighten the locknut.

EWA14880

WARNING

- Particularly for a beginner rider, the speed limiter should be screwed in completely. Screw it out little by little as their riding technique improves. Never remove the speed limiter for a beginning rider.
- For proper throttle lever operation, do not turn out the adjuster more than the specified length. Also, always adjust the throttle cable free play to within specification.

EAS20690

CHECKING THE SPARK PLUG

- Remove:
 - Right side panel
 Refer to “GENERAL CHASSIS” on page 4-1.

- Disconnect:
 - Spark plug cap
- Remove:
 - Spark plug

ECA13330

NOTICE

Before removing the spark plug, blow away any dirt accumulated in the spark plug well with compressed air to prevent it from falling into the cylinder.

- Check:
 - Spark plug type
 Incorrect → Change.



Manufacturer/model
NGK/CPR7EA-9

- Check:
 - Electrode “1”
 Damage/wear → Replace the spark plug.
 - Insulator “2”
 Abnormal color → Replace the spark plug.
Normal color is medium-to-light tan.

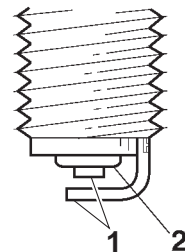

- Clean:
 - Spark plug
 (with a spark plug cleaner or wire brush)
- Measure:
 - Spark plug gap “a”
 (with a wire thickness gauge)
Out of specification → Regap.



Spark plug gap
0.8–0.9 mm (0.031–0.035 in)

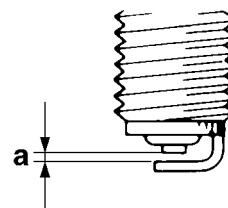

8. Install:
- Spark plug

	<p>Spark plug 13 Nm (1.3 m·kg, 9.4 ft·lb)</p>
---	--

TIP

Before installing the spark plug, clean the spark plug and gasket surface.

9. Connect:
- Spark plug cap
10. Install:
- Right side panel
- Refer to "GENERAL CHASSIS" on page 4-1.

EAS20710

MEASURING THE COMPRESSION PRESSURE

TIP

Insufficient compression pressure will result in a loss of performance.

1. Measure:
 - Valve clearance
 Out of specification → Adjust.
 Refer to "ADJUSTING THE VALVE CLEARANCE" on page 3-4.
2. Start the engine, warm it up for several minutes, and then turn it off.
3. Remove:
 - Right side panel
 Refer to "GENERAL CHASSIS" on page 4-1.
4. Disconnect:
 - Spark plug cap
5. Remove:
 - Spark plug

ECA28P1041

NOTICE

Before removing the spark plug, use compressed air to blow away any dirt accumulated in the spark plug well to prevent it from falling into the cylinder.

6. Attach:
 - Extension "1"
 - Compression gauge "2"

	<p>Compression gauge 90890-03081 Engine compression tester YU-33223 Extension 90890-04082</p>
---	--

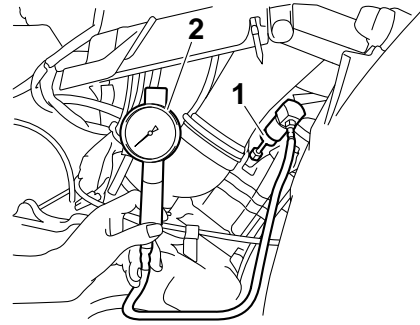

7. Measure:
 - Compression pressure
 Out of specification → Refer to steps (c) and (d).



Standard compression pressure (at sea level)
500 kPa (5.0 kgf/cm², 71.1 psi)
Minimum-maximum
440–560 kPa (4.4–5.6 kgf/cm², 62.6–79.6 psi)



- a. Set the main switch to "ON".
- b. With the throttle wide open, crank the engine until the reading on the compression gauge stabilizes.

EWA28P1005

WARNING

To prevent sparking, ground the spark plug lead before cranking the engine.

- c. If the compression pressure is above the maximum specification, check the cylinder head, valve surfaces and piston crown for carbon deposits.
 Carbon deposits → Eliminate.
- d. If the compression pressure is below the minimum specification, pour a teaspoonful of engine oil into the spark plug bore and measure again.
 Refer to the following table.

Compression pressure (with oil applied into the cylinder)	
Reading	Diagnosis
Higher than without oil	Piston ring(s) wear or damage → Repair.
Same as without oil	Piston, valves, cylinder head gasket or piston ring(s) possibly defective → Repair.



8. Install:
- Spark plug



Spark plug
13 Nm (1.3 m·kg, 9.4 ft·lb)

9. Connect:
- Spark plug cap
10. Install:
- Right side panel
- Refer to "GENERAL CHASSIS" on page 4-1.

EAS20750

CHECKING THE ENGINE OIL LEVEL

1. Place the vehicle on a level surface.
2. Check the engine oil level on a cold engine.

TIP

If the engine was started before checking the oil level, be sure to warm up the engine sufficiently, and then wait at least 10 minutes until the oil settles for an accurate reading.

3. Remove:
 - Dipstick accessing cover

Refer to "GENERAL CHASSIS" on page 4-1.
4. Check:
 - Engine oil level

The engine oil level should be between the minimum level mark "a" and maximum level mark "b".

Below the minimum level mark → Add the recommended engine oil to the proper level.

ECA28P1009

NOTICE

Do not allow foreign materials to enter the crankcase.

TIP

To obtain an accurate oil level reading, the dipstick must be inserted completely into the oil filter hole.

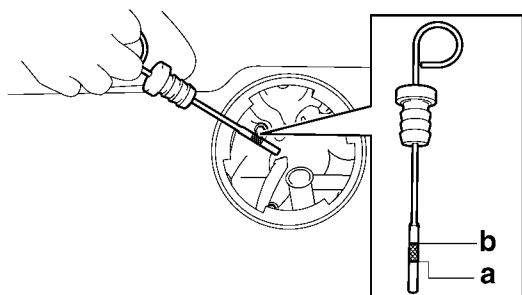

Recommended brand
YAMALUBE

Type
SAE 5W-30, 10W-30, 10W-40, 15W-40, 20W-40 or 20W-50

Recommended engine oil grade
API service SG type or higher, JASO standard MA

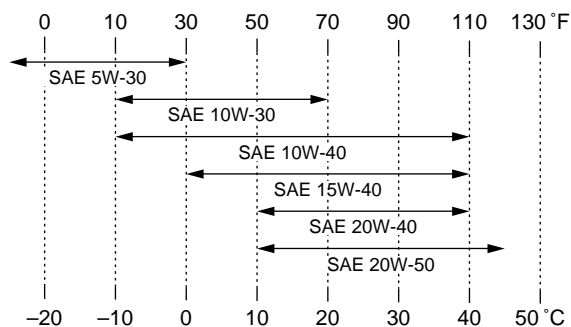

ECA1HP1001

NOTICE

- Engine oil also lubricates the clutch and the wrong oil types or additives could cause clutch slippage. Therefore, do not add any chemical additives or use engine oils with a grade of CD or higher and do not use oils labeled "ENERGY CONSERVING II".
- Do not allow foreign materials to enter the crankcase.

5. Check the engine oil level again.

ECA28P1010

NOTICE

Be sure the engine oil is at the correct level, otherwise engine damage may result.

6. Install:
 - Dipstick accessing cover

Refer to "GENERAL CHASSIS" on page 4-1.

EAS20780

CHANGING THE ENGINE OIL

1. Start the engine, warm it up for several minutes, and then turn it off.
2. Place a container under the engine oil drain bolt.
3. Remove:
 - Dipstick accessing cover

Refer to "GENERAL CHASSIS" on page 4-1.
4. Remove:
 - Dipstick "1"

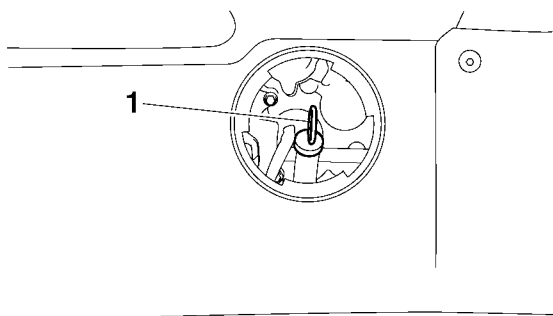

5. Remove:
- Engine oil drain bolt "1" (along with the gasket)

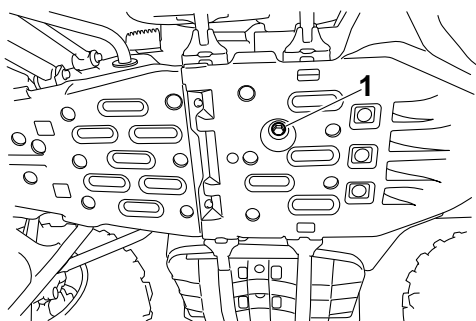

6. Drain:
- Engine oil (completely from the crankcase)
7. If the oil filter cartridge is also to be replaced, perform the following procedure.

- a. Remove the oil filter cartridge "1" with an oil filter wrench "2".

	<p>Oil filter wrench 90890-01426 YU-38411</p>
---	--

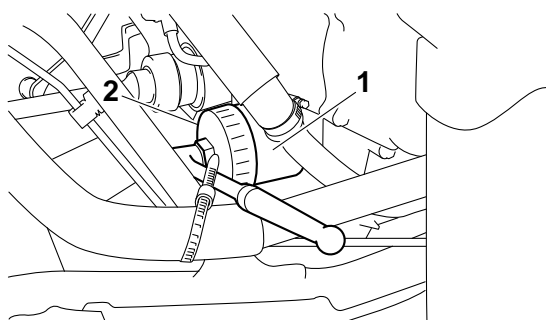

- b. Lubricate the O-ring "3" of the new oil filter cartridge with a thin coat of engine oil.

ECA13390

NOTICE

Make sure the O-ring "3" is positioned correctly in the groove of the oil filter cartridge.

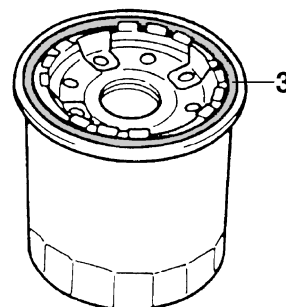

- c. Tighten the new oil filter cartridge to specification with an oil filter wrench.

	<p>Oil filter cartridge 17 Nm (1.7 m·kg, 12 ft·lb)</p>
---	---



8. Check:
- Engine oil drain bolt gasket
 Damage → Replace.
9. Install:
- Engine oil drain bolt (along with the gasket)

	<p>Engine oil drain bolt 30 Nm (3.0 m·kg, 22 ft·lb)</p>
---	--

10. Fill:
- Crankcase (with the specified amount of the recommended engine oil)

	<p>Engine oil quantity Quantity (disassembled) 2.40 L (2.54 US qt, 2.11 Imp.qt) Without oil filter cartridge replacement 2.00 L (2.11 US qt, 1.76 Imp.qt) With oil filter cartridge replacement 2.10 L (2.22 US qt, 1.85 Imp.qt)</p>
---	---

11. Install:
- Dipstick
12. Start the engine, warm it up for several minutes, and then turn it off.
13. Check:
- Engine (for engine oil leaks)
14. Check:
- Engine oil level
 Refer to "CHECKING THE ENGINE OIL LEVEL" on page 3-9.
15. Check:
- Engine oil pressure

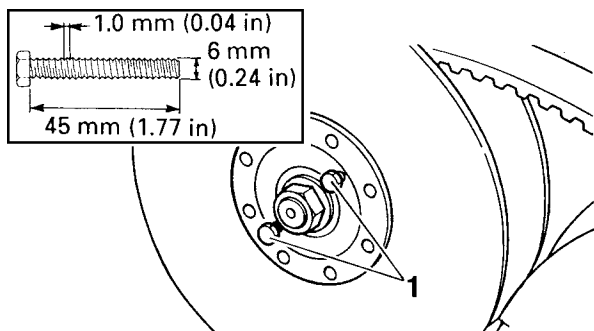

b. Remove the V-belt "2" from the primary sheave and secondary sheave.

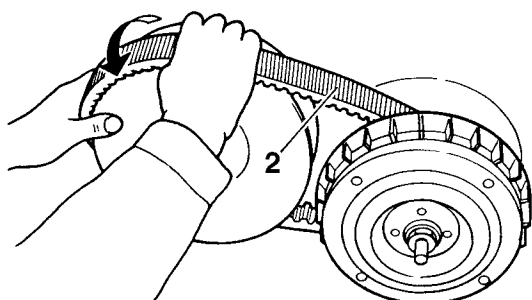

c. Install the V-belt.

TIP

Install the V-belt so that its arrow faces the direction shown in the illustration.

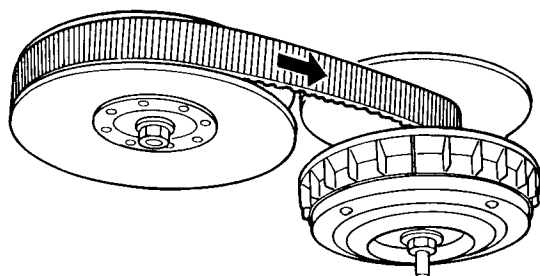

d. Remove the bolts.



EAS21020

CHECKING THE THROTTLE BODY JOINT

1. Remove:
 - Left side panel
Refer to "GENERAL CHASSIS" on page 4-1.
2. Check:
 - Throttle body joint "1"
Cracks/damage → Replace.

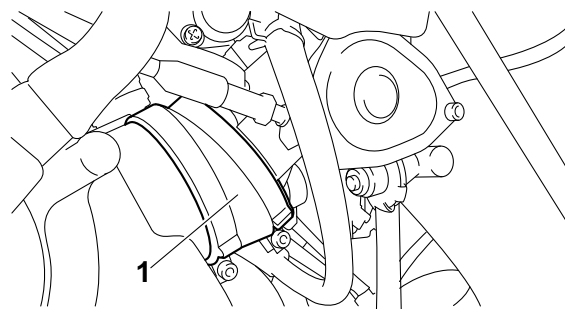

3. Install:
 - Left side panel
Refer to "GENERAL CHASSIS" on page 4-1.

EAS21030

CHECKING THE FUEL LINE

1. Remove:
 - Seat
 - Right side panel
 - Rear fender
Refer to "GENERAL CHASSIS" on page 4-1.
 - V-belt cooling exhaust duct
Refer to "ENGINE REMOVAL" on page 5-1.
2. Check:
 - Fuel hose "1"
Cracks/damage → Replace.
Loose connection → Connect properly.

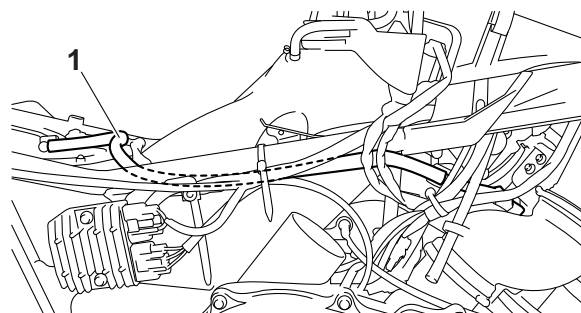

3. Install:
 - V-belt cooling exhaust duct
Refer to "ENGINE REMOVAL" on page 5-1.
 - Rear fender
 - Right side panel
 - Seat
Refer to "GENERAL CHASSIS" on page 4-1.

EAS21050

CHECKING THE BREATHER HOSES

1. Remove:
 - Left side panel
 - Air filter case
Refer to "GENERAL CHASSIS" on page 4-1.
2. Check:
 - Cylinder head breather hose "1"

- Throttle body breather hose “2”
Cracks/damage → Replace.
Loose connection → Connect properly.

ECA14920

NOTICE

Make sure the cylinder head breather hose is routed correctly.

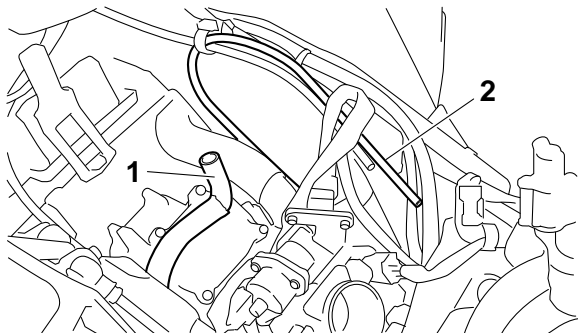

3. Install:

- Air filter case
 - Left side panel
- Refer to “GENERAL CHASSIS” on page 4-1.

EAS21080

CHECKING THE EXHAUST SYSTEM

1. Check:

- Exhaust pipe “1”
- Muffler “2”
- Exhaust pipe protector “3”
- Muffler bracket “4”
- Springs “5”
Cracks/damage → Replace.
- Gaskets “6”
Exhaust gas leaks → Replace.

2. Check:

- Tightening torque



Exhaust pipe nut “7”	20 Nm (2.0 m·kg, 14 ft·lb)
Muffler bracket bolt “8”	20 Nm (2.0 m·kg, 14 ft·lb)
Muffler bolt “9”	33 Nm (3.3 m·kg, 24 ft·lb)
Exhaust pipe protector bolt “10”	7 Nm (0.7 m·kg, 5.1 ft·lb)

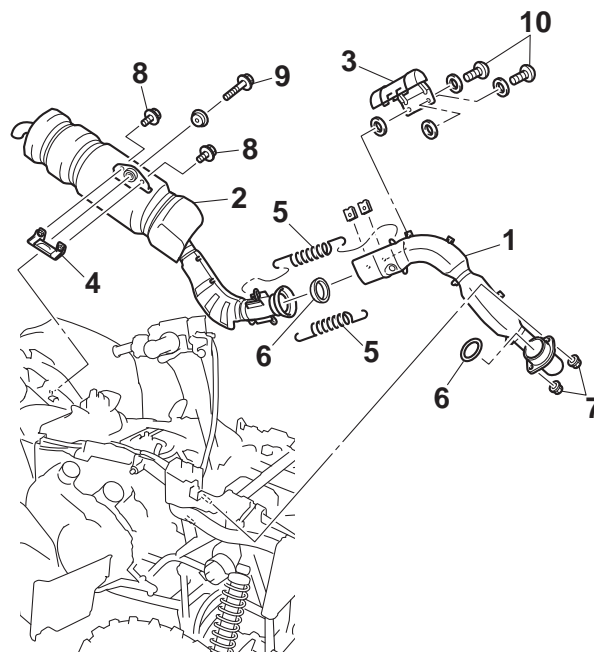

EAS28970

CLEANING THE SPARK ARRESTER

1. Clean:

- Spark arrester

EWA28P1009

WARNING

- **Select a well-ventilated area free of combustible materials.**
- **Always let the exhaust system cool before performing this operation.**
- **Do not start the engine when removing the tailpipe from the muffler.**
- **Make sure that the transmission is in neutral.**

- Remove the bolts “1”.
- Remove the tailpipe “2” by pulling it out of the muffler and the gasket.

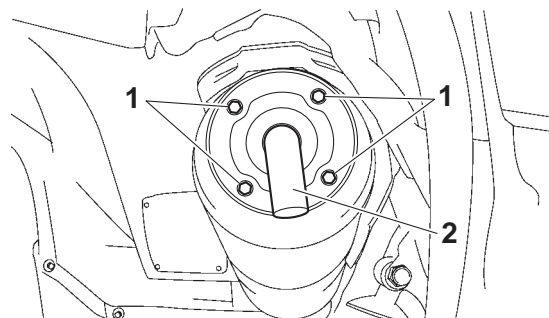

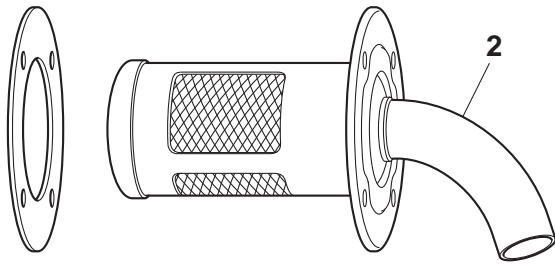

- c. Tap the tailpipe lightly with a soft-face hammer or suitable tool, then use a wire brush to remove any carbon deposits from the spark arrester portion of the tailpipe and the inner contact surfaces of the muffler.
- d. Install the gasket, and then insert the tailpipe into the muffler and align the bolt holes.
- e. Insert the bolts "1" and tighten them.



Spark arrester bolt
10 Nm (1.0 m·kg, 7.2 ft·lb)

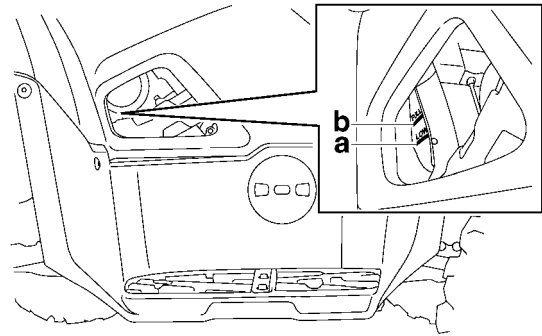

3. If the coolant is at or below the minimum level mark, remove the left side panel. Refer to "GENERAL CHASSIS" on page 4-1.
4. Remove the reservoir cap "1", add coolant or distilled water to the maximum level mark "a", install the reservoir cap, and then install the panel.



Coolant reservoir capacity (up to the maximum level mark)
0.24 L (0.25 US qt, 0.21 Imp. qt)

EAS21110

CHECKING THE COOLANT LEVEL

1. Place the vehicle on a level surface.

TIP

The coolant level must be checked on a cold engine since the level varies with engine temperature.

2. Check:

- Coolant level

The coolant level should be between the minimum level mark "a" and maximum level mark "b".

Below the minimum level mark → Add the recommended coolant to the proper level.

ECA13470

NOTICE

- Adding water instead of coolant lowers the antifreeze content of the coolant. If water is used instead of coolant check, and if necessary, correct the antifreeze concentration of the coolant.
- Use only distilled water. However, if distilled water is not available, soft water may be used.

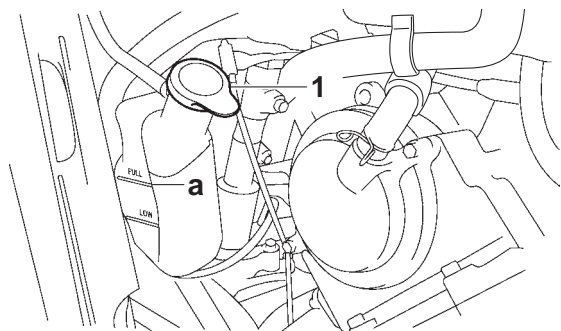

EAS21120

CHECKING THE COOLING SYSTEM

1. Remove:

- Front fenders
- Left footrest board

Refer to "GENERAL CHASSIS" on page 4-1.

2. Check:

- Radiator "1"
- Radiator inlet hose "2"
- Coolant reservoir "3"
- Coolant reservoir hose "4"
- Radiator outlet hose "5"
- Water jacket joint "6"
- Water pump outlet hose "7"
- Water pump outlet pipe "8"
- Water pump housing "9"

Cracks/damage → Replace.

Refer to "RADIATOR" on page 6-1 and "WATER PUMP" on page 6-7.

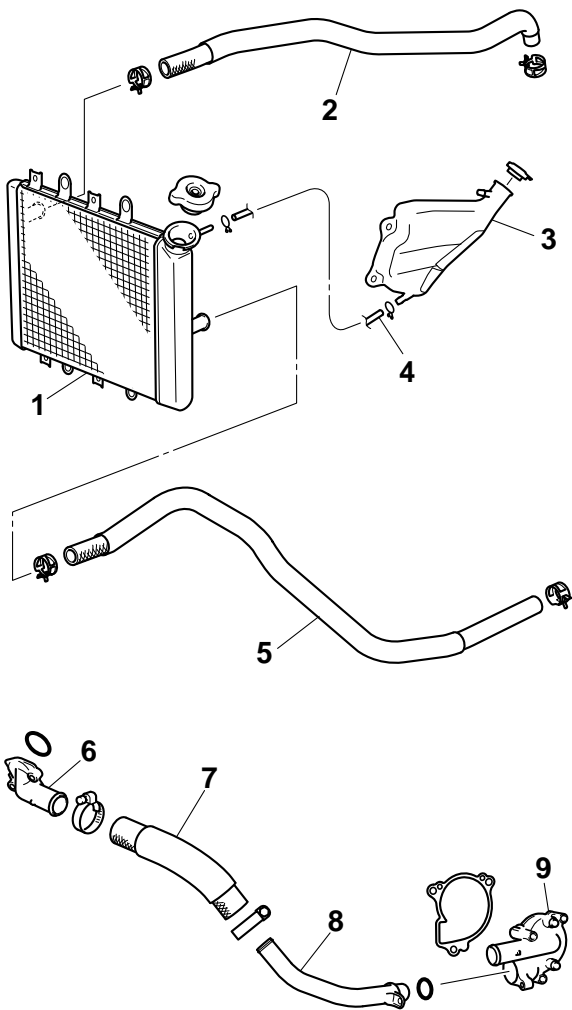

3. Install:
 - Left footrest board
 - Front fenders
 Refer to "GENERAL CHASSIS" on page 4-1.

EAS21130

CHANGING THE COOLANT

1. Remove:
 - Right side panel
 - Left side panel
 - Left footrest board
 - Front carrier
 - Upper panel
 Refer to "GENERAL CHASSIS" on page 4-1.
2. Remove:
 - Coolant reservoir cap "1"
3. Disconnect:
 - Coolant reservoir hose "2"

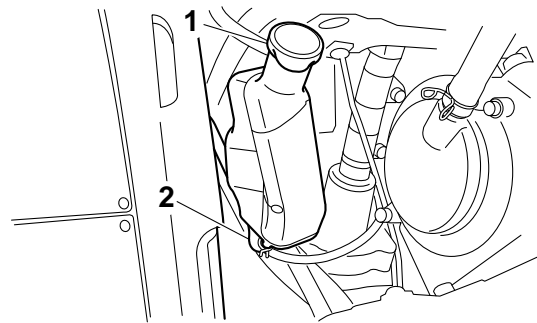

4. Drain:
 - Coolant
(from the coolant reservoir)
5. Connect:
 - Coolant reservoir hose
6. Remove:
 - Radiator cap "1"

EWA13030

WARNING

A hot radiator is under pressure. Therefore, do not remove the radiator cap when the engine is hot. Scalding hot fluid and steam may be blown out, which could cause serious injury. When the engine has cooled, open the radiator cap as follows:

Place a thick rag or a towel over the radiator cap and slowly turn the radiator cap counterclockwise toward the detent to allow any residual pressure to escape. When the hissing sound has stopped, press down on the radiator cap and turn it counterclockwise to remove.

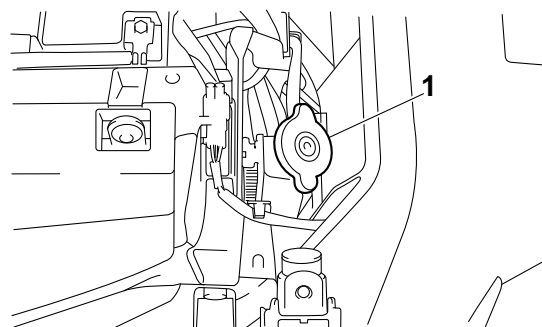

7. Remove:
 - Coolant drain bolt "1"
(along with the copper washer)

TIP

Place a container under the engine, and then remove the coolant drain bolt. (Use a trough "2" or a similar object as shown to prevent coolant from spilling on the engine guard.)

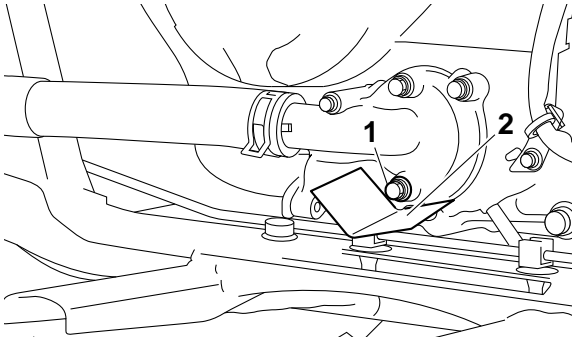

8. Drain:

- Coolant (from the engine and radiator)

9. Check:

- Coolant drain bolt "1"
Damage → Replace.

10. Install:

- Copper washer "2" **New**
- Coolant drain bolt

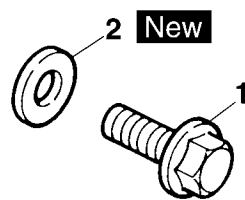
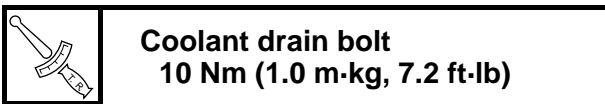

11. Fill:

- Cooling system (with the specified amount of the recommended coolant)

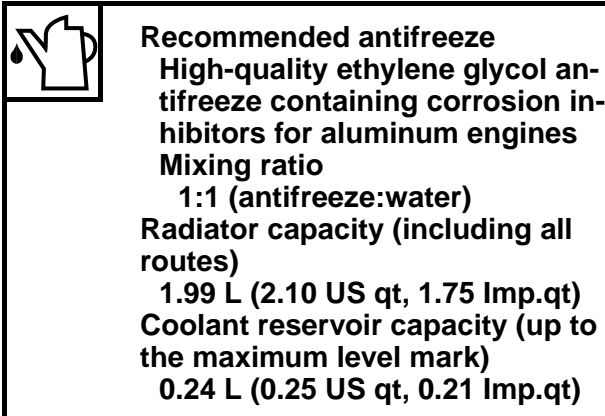

Recommended antifreeze
High-quality ethylene glycol antifreeze containing corrosion inhibitors for aluminum engines
Mixing ratio
1:1 (antifreeze:water)
Radiator capacity (including all routes)
1.99 L (2.10 US qt, 1.75 Imp.qt)
Coolant reservoir capacity (up to the maximum level mark)
0.24 L (0.25 US qt, 0.21 Imp.qt)

Handling notes for coolant

Coolant is potentially harmful and should be handled with special care.

EWA13040

WARNING

- If coolant splashes in your eyes, thoroughly wash them with water and consult a doctor.
- If coolant splashes on your clothes, quickly wash it away with water and then with soap and water.
- If coolant is swallowed, induce vomiting and get immediate medical attention.

ECA13480

NOTICE

- Adding water instead of coolant lowers the antifreeze content of the coolant. If water is used instead of coolant check, and if necessary, correct the antifreeze concentration of the coolant.
- Use only distilled water. However, if distilled water is not available, soft water may be used.
- If coolant comes into contact with painted surfaces, immediately wash them with water.
- Do not mix different types of antifreeze.

12. Fill:

- Coolant reservoir (with the recommended coolant to the maximum level mark "a")

13. Install:

- Coolant reservoir cap "1"

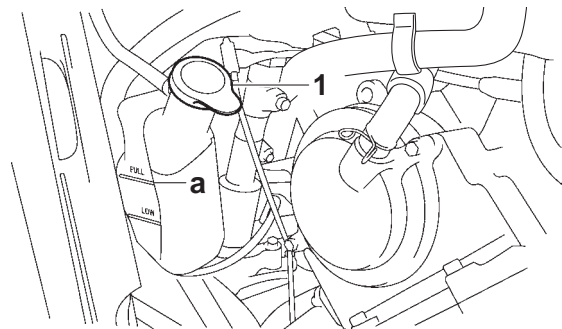

14. Bleed:

- Coolant system

- a. Remove the V-belt cooling exhaust duct "1".

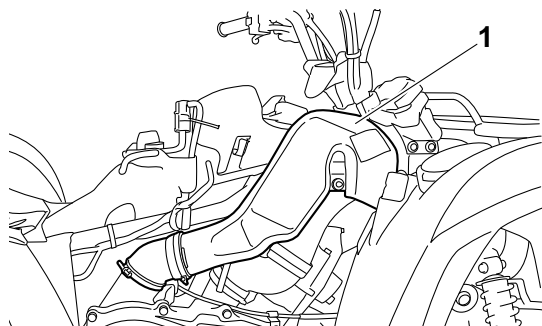

b. Loosen the water pump air bleed bolt “2”, without removing it, to allow all of the air to escape from the air bleed bolt hole.

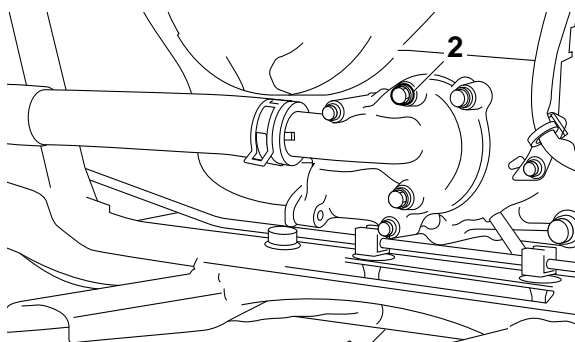

c. When coolant begins to flow out of the bolt hole, tighten the water pump air bleed bolt to specification.

	Water pump air bleed bolt 10 Nm (1.0 m-kg, 7.2 ft-lb)
---	--

d. Loosen the cylinder head air bleed bolt “3”, without removing it, to allow all of the air to escape from the air bleed bolt hole.

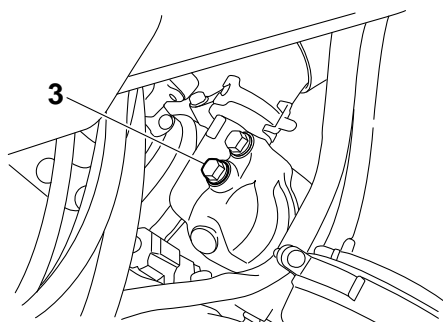

e. When coolant begins to flow out of the bolt hole, tighten the cylinder head air bleed bolt to specification.

	Cylinder head air bleed bolt 10 Nm (1.0 m-kg, 7.2 ft-lb)
---	---

f. Install the V-belt cooling exhaust duct.



15. Start the engine, warm it up for ten minutes, and then rev the engine five times.
16. Pour the recommended coolant into the radiator until it is full.
17. Stop the engine and allow it to cool. If the coolant level has dropped after the engine has cooled, add sufficient coolant until it reaches the top of the radiator, and then install the radiator cap.
18. Start the engine, and then check for coolant leakage.
 - Coolant level
Refer to “CHECKING THE COOLANT LEVEL” on page 3-15.
19. Install:
 - Upper panel
 - Front carrier
 - Left footrest board
 - Left side panel
 - Right side panelRefer to “GENERAL CHASSIS” on page 4-1.

EAS29360

CHASSIS

EAS21170

ADJUSTING THE FRONT DISC BRAKE

1. Check:

- Front brake lever free play "a"
Out of specification → Bleed the front brake system.
Refer to "BLEEDING THE HYDRAULIC BRAKE SYSTEM" on page 3-22.



Front brake lever free play (lever end)
0 mm (0 in)

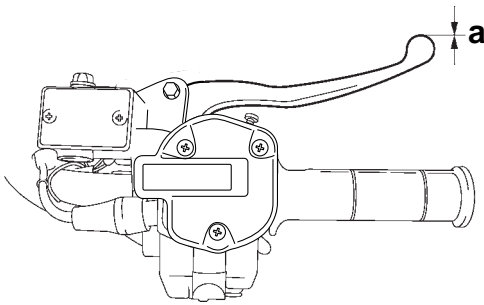

EAS29180

ADJUSTING THE REAR DISC BRAKE

EWA14890



WARNING

Always adjust both the brake pedal and the rear brake lever whenever adjusting the rear brake.

1. Check:

- Rear brake lever free play "a"
Out of specification → Bleed the rear brake system.
Refer to "BLEEDING THE HYDRAULIC BRAKE SYSTEM" on page 3-22.



Rear brake lever free play (lever end)
0 mm (0 in)

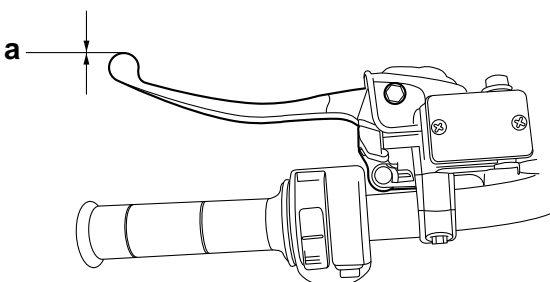

2. Check:

- Brake pedal free play "a"
Out of specification → Adjust.



Brake pedal free play
1.0–6.0 mm (0.04–0.24 in)

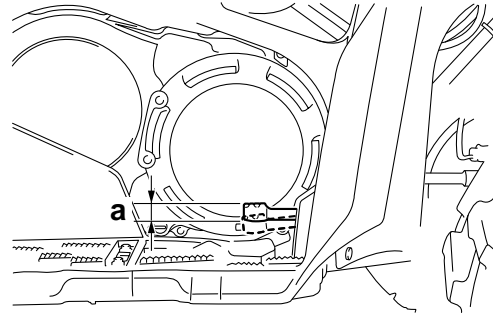

3. Adjust:

- Brake pedal free play

- Remove the front fender inner panel.
Refer to "GENERAL CHASSIS" on page 4-1.
- Loosen the adjusting nut "1" and locknut "2".
- Turn the adjusting nut "1" in direction "a" until the rear brake cable "3" is taut.
- Turn the adjusting nut "1" one turn in direction "b", and then tighten the locknut "2".
- While holding the locknut "2", tighten the adjusting nut "1".

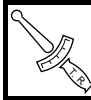

Brake pedal free play adjusting nut
7 Nm (0.7 m·kg, 5.1 ft·lb)

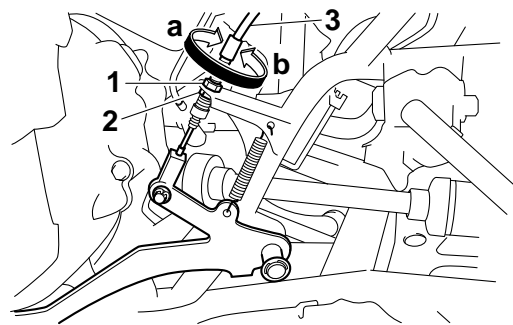

- Check that there is a gap between the rear brake cable joint (rear brake master cylinder side) "4" and the pin "5".
- Check that the brake pedal free play is within the specified limits.

TIP

When checking the brake pedal free play, make sure that the brake lever bracket "6" does not move.

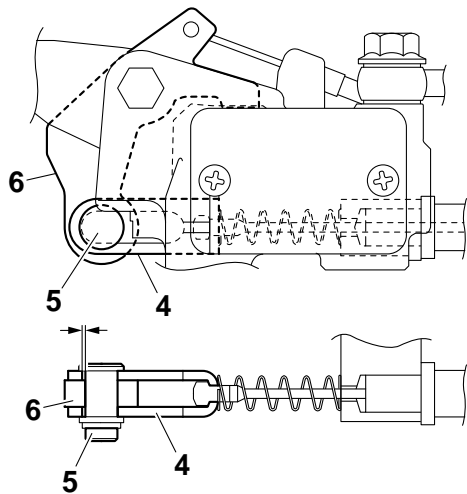

- h. Adjust the drive select lever control cable. Refer to “ADJUSTING THE DRIVE SELECT LEVER CONTROL CABLE AND SHIFT ROD” on page 3-23.

EWA14900

⚠ WARNING

After this adjustment is performed, lift the front and rear wheels off the ground by placing a block under the engine, and spin the rear wheels to ensure there is no brake drag. If any brake drag is noticed perform the above steps again.

- i. Install the front fender inner panel. Refer to “GENERAL CHASSIS” on page 4-1.



EAS21240

CHECKING THE BRAKE FLUID LEVEL

1. Place the vehicle on a level surface.

TIP

When checking the brake fluid level, make sure that the top of the brake fluid reservoir top is horizontal.

2. Check:

- Brake fluid level
Below the minimum level mark “a” → Add the specified brake fluid to the proper level.



**Specified brake fluid
DOT 4**

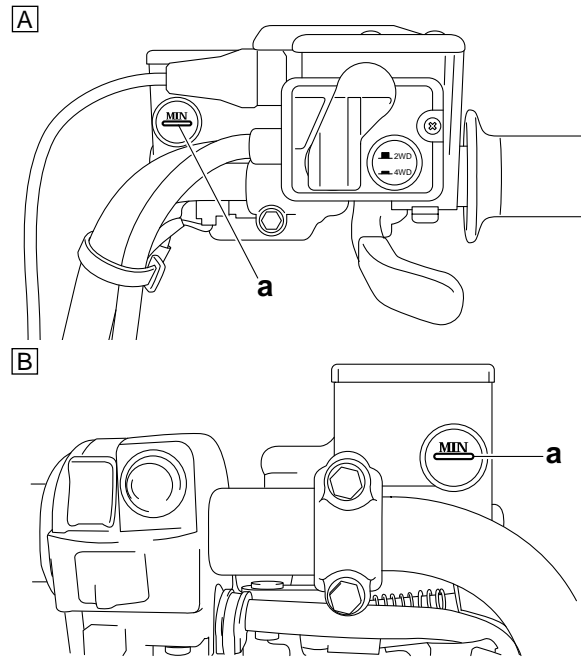

- A. Front brake
B. Rear brake

EWA13090

⚠ WARNING

- Use only the designated brake fluid. Other brake fluids may cause the rubber seals to deteriorate, causing leakage and poor brake performance.
- Refill with the same type of brake fluid that is already in the system. Mixing brake fluids may result in a harmful chemical reaction, leading to poor brake performance.
- When refilling, be careful that water does not enter the brake fluid reservoir. Water will significantly lower the boiling point of the brake fluid and could cause vapor lock.

ECA13540

NOTICE

Brake fluid may damage painted surfaces and plastic parts. Therefore, always clean up any spilt brake fluid immediately.

TIP

In order to ensure a correct reading of the brake fluid level, make sure the top of the brake fluid reservoir is horizontal.

EAS21250

CHECKING THE FRONT BRAKE PADS

The following procedure applies to all of the brake pads.

1. Remove:
 - Front wheels
Refer to "FRONT WHEELS" on page 4-14.
2. Operate the brake.
3. Check:
 - Front brake pads
A wear indicator groove "a" has almost disappeared → Replace the brake pads and brake pad spring as a set.
Refer to "FRONT BRAKE" on page 4-21.

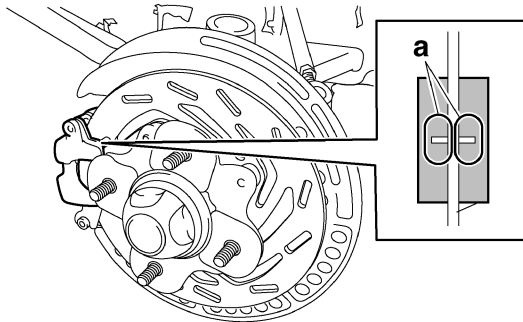

4. Install:
 - Front wheels
Refer to "FRONT WHEELS" on page 4-14.

EAS21260

CHECKING THE REAR BRAKE PADS

The following procedure applies to all of the brake pads.

1. Remove:
 - Rear wheels
Refer to "REAR WHEELS" on page 4-18.
2. Operate the brake.
3. Check:
 - Rear brake pads
A wear indicator groove "a" has almost disappeared → Replace the brake pads and brake pad spring as a set.
Refer to "REAR BRAKE" on page 4-32.

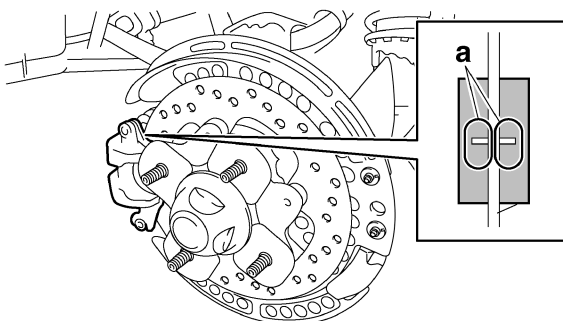

4. Install:
 - Rear wheels
Refer to "REAR WHEELS" on page 4-18.

EAS21280

CHECKING THE FRONT BRAKE HOSES

The following procedure applies to all of the brake hoses and brake hose clamps.

1. Check:
 - Front brake hoses "1"
Cracks/damage/wear → Replace.

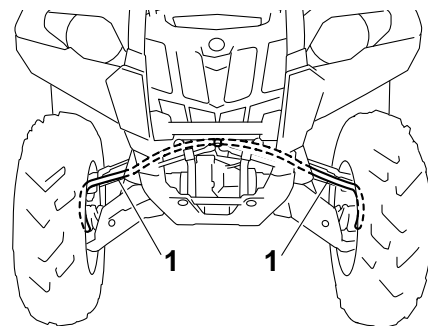
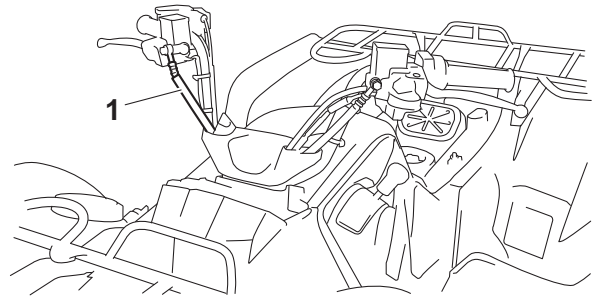

2. Check:
 - Brake hose holders
Loose → Tighten the holder bolt.
3. Apply the brake several times.
4. Check:
 - Brake hoses
Brake fluid leakage → Replace the damaged hose.
Refer to "FRONT BRAKE" on page 4-21.

EAS21290

CHECKING THE REAR BRAKE HOSES

The following procedure applies to all of the brake hoses and brake hose clamps.

1. Check:
 - Rear brake hoses "1"
Cracks/damage/wear → Replace.

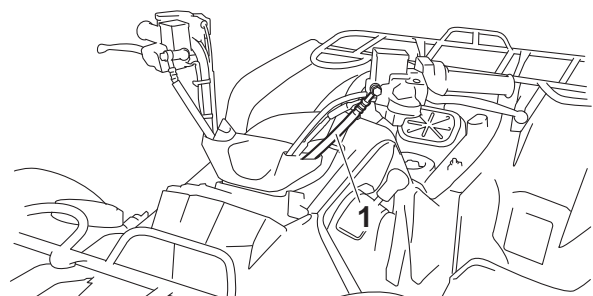

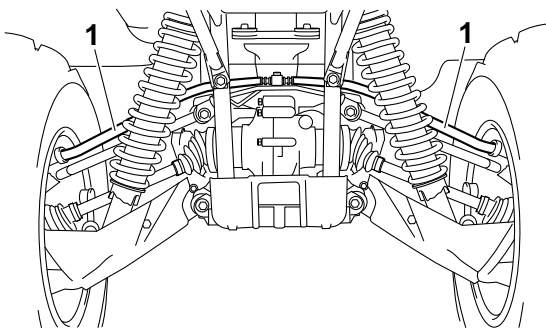

2. Check:
 - Brake hose holders
Loose → Tighten the clamp bolt.
3. Apply the brake several times.
4. Check:
 - Brake hoses
Brake fluid leakage → Replace any damaged hose.
Refer to "REAR BRAKE" on page 4-32.

EAS21350

BLEEDING THE HYDRAULIC BRAKE SYSTEM

EWA13100

WARNING

Bleed the hydraulic brake system whenever:

- the system is disassembled.
- a brake hose is loosened, disconnected or replaced.
- the brake fluid level is very low.
- brake operation is faulty.

TIP

- Be careful not to spill any brake fluid or allow the brake master cylinder reservoir or brake fluid reservoir to overflow.
- When bleeding the hydraulic brake system, make sure there is always enough brake fluid before applying the brake. Ignoring this precaution could allow air to enter the hydraulic brake system, considerably lengthening the bleeding procedure.
- If bleeding is difficult, it may be necessary to let the brake fluid settle for a few hours. Repeat the bleeding procedure when the tiny bubbles in the hose have disappeared.

1. Remove:
 - Rear wheels
Refer to "REAR WHEELS" on page 4-18.
2. Bleed:
 - Hydraulic brake system

- a. Fill the brake fluid reservoir to the proper level with the specified brake fluid.

- b. Install the diaphragm (brake master cylinder reservoir).
- c. Connect a clear plastic hose "1" tightly to the bleed screw "2".

A

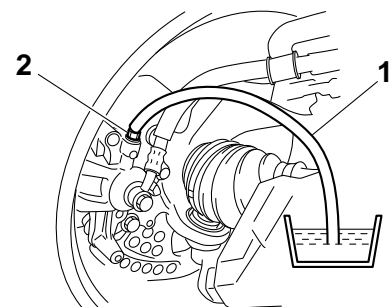

B

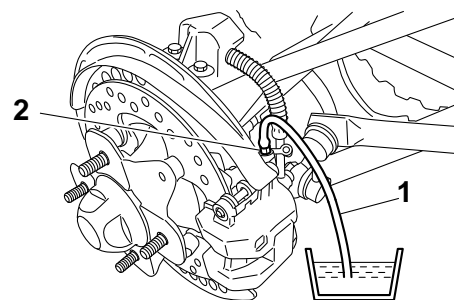

A. Front brake

B. Rear brake

- d. Place the other end of the hose into a container.
- e. Slowly apply the brake several times.
- f. Fully pull the brake lever or fully press down the brake pedal and hold it in position.
- g. Loosen the bleed screw.

TIP

Loosening the bleed screw will release the pressure and cause the brake lever to touch the throttle grip or the brake pedal to fully extend.

- h. Tighten the bleed screw and then release the brake lever or brake pedal.
- i. Repeat steps (e) to (h) until all of the air bubbles have disappeared from the brake fluid in the plastic hose.
- j. Tighten the bleed screw to specification.



**Bleed screw
5 Nm (0.5 m·kg, 3.6 ft·lb)**

- k. Fill the brake fluid reservoir to the proper level with the specified brake fluid.
Refer to "CHECKING THE BRAKE FLUID LEVEL" on page 3-20.

EWA13110

WARNING

After bleeding the hydraulic brake system, check the brake operation.

3. Install:

- Rear wheels
Refer to "REAR WHEELS" on page 4-18.

EAS29220

ADJUSTING THE DRIVE SELECT LEVER CONTROL CABLE AND SHIFT ROD

ECA28P1012

NOTICE

Before moving the drive select lever, bring the vehicle to a complete stop and return the throttle lever to its closed position. Otherwise, the transmission may be damaged.

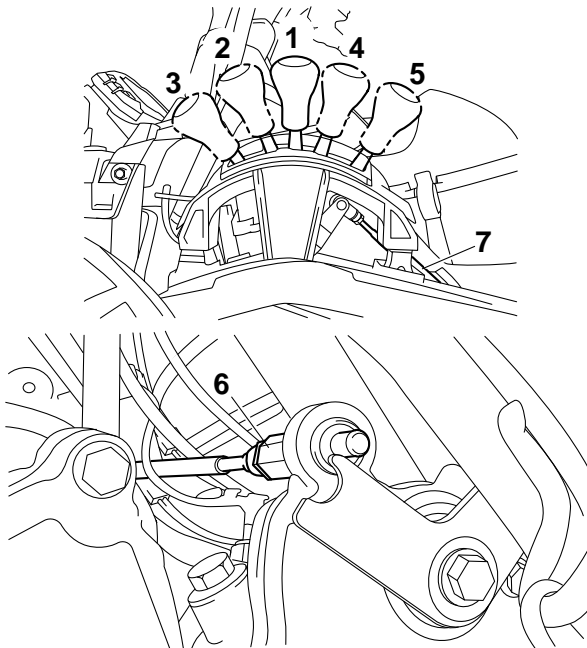

1. "N" (neutral)
2. "H" (high)
3. "L" (low)
4. "R" (reverse)
5. "P" (park)
6. Drive select lever shift control cable
7. Drive select lever shift rod

1. Adjust:

- Brake pedal free play
Refer to "ADJUSTING THE REAR DISC BRAKE" on page 3-19.

2. Remove:

- Left side panel
Refer to "GENERAL CHASSIS" on page 4-1.

3. Adjust:

- Drive select lever shift control cable
- Drive select lever shift rod

Drive select lever shift control cable:

- Make sure that the drive select lever is in "N" (neutral).
- Squeeze the brake lever 20 mm (0.79 in) "a", loosen the locknut "1", and then adjust the shift control cable "2" with the adjuster "3" so that the drive select lever can be shifted to "R" (reverse) from "N" (neutral), and to "P" (park) from "R" (reverse).

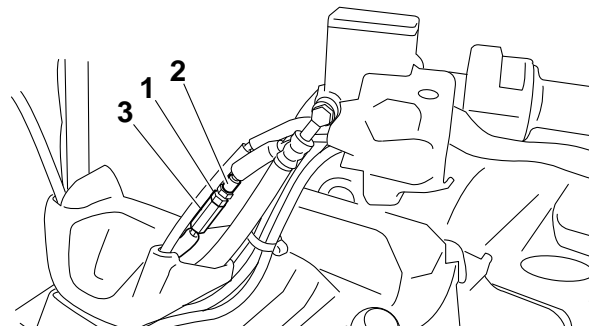
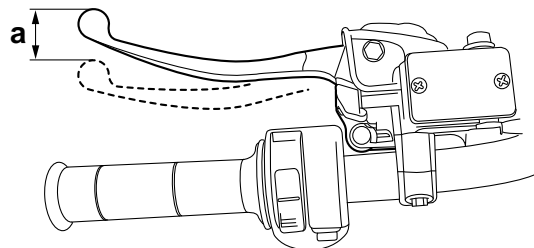

- Release the brake lever so that "a" is 0 mm (0 in), and then verify that the drive select lever cannot be shifted to "R" (reverse) from "N" (neutral), or to "P" (park) from "R" (reverse).
- If the operation of the drive select lever is incorrect, repeat steps (a) to (c).
- Tighten the locknut.

Drive select lever shift rod:

- Make sure the drive select lever and transmission are in "N" (neutral).
- Loosen both locknuts "1".
- Adjust the length "a" of the shift rod to 413 mm (16.3 in).

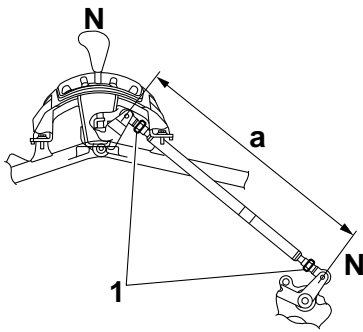

d. Tighten the locknuts.



Drive select lever shift rod locknut
7 Nm (0.7 m·kg, 5.1 ft·lb)

e. Start the engine, and then check that the drive select lever can be shifted to each shift position and that the appropriate indicator light comes on when the lever is in each position.

TIP

If the neutral indicator light does not come on when the drive select lever is in the “N” (neutral) position, stop the engine. Then, with the drive select lever in the “N” (neutral) position and without opening the throttle, start the engine and check that the neutral indicator light comes on.

f. Adjust the shift control cable again if necessary.



EAS21460

CHECKING THE FINAL GEAR OIL LEVEL

1. Place the vehicle on a level surface.
2. Remove:
 - Final gear oil level check bolt “1”
3. Check:
 - Final gear oil level
 - The final gear oil level should be up to the brim “2” of the hole.
 - Below the brim → Add the recommended final gear oil to the proper level.



Type
SAE 80 API GL-4 Hypoid gear oil

ECA28P1005

NOTICE

Take care not to allow foreign material to enter the final drive case.

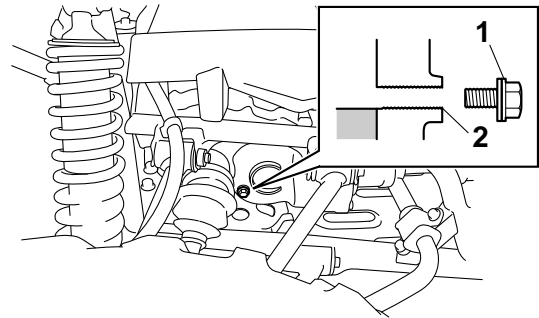

4. Install:

- Final gear oil level check bolt



Final gear oil level check bolt
10 Nm (1.0 m·kg, 7.2 ft·lb)

EAS21470

CHANGING THE FINAL GEAR OIL

1. Place the vehicle on a level surface.
2. Place a container under the final drive case.
3. Remove:
 - Final gear oil filler bolt “1”

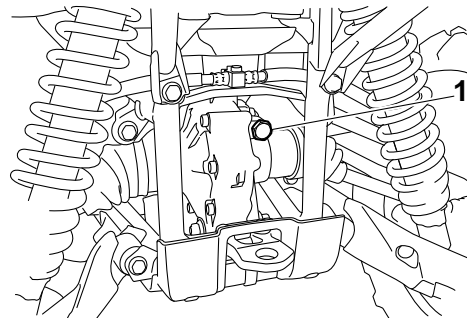

4. Remove:

- Final gear oil level check bolt
 - Final gear oil drain bolt “1”
- Completely drain the final drive case of its oil.

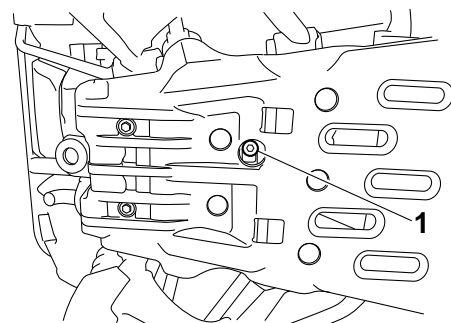

5. Check:

- Final gear oil drain bolt gasket
- Damage → Replace.

6. Install:

- Final gear oil drain bolt (with the gasket)



Final gear oil drain bolt
23 Nm (2.3 m·kg, 17 ft·lb)

7. Fill:

- Final drive case
 (with the specified amount of the recommended final gear oil)



Quantity (disassembled)
0.25 L (0.26 US qt, 0.22 Imp.qt)
Quantity
0.20 L (0.21 US qt, 0.18 Imp.qt)
Type
SAE 80 API GL-4 Hypoid gear oil

ECA28P1005

NOTICE

Take care not to allow foreign material to enter the final drive case.

8. Check:

- Oil level
 Refer to “CHECKING THE FINAL GEAR OIL LEVEL” on page 3-24.

9. Install:

- Final gear oil level check bolt
- Final gear oil filler bolt



Final gear oil level check bolt
10 Nm (1.0 m·kg, 7.2 ft·lb)
Final gear oil filler bolt
23 Nm (2.3 m·kg, 17 ft·lb)

EAS29250

CHECKING THE DIFFERENTIAL GEAR OIL LEVEL

1. Place the vehicle on a level surface.
2. Remove:
 - Differential gear oil filler bolt “1”
3. Check:
 - Differential gear oil level
 The differential gear oil level should be up to the brim “2” of the hole.
 Below the brim → Add the recommended differential gear oil to the proper level.



Type
SAE 80 API GL-4 Hypoid gear oil

ECA16170

NOTICE

Take care not to allow foreign material to enter the differential case.

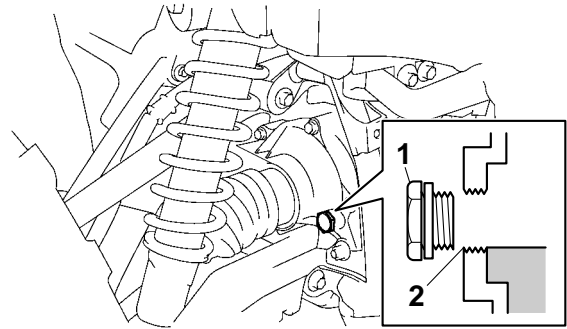

4. Install:

- Differential gear oil filler bolt



Differential gear oil filler bolt
23 Nm (2.3 m·kg, 17 ft·lb)

EAS29260

CHANGING THE DIFFERENTIAL GEAR OIL

1. Place the vehicle on a level surface.
2. Place a receptacle under the differential case.
3. Remove:
 - Differential gear oil filler bolt
 - Differential gear oil drain bolt “1”
 Completely drain the differential case of its oil.

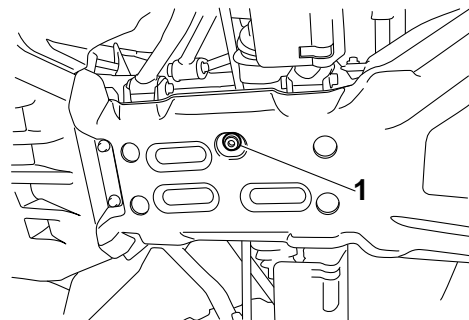

4. Check:

- Differential gear oil drain bolt gasket
 Damage → Replace.

5. Install:

- Differential gear oil drain bolt



Differential gear oil drain bolt
10 Nm (1.0 m·kg, 7.2 ft·lb)

6. Fill:

- Differential case
 (with the specified amount of the recommended differential gear oil)



Quantity (disassembled)
0.23 L (0.24 US qt, 0.20 Imp.qt)
Quantity
0.22 L (0.23 US qt, 0.19 Imp.qt)
Type
SAE 80 API GL-4 Hypoid gear
oil

ECA16170

NOTICE

Take care not to allow foreign material to enter the differential case.

TIP

If gear oil is filled to the brim of the oil filler hole, oil may start leaking from the differential case breather hose. Therefore, check the quantity of the oil, not its level.

7. Check:

- Oil level
Refer to "CHECKING THE DIFFERENTIAL GEAR OIL LEVEL" on page 3-25.

8. Install:

- Differential gear oil filler bolt



Differential gear oil filler bolt
23 Nm (2.3 m·kg, 17 ft·lb)

EAS29270

CHECKING THE CONSTANT VELOCITY SHAFT ASSEMBLY DUST BOOTS

1. Check:

- Dust boots "1"
Damage → Replace.
Refer to "FRONT CONSTANT VELOCITY SHAFT ASSEMBLIES, DIFFERENTIAL ASSEMBLY AND FRONT DRIVE SHAFT" on page 8-3 and "REAR CONSTANT VELOCITY SHAFT ASSEMBLIES, FINAL DRIVE ASSEMBLY AND REAR DRIVE SHAFT" on page 8-15.

A

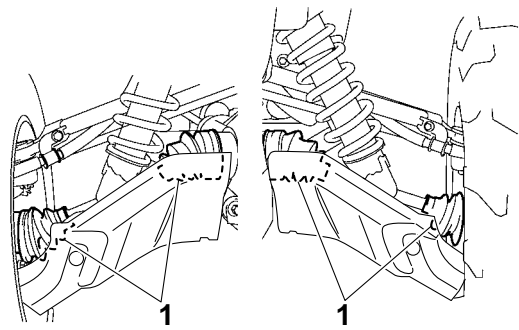

B

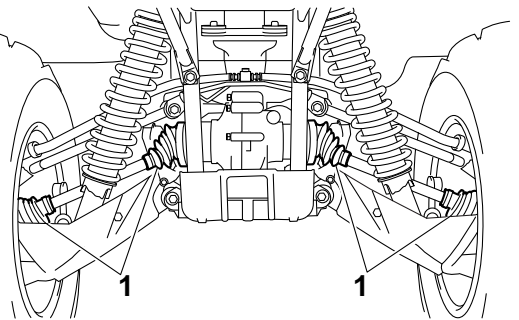

A. Front

B. Rear

EAS29280

CHECKING THE STEERING SYSTEM

1. Place the vehicle on a level surface.

2. Check:

- Steering assembly bushings
Move the handlebar up and down, and back and forth.
Excessive play → Replace the steering stem bushings.

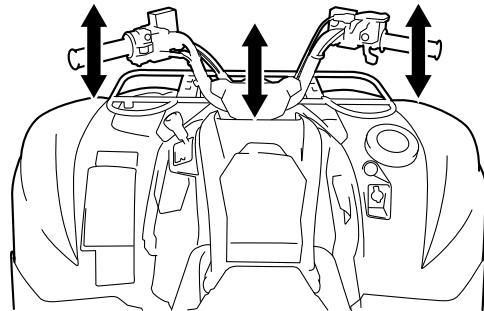

3. Check:

- Tie-rod ends
Free play → Replace the tie-rod end.

- a. Turn the handlebar left until it stops.
- b. Move the handlebar slightly to the right and left.
- c. Check for play in the tie-rod ends.
- d. Turn the handlebar right until it stops.
- e. Move the handlebar slightly to the left and right.
- f. Check for play in the tie-rod ends.

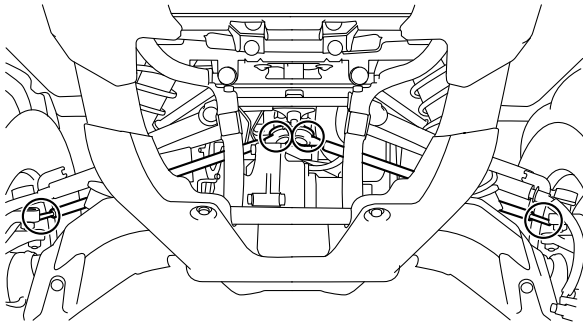

4. Raise the front end of the vehicle so that there is no weight on the front wheels.
5. Check:
 - Ball joints and wheel bearings
 Move the wheels laterally back and forth. Excessive free play → Replace the front arms (upper and lower) and/or wheel bearings.

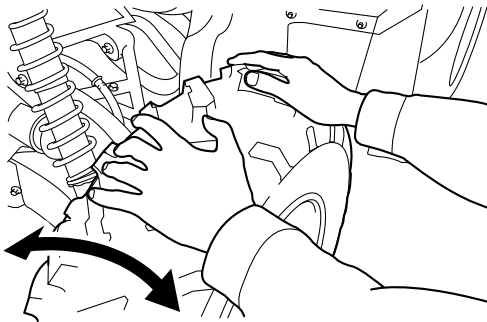

6. Measure: (for EPS models)
 - Steering tension
 Above specification → Adjust.

	Steering tension 50 N (5.0 kgf) (for EPS models)
--	---



- a. Set the main switch to "OFF".
- b. Place the vehicle on a suitable stand so that the front wheels are elevated.
- c. Point the front wheels straight ahead.
- d. Hold the belt tension gauge "1" at a 90° angle to the handlebar, push the gauge against the handlebar, and then record the measurement when the handlebar starts to turn.

	Belt tension gauge 90890-03170 Rear drive belt tension gauge YM-03170
--	--

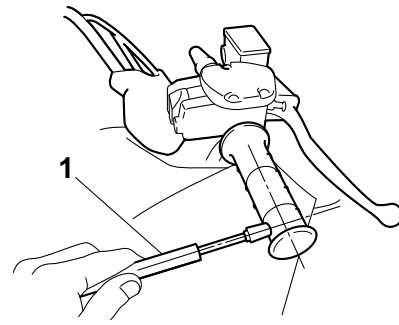

7. Adjust: (for EPS models)
 - Steering tension



- a. Remove the electrical components tray. Refer to "GENERAL CHASSIS" on page 4-1.
- b. Loosen the steering stem bracket bolts "1" and steering stem pinch bolt "2" completely.

TIP

After loosening the bolts, be sure to check that the steering stem moves smoothly on the serrations of the shaft of the EPS unit.

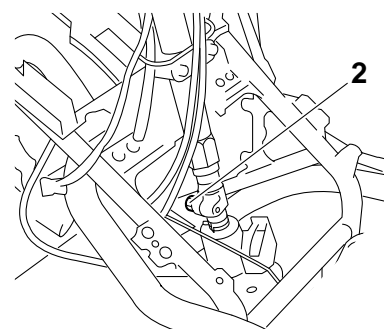
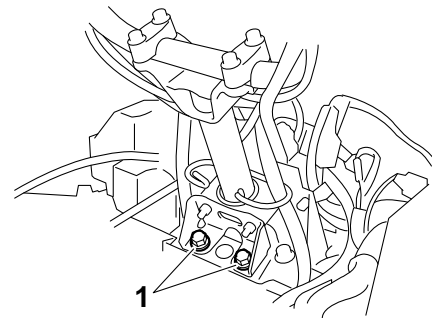

- c. Tighten the steering stem bracket bolts to specification.

	Steering stem bracket bolt 51 Nm (5.1 m·kg, 37 ft·lb) LOCTITE®
--	---

- d. Tighten the steering stem pinch bolt to specification.



Steering stem pinch bolt
35 Nm (3.5 m·kg, 25 ft·lb)
LOCTITE®

- e. Measure the steering tension again.
- f. Repeat the above procedure until the steering tension is below specification.



Steering tension
50 N (5.0 kgf) (for EPS models)

- g. Install the electrical components tray. Refer to “GENERAL CHASSIS” on page 4-1.



EAS29290

ADJUSTING THE TOE-IN

1. Place the vehicle on a level surface.
2. Measure:
 - Toe-in
 Out of specification → Adjust.



Toe-in (with tire touching the ground)
0.0–10.0 mm (0.00–0.39 in)

TIP

Before measuring the toe-in, make sure that the tire pressure is correct.



- a. Mark both front tire tread centers.
- b. Face the handlebar straight ahead.
- c. Measure the width “A” between the marks.
- d. Rotate the front tires 180° until the marks are exactly opposite one another.
- e. Measure the width “B” between the marks.
- f. Calculate the toe-in using the formula given below.

$$\text{Toe-in} = \text{“B”} - \text{“A”}$$

- g. If the toe-in is incorrect, adjust it.

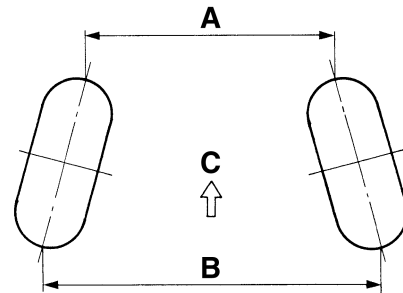
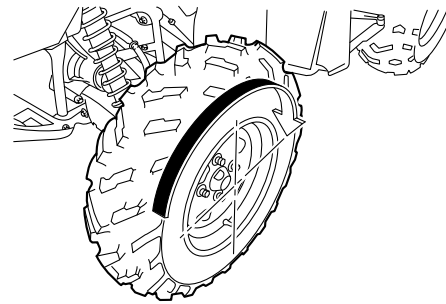

C. Forward



3. Adjust:
 - Toe-in

EWA14910

WARNING

- Be sure that both tie-rods are turned the same amount. If not, the vehicle will drift right or left even though the handlebar is positioned straight. This may lead to mis-handling and an accident.
- After setting the toe-in to specification, run the vehicle slowly for some distance with both hands lightly holding the handlebar and check that the handlebar responds correctly. If not, turn either the right or left tie-rod within the toe-in specification.



- a. Mark both tie-rod ends.
This reference point will be needed during adjustment.
- b. Loosen the locknuts (tie-rod end) “1” of both tie-rods.
- c. The same number of turns should be given to both the right and left tie-rods “2” until the specified toe-in is obtained. This is to keep the length of the tie-rods the same.

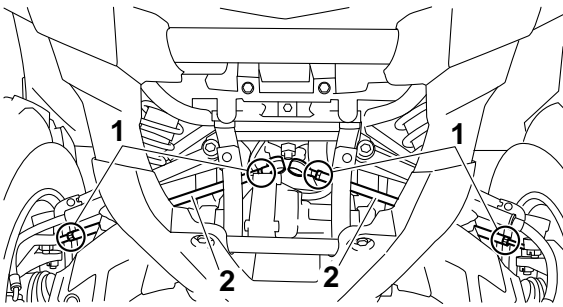

d. Tighten the rod end locknuts of both tie-rod.

	<p>Tie-rod end locknut 15 Nm (1.5 m·kg, 11 ft·lb)</p>
---	--

TIP

Adjust the tie-rod ends so that “A” and “B” are equal.

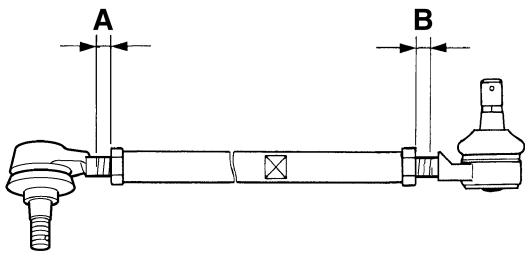

EAS29300

CHECKING THE FRONT SHOCK ABSORBER ASSEMBLIES

The following procedure applies to both of the front shock absorber assemblies.

1. Place the vehicle on a level surface.
2. Check:
 - Damper rod
 Bends/damage → Replace the front shock absorber assembly.
 Refer to “FRONT ARMS AND FRONT SHOCK ABSORBER ASSEMBLIES” on page 4-60.
 - Oil leakage
 Excessive oil leakage → Replace the front shock absorber assembly.
 Refer to “FRONT ARMS AND FRONT SHOCK ABSORBER ASSEMBLIES” on page 4-60.
 - Spring
 Fatigue → Replace the front shock absorber assembly.

Refer to “FRONT ARMS AND FRONT SHOCK ABSORBER ASSEMBLIES” on page 4-60.

3. Check:

- Operation
 Pump the front shock absorber assembly up and down several times.
 Rough operation → Replace front shock absorber assembly.
 Refer to “FRONT ARMS AND FRONT SHOCK ABSORBER ASSEMBLIES” on page 4-60.

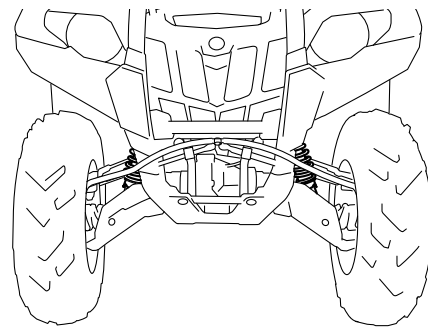

EAS29310

ADJUSTING THE FRONT SHOCK ABSORBER ASSEMBLIES

The following procedure applies to both of the front shock absorber assemblies.

EWA14920

WARNING

Always adjust the spring preload for both front shock absorber assemblies to the same setting. Uneven adjustment can cause poor handling and loss of stability.

1. Adjust:

- Spring preload
 Turn the adjuster “1” in direction “a” or “b”.

	<p>Ring nut wrench 90890-01268 Spanner wrench YU-01268</p>
---	---

<p>Direction “a” Spring preload is increased (suspension is harder). Direction “b” Spring preload is decreased (suspension is softer).</p>



Spring preload adjusting positions
Minimum
 1
Standard
 2
Maximum
 5

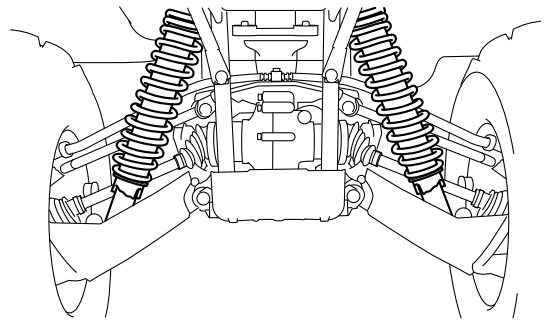

EAS29330

ADJUSTING THE REAR SHOCK ABSORBER ASSEMBLIES

The following procedure applies to both of the rear shock absorber assemblies.

EWA14930

WARNING

Always adjust the spring preload for both rear shock absorber assemblies to the same setting. Uneven adjustment can cause poor handling and loss of stability.

EAS29320

CHECKING THE REAR SHOCK ABSORBER ASSEMBLIES

The following procedure applies to both of the rear shock absorber assemblies.

1. Place the vehicle on a level surface.
2. Check:
 - Damper rod
Bends/damage → Replace the rear shock absorber assembly.
Refer to “REAR ARMS AND REAR SHOCK ABSORBER ASSEMBLIES” on page 4-67.
 - Oil leakage
Excessive oil leakage → Replace the rear shock absorber assembly.
Refer to “REAR ARMS AND REAR SHOCK ABSORBER ASSEMBLIES” on page 4-67.
 - Spring
Fatigue → Replace the rear shock absorber assembly.
Refer to “REAR ARMS AND REAR SHOCK ABSORBER ASSEMBLIES” on page 4-67.
3. Check:
 - Operation
Pump the rear shock absorber assembly up and down several times.
Rough operation → Replace rear shock absorber assembly.
Refer to “REAR ARMS AND REAR SHOCK ABSORBER ASSEMBLIES” on page 4-67.

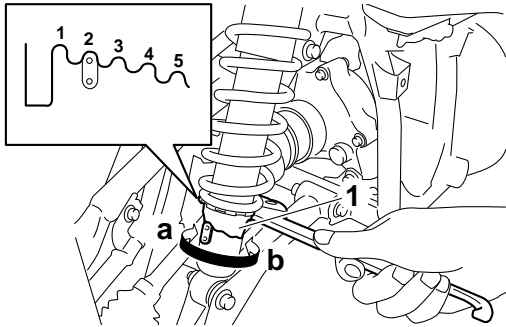

1. Adjust:

- Spring preload
Turn the adjuster “1” in direction “a” or “b”.



Ring nut wrench
 90890-01268
Spanner wrench
 YU-01268

Direction “a”
Spring preload is increased (suspension is harder).
Direction “b”
Spring preload is decreased (suspension is softer).



Spring preload adjusting positions
Minimum
 1
Standard
 2
Maximum
 5

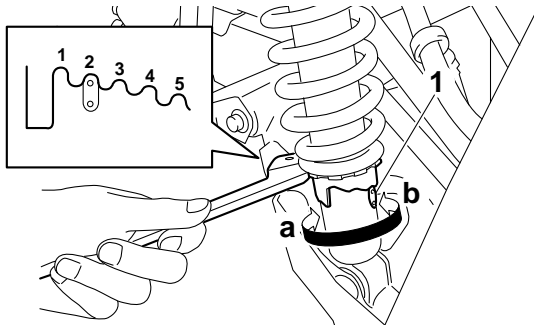

EAS29340

CHECKING THE TIRES

The following procedure applies to all of the tires.

EWA14940



WARNING

This model is equipped with low-pressure tires. It is important that they be inflated correctly and maintained at the proper pressures.

Tire characteristics

EWA14950



WARNING

Tire characteristics influence the handling of vehicles. The tires listed below have been approved by Yamaha Motor Co., Ltd. for this model. If other tire combinations are used, they can adversely affect your vehicle's handling characteristics and are therefore not recommended.



Front tire

Type

Tubeless

Size

AT25 × 8–12

Manufacturer/model

MAXXIS/MU19A (for CDN and Europe)

CHENG SHIN/C828 (for Oceania)

Rear tire

Type

Tubeless

Size

AT25 × 10–12

Manufacturer/model

MAXXIS/MU20A (for CDN and Europe)

CHENG SHIN/C828 (for Oceania)

Tire pressure

EWA14960



WARNING

- Tire pressure below the minimum specification could cause the tire to dislodge from the rim under severe riding conditions.
- Use no more than the following pressures when seating the tire beads.

Front

250 kPa (2.5 kgf/cm², 36 psi)

Rear

250 kPa (2.5 kgf/cm², 36 psi)

Higher pressures and fast inflation may cause a tire to burst. Inflate the tires very slowly and carefully.



Tire air pressure (measured on cold tires)

Recommended

Front

35 kPa (0.35 kgf/cm², 5.0 psi)

Rear

30 kPa (0.30 kgf/cm², 4.4 psi)

Minimum

Front

32 kPa (0.32 kgf/cm², 4.6 psi)

Rear

27 kPa (0.27 kgf/cm², 4.0 psi)

Maximum loading limit

EWA14970



WARNING

Be extra careful of the vehicle balance and stability when towing a trailer.



Maximum loading limit

220.0 kg (485 lb)

(Total weight of rider, cargo, accessories, and tongue)

Front carrier

45.0 kg (99 lb)

Rear carrier

85.0 kg (187 lb)

Front storage compartment

0.5 kg (1 lb)

Rear storage compartment

2.0 kg (4 lb)

Trailer hitch

Pulling load (total weight of trailer and cargo)

5880 N (600 kgf, 1322 lbf)

Tongue weight (vertical weight on trailer hitch point)

147 N (15 kgf, 33 lbf)

- Measure:
 - Tire pressure
 Out of specification → Adjust.



Tire air pressure (measured on cold tires)

Recommended

Front
35 kPa (0.35 kgf/cm², 5.0 psi)

Rear
30 kPa (0.30 kgf/cm², 4.4 psi)

Minimum

Front
32 kPa (0.32 kgf/cm², 4.6 psi)

Rear
27 kPa (0.27 kgf/cm², 4.0 psi)

- TIP**
- The low-pressure tire gauge “1” is included as standard equipment.
 - In order to ensure an accurate reading, make sure that the gauge is clean before use.

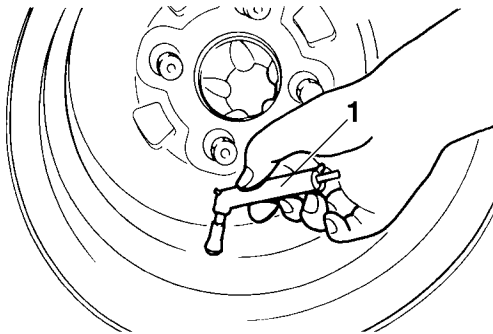

- EWA14980
- WARNING**
- Uneven or improper tire pressure may adversely affect the handling of this vehicle and may cause loss of control.
- Maintain proper tire pressures.
 - Set tire pressures when the tires are cold.
 - Tire pressures must be equal in both front tires and equal in both rear tires.

- Check:
 - Tire surfaces
 Wear/damage → Replace.



Wear limit (front)
3.0 mm (0.12 in)

Wear limit (rear)
3.0 mm (0.12 in)

EWA28P1006

WARNING

It is dangerous to ride with a worn-out tire. When the tire tread reaches the wear limit “a”, replace the tire immediately.

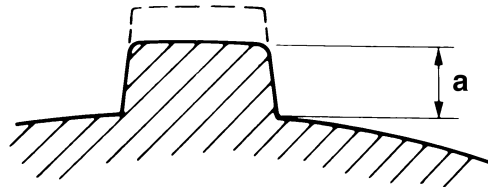

- TIP**
- The arrow mark “1” on the tire must point in the direction of wheel rotation.

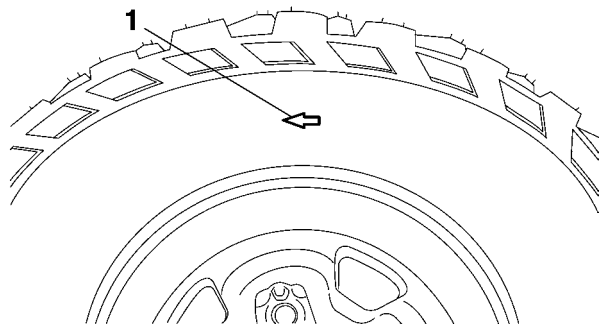

EAS29350

CHECKING THE WHEELS

The following procedure applies to all of the wheels.

- Check:
 - Wheel “1”
 Damage/bends → Replace.

EWA14990

WARNING

- Never attempt even small repairs to the wheel.
- Ride conservatively after installing a tire to allow it to seat itself properly on the rim.

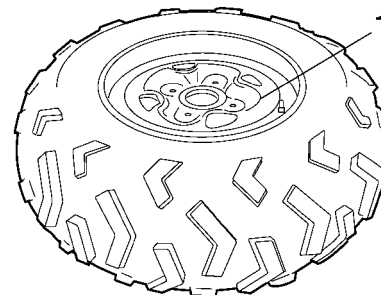

EAS21690

CHECKING AND LUBRICATING THE CABLES

The following procedure applies to all of the inner and outer cables.

EWA13270



Damaged outer cable may cause the cable to corrode and interfere with its movement. Replace damaged outer cable and inner cables as soon as possible.

1. Check:
 - Outer cable
Damage → Replace.
2. Check:
 - Cable operation
Rough movement → Lubricate.



Recommended lubricant
Engine oil or a suitable cable lubricant

TIP

Hold the cable end upright and pour a few drops of lubricant into the cable sheath or use a suitable lubricating device.

3. Apply:
 - Lithium-soap-based grease
(onto end of the cable)

EAS21700

LUBRICATING THE LEVERS

Lubricate the pivoting point and metal-to-metal moving parts of the levers.



Recommended lubricant
Silicone grease

EAS21710

LUBRICATING THE PEDAL

Lubricate the pivoting point and metal-to-metal moving parts of the pedal.



Recommended lubricant
Lithium-soap-based grease

EAS21750

ELECTRICAL SYSTEM

EAS21760

CHECKING AND CHARGING THE BATTERY

Refer to "ELECTRICAL COMPONENTS" on page 9-75.

EAS21770

CHECKING THE FUSES

Refer to "ELECTRICAL COMPONENTS" on page 9-75.

EAS21790

REPLACING THE HEADLIGHT BULBS

The following procedure applies to both of the headlight bulbs.

1. Remove:
 - Cover at the rear of the headlight "1"

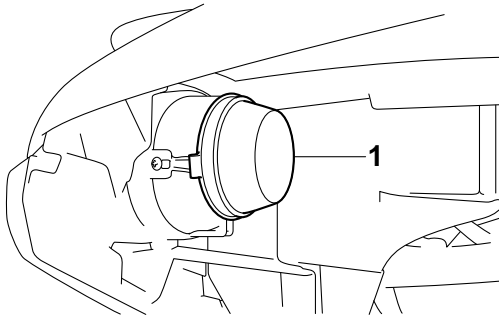

2. Remove:
 - Headlight bulb cover "1"

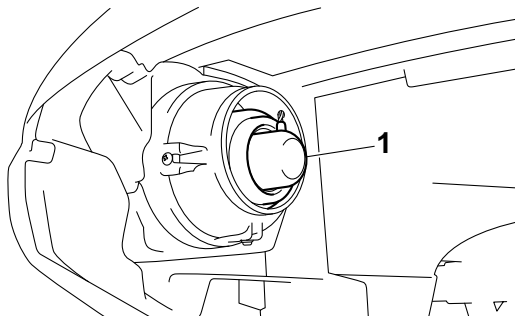

3. Disconnect:
 - Headlight coupler "1"

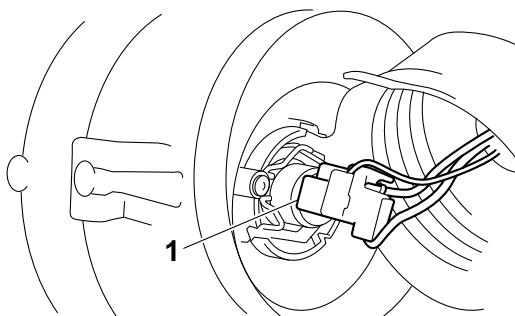

4. Remove:
 - Headlight bulb holder "1"

- Headlight bulb "2"

EWA13320

WARNING

Since the headlight bulb gets extremely hot, keep flammable products and your hands away from the bulb until it has cooled down.

TIP

Unhook the headlight bulb holder, and then remove the defective bulb.

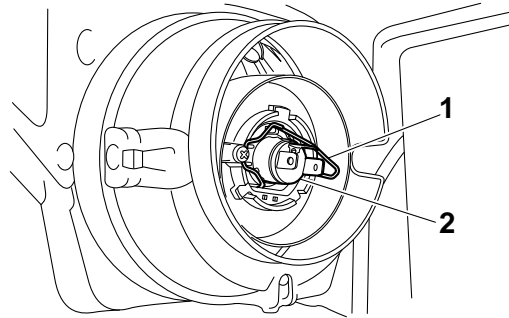

5. Install:
 - Headlight bulb **New**
 - Secure the new headlight bulb with the headlight bulb holder.

ECA13690

NOTICE

Avoid touching the glass part of the headlight bulb to keep it free from oil, otherwise the transparency of the glass, the life of the bulb and the luminous flux will be adversely affected. If the headlight bulb gets soiled, thoroughly clean it with a cloth moistened with alcohol or lacquer thinner.

6. Install:
 - Headlight bulb holder
7. Connect:
 - Headlight coupler
8. Install:
 - Headlight bulb cover
 - Cover at the rear of the headlight

EAS21810

ADJUSTING THE HEADLIGHT BEAMS

The following procedure applies to both of the headlights.

1. Adjust:
 - Headlight beam (vertically)

- a. Turn the adjusting screw "1" in direction "a" or "b".

Direction "a"
Headlight beam is raised.
Direction "b"
Headlight beam is lowered.

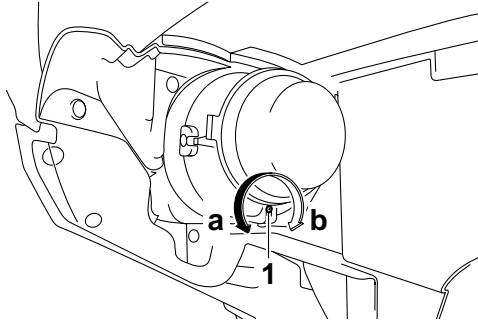

CHASSIS

GENERAL CHASSIS	4-1
INSTALLING THE REAR FENDER.....	4-6
INSTALLING THE FOOTREST BOARDS.....	4-12
FRONT WHEELS	4-14
REMOVING THE FRONT WHEELS	4-15
REMOVING THE FRONT WHEEL HUBS.....	4-15
CHECKING THE FRONT WHEELS.....	4-15
CHECKING THE FRONT WHEEL HUBS	4-15
INSTALLING THE FRONT BRAKE DISCS.....	4-16
INSTALLING THE FRONT WHEEL HUBS	4-16
INSTALLING THE FRONT WHEELS.....	4-16
REAR WHEELS	4-18
REMOVING THE REAR WHEELS.....	4-19
REMOVING THE REAR WHEEL HUBS	4-19
CHECKING THE REAR WHEELS	4-19
CHECKING THE REAR WHEEL HUBS.....	4-19
INSTALLING THE REAR BRAKE DISCS	4-19
INSTALLING THE REAR WHEEL HUBS.....	4-19
INSTALLING THE REAR WHEELS	4-20
FRONT BRAKE	4-21
INTRODUCTION	4-26
CHECKING THE FRONT BRAKE DISCS.....	4-26
REPLACING THE FRONT BRAKE PADS	4-27
DISASSEMBLING THE FRONT BRAKE CALIPERS.....	4-27
CHECKING THE FRONT BRAKE CALIPERS	4-28
ASSEMBLING THE FRONT BRAKE CALIPERS.....	4-28
INSTALLING THE FRONT BRAKE CALIPERS	4-29
CHECKING THE FRONT BRAKE MASTER CYLINDER.....	4-29
ASSEMBLING THE FRONT BRAKE MASTER CYLINDER	4-30
INSTALLING THE FRONT BRAKE MASTER CYLINDER.....	4-30
REAR BRAKE	4-32
INTRODUCTION	4-38
CHECKING THE REAR BRAKE DISCS	4-38
REPLACING THE REAR BRAKE PADS.....	4-38
REMOVING THE REAR BRAKE MASTER CYLINDER	4-39
DISASSEMBLING THE REAR BRAKE CALIPERS	4-39
CHECKING THE REAR BRAKE CALIPERS	4-40
ASSEMBLING THE REAR BRAKE CALIPERS	4-40
INSTALLING THE REAR BRAKE CALIPERS	4-40
CHECKING THE REAR BRAKE MASTER CYLINDER	4-41
ASSEMBLING THE REAR BRAKE MASTER CYLINDER.....	4-41
INSTALLING THE REAR BRAKE MASTER CYLINDER.....	4-41

HANDLEBAR	4-44
REMOVING THE HANDLEBAR	4-46
CHECKING THE HANDLEBAR	4-46
INSTALLING THE HANDLEBAR	4-46
STEERING STEM	4-49
REMOVING THE BEARING RETAINER (except for EPS models)	4-53
CHECKING THE STEERING STEM	4-53
INSTALLING THE STEERING STEM (except for EPS models)	4-53
INSTALLING THE STEERING STEM (for EPS models)	4-54
INSTALLING THE PITMAN ARM (except for EPS models)	4-55
INSTALLING THE PITMAN ARM (for EPS models)	4-55
TIE-RODS AND STEERING KNUCKLES	4-56
REMOVING THE STEERING KNUCKLES	4-57
CHECKING THE TIE-RODS	4-57
CHECKING THE STEERING KNUCKLES AND FRONT WHEEL BEARINGS	4-57
CHECKING THE STEERING KNUCKLE BALL JOINTS	4-57
INSTALLING THE TIE-RODS	4-59
INSTALLING THE FRONT ARM PROTECTORS	4-59
FRONT ARMS AND FRONT SHOCK ABSORBER ASSEMBLIES	4-60
CHECKING THE FRONT ARMS	4-62
CHECKING THE FRONT SHOCK ABSORBER ASSEMBLIES	4-62
CHECKING THE FRONT ARM BALL JOINTS	4-62
INSTALLING THE FRONT ARMS AND FRONT SHOCK ABSORBER ASSEMBLIES	4-63
INSTALLING THE FRONT ARM PROTECTORS	4-64
REAR KNUCKLES AND STABILIZER	4-65
CHECKING THE REAR KNUCKLES AND REAR WHEEL BEARINGS	4-66
CHECKING THE STABILIZER	4-66
INSTALLING THE REAR ARM PROTECTORS	4-66
REAR ARMS AND REAR SHOCK ABSORBER ASSEMBLIES	4-67
CHECKING THE REAR ARMS	4-68
CHECKING THE REAR SHOCK ABSORBER ASSEMBLIES	4-68
INSTALLING THE REAR ARMS AND REAR SHOCK ABSORBER ASSEMBLIES	4-68

EAS21830

GENERAL CHASSIS

Removing the engine skid plates

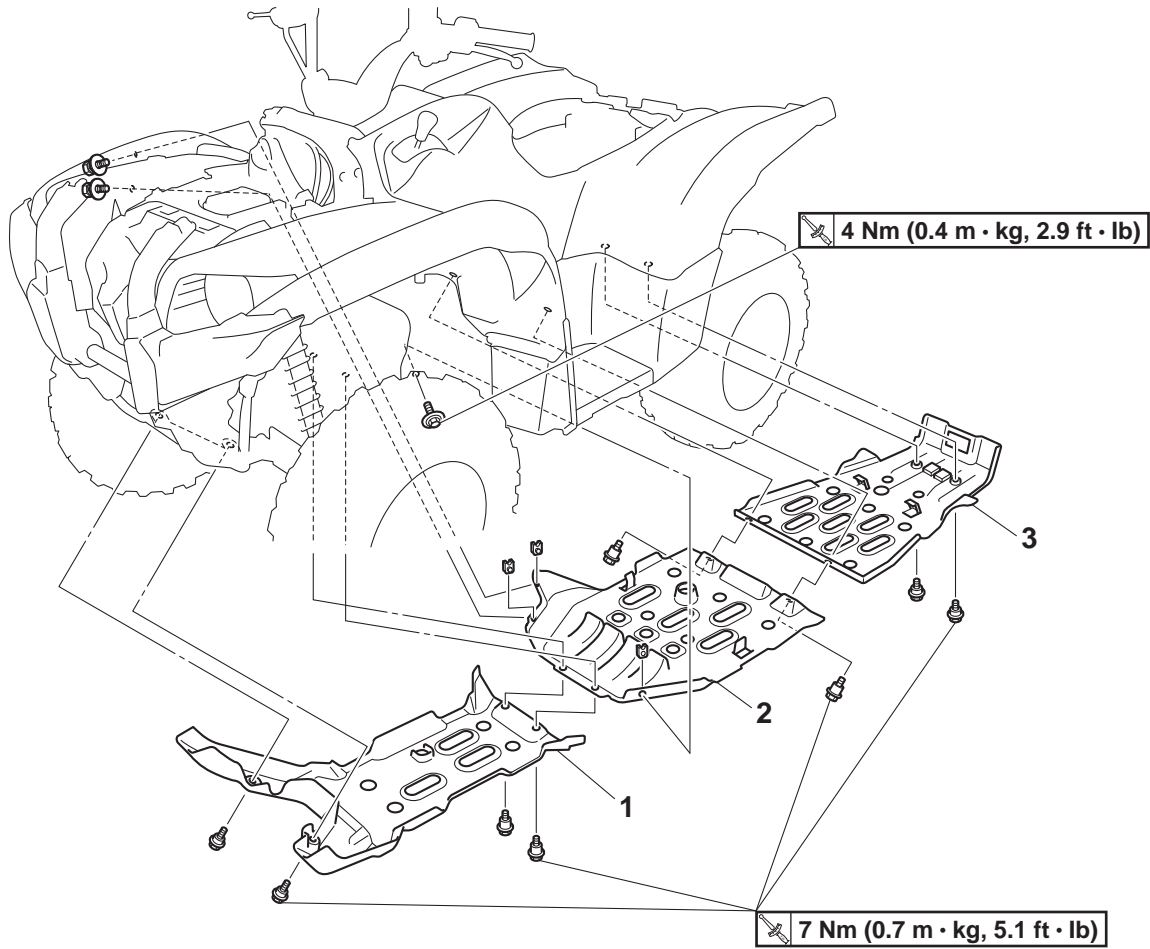

Order	Job/Parts to remove	Q'ty	Remarks
1	Front engine skid plate	1	
2	Center engine skid plate	1	
3	Rear engine skid plate	1	
			For installation, reverse the removal procedure.

GENERAL CHASSIS

Removing the seat and side panels

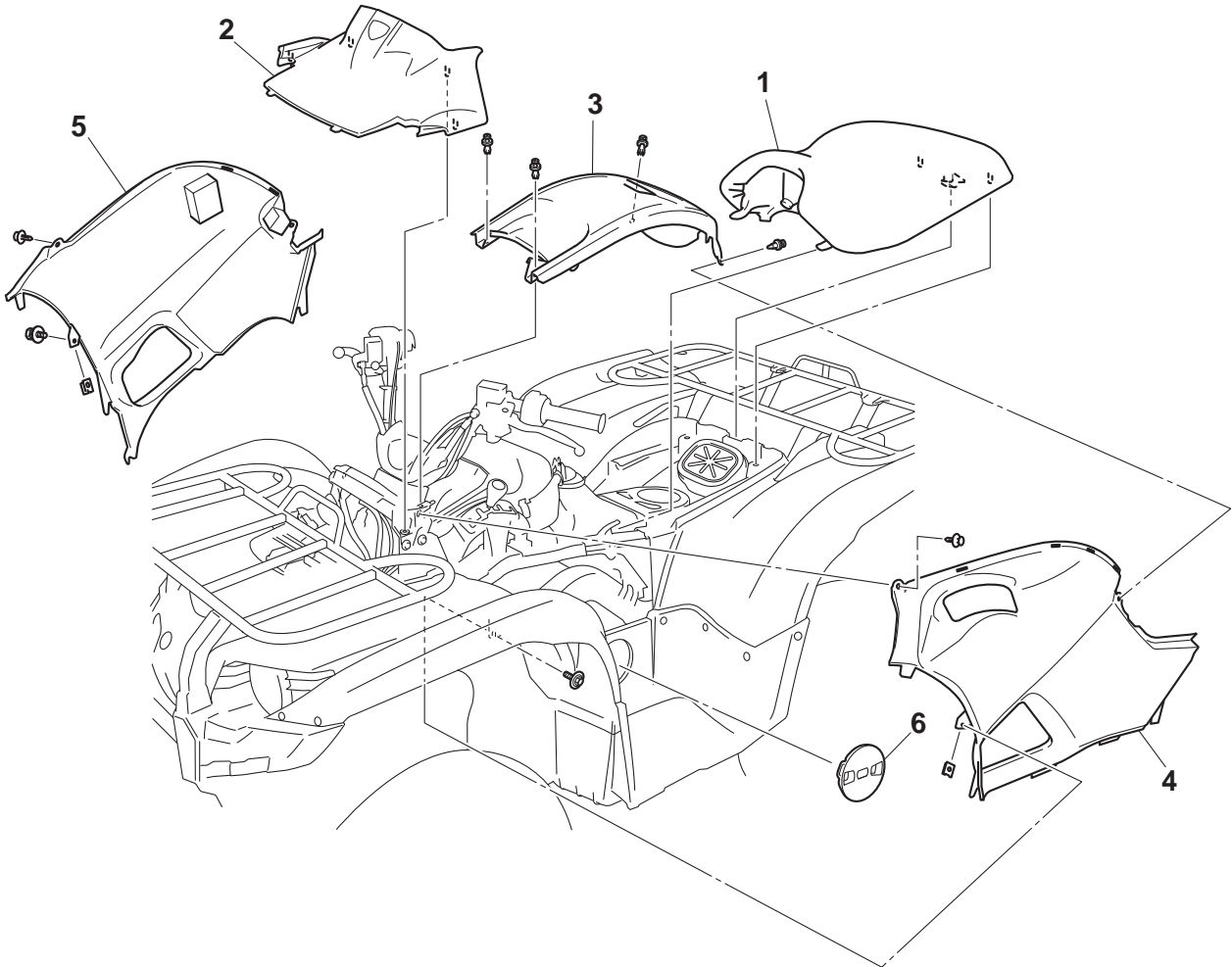

Order	Job/Parts to remove	Q'ty	Remarks
1	Seat	1	TIP _____ Pull up the seat lock lever, then pull up on the rear of the seat.
2	Battery cover	1	
3	Fuel tank cover	1	
4	Left side panel	1	
5	Right side panel	1	
6	Dipstick accessing cover	1	
			For installation, reverse the removal procedure.

GENERAL CHASSIS

Removing the front carrier and front guard

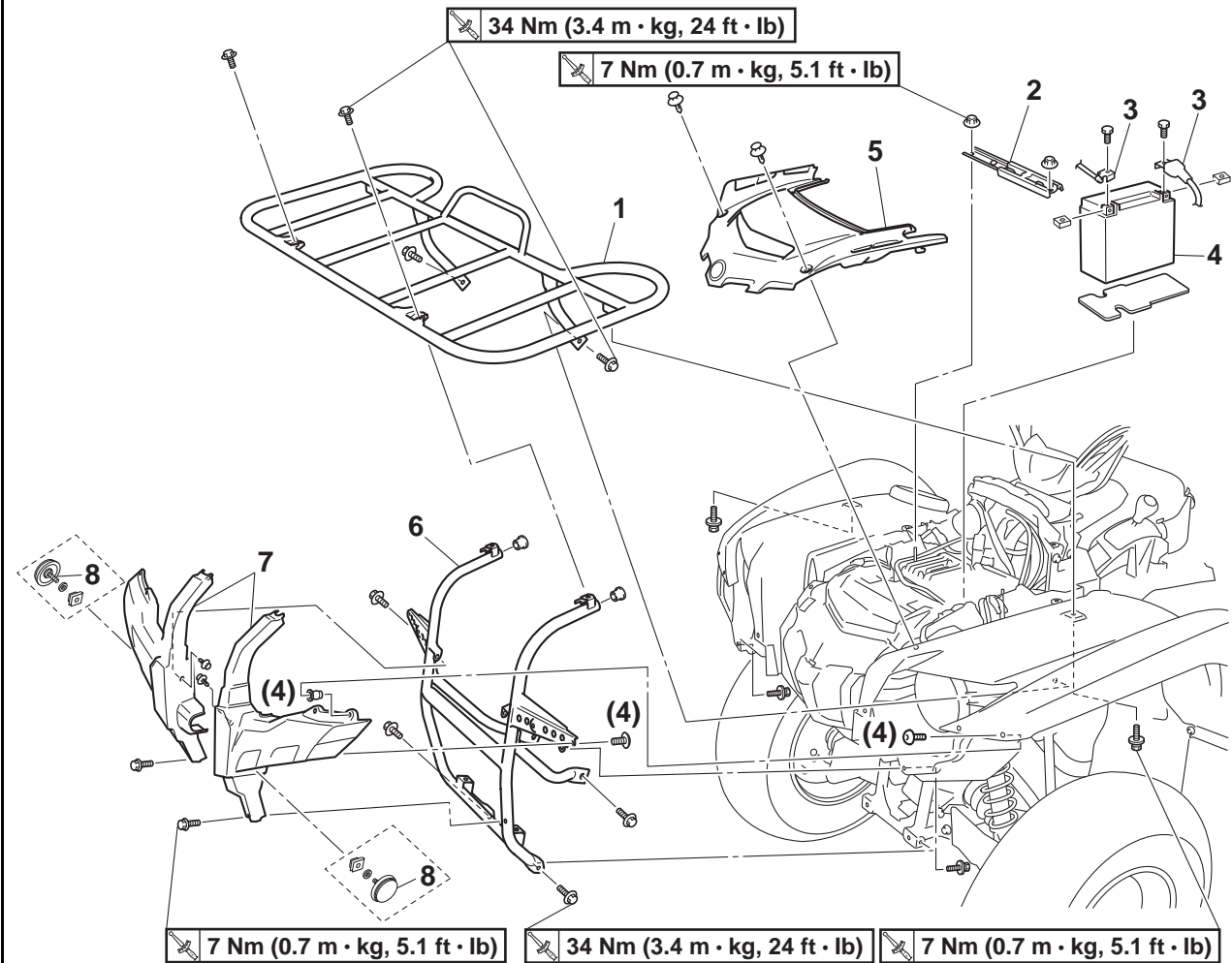

Order	Job/Parts to remove	Q'ty	Remarks
	Front engine skid plate		Refer to "Removing the engine skid plates".
1	Front carrier	1	
2	Battery holding bracket	1	
3	Battery lead	2	Disconnect. ECA28P1013 NOTICE _____ First disconnect the negative battery lead, then disconnect the positive lead.
4	Battery	1	
5	Upper panel	1	
6	Front guard	1	
7	Front guard cover	2	
8	Front reflector	2	For CDN
			For installation, reverse the removal procedure.

Removing the front fenders and front grill

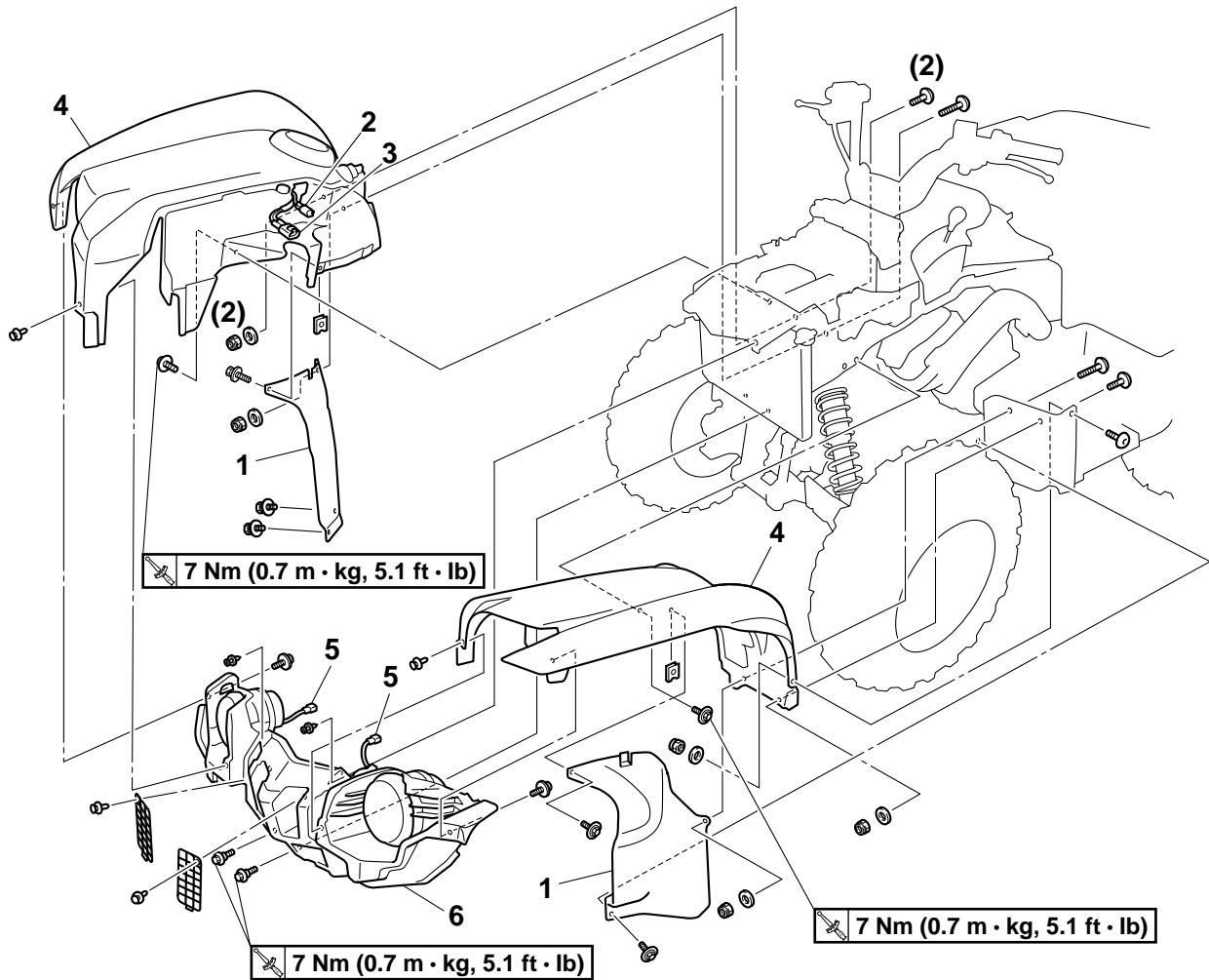

Order	Job/Parts to remove	Q'ty	Remarks
	Seat/Side panels		Refer to "Removing the seat and side panels".
	Front carrier/Front guard		Refer to "Removing the front carrier and front guard".
1	Front fender inner panel	2	
2	Auxiliary DC jack coupler	1	Disconnect.
3	Main switch coupler	1	Disconnect.
4	Front fender	2	
5	Headlight coupler	2	Disconnect.
6	Front grill	1	
			For installation, reverse the removal procedure.

GENERAL CHASSIS

Removing the rear carrier and rear fender

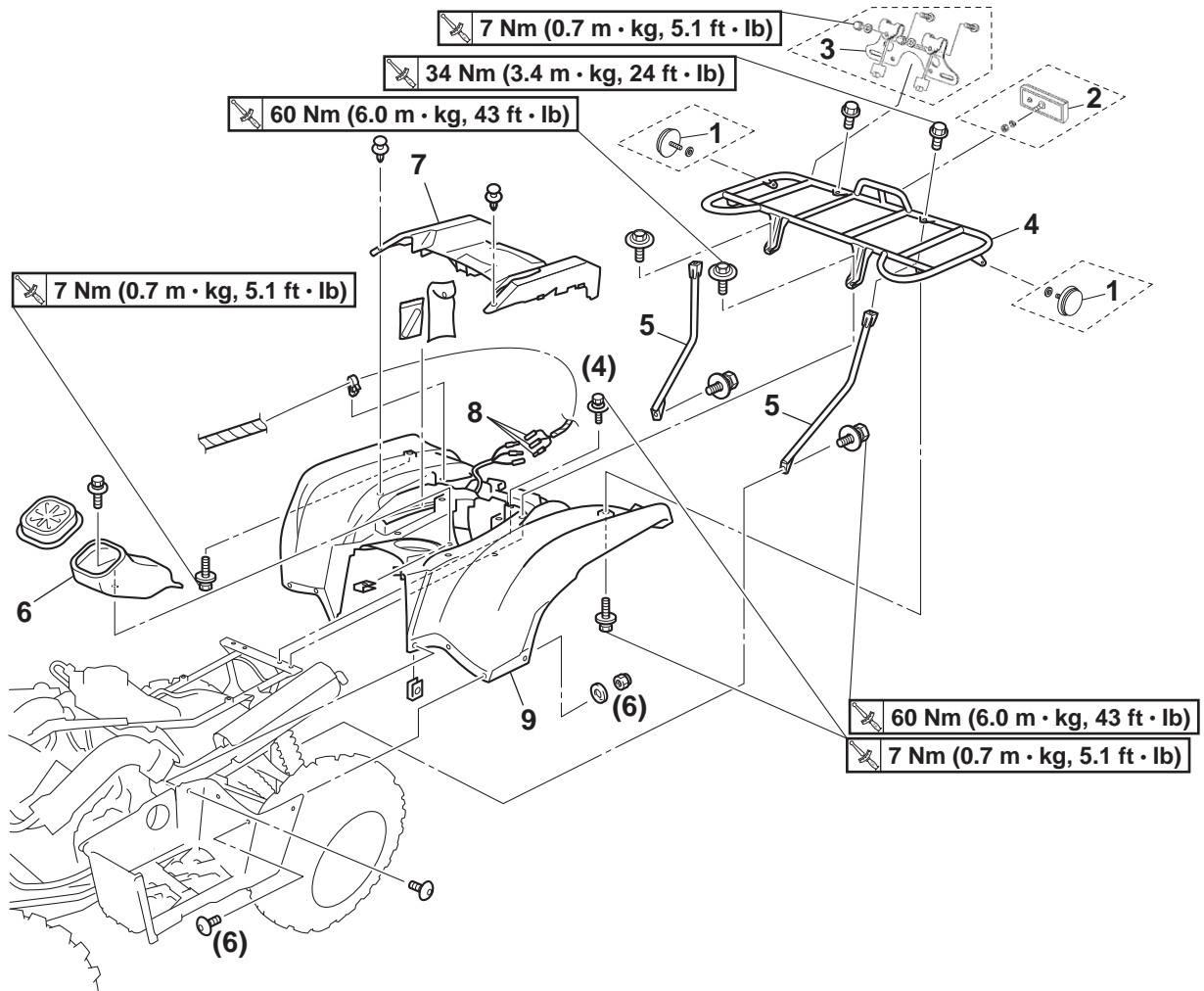

Order	Job/Parts to remove	Q'ty	Remarks
	Seat/Side panels		Refer to "Removing the seat and side panels".
1	Rear reflector	2	for CDN
2	Rear reflector	1	for CDN and Europe
3	License plate bracket	1	for CDN
4	Rear carrier	1	
5	Rear carrier bracket	2	
6	Storage compartment	1	
7	Tail/brake light cover	1	
8	Tail/brake light connector	3	Disconnect.
9	Rear fender	1	
			For installation, reverse the removal procedure.

EAS28P1002

INSTALLING THE REAR FENDER

1. Install:

- Rear fender



Rear fender bolt
7 Nm (0.7 m·kg, 5.1 ft·lb)

TIP

The bolts may be tightened to the specified torque in any tightening sequence. However, install the front bolts "1" and tighten them temporarily before installing the rear bolts "2".

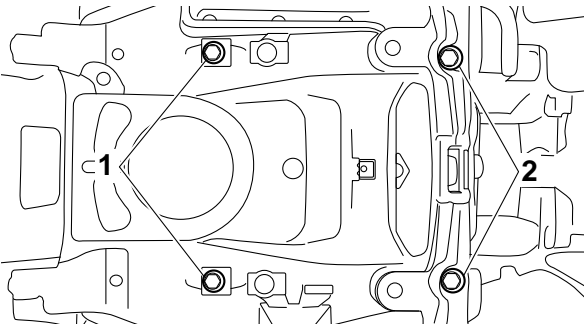

Removing the electrical components tray 1/2

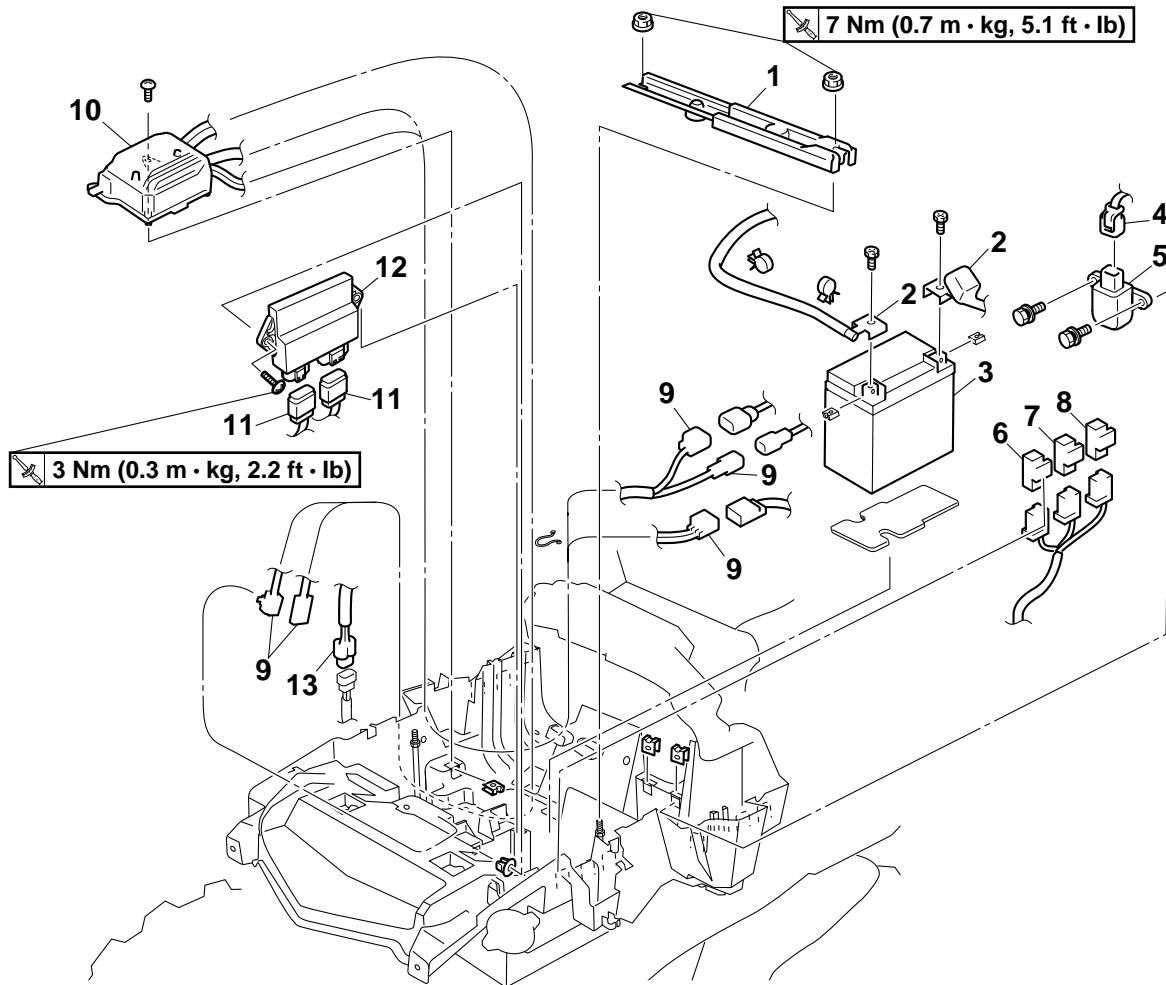

Order	Job/Parts to remove	Q'ty	Remarks
	Front fender/Front grill		Refer to "Removing the front fenders and front grill".
1	Battery holding bracket	1	
2	Battery lead	2	Disconnect. ECA28P1013 NOTICE _____ First disconnect the negative battery lead, then disconnect the positive lead.
3	Battery	1	
4	Lean angle sensor coupler	1	Disconnect.
5	Lean angle sensor	1	
6	Four-wheel-drive motor relay 1	1	
7	Four-wheel-drive motor relay 2	1	
8	Headlight relay	1	
9	EPS control unit coupler	5	Disconnect. For EPS models
10	EPS (electric power steering) control unit	1	For EPS models
11	ECU coupler	2	Disconnect.
12	ECU (engine control unit)	1	

GENERAL CHASSIS

Removing the electrical components tray 1/2

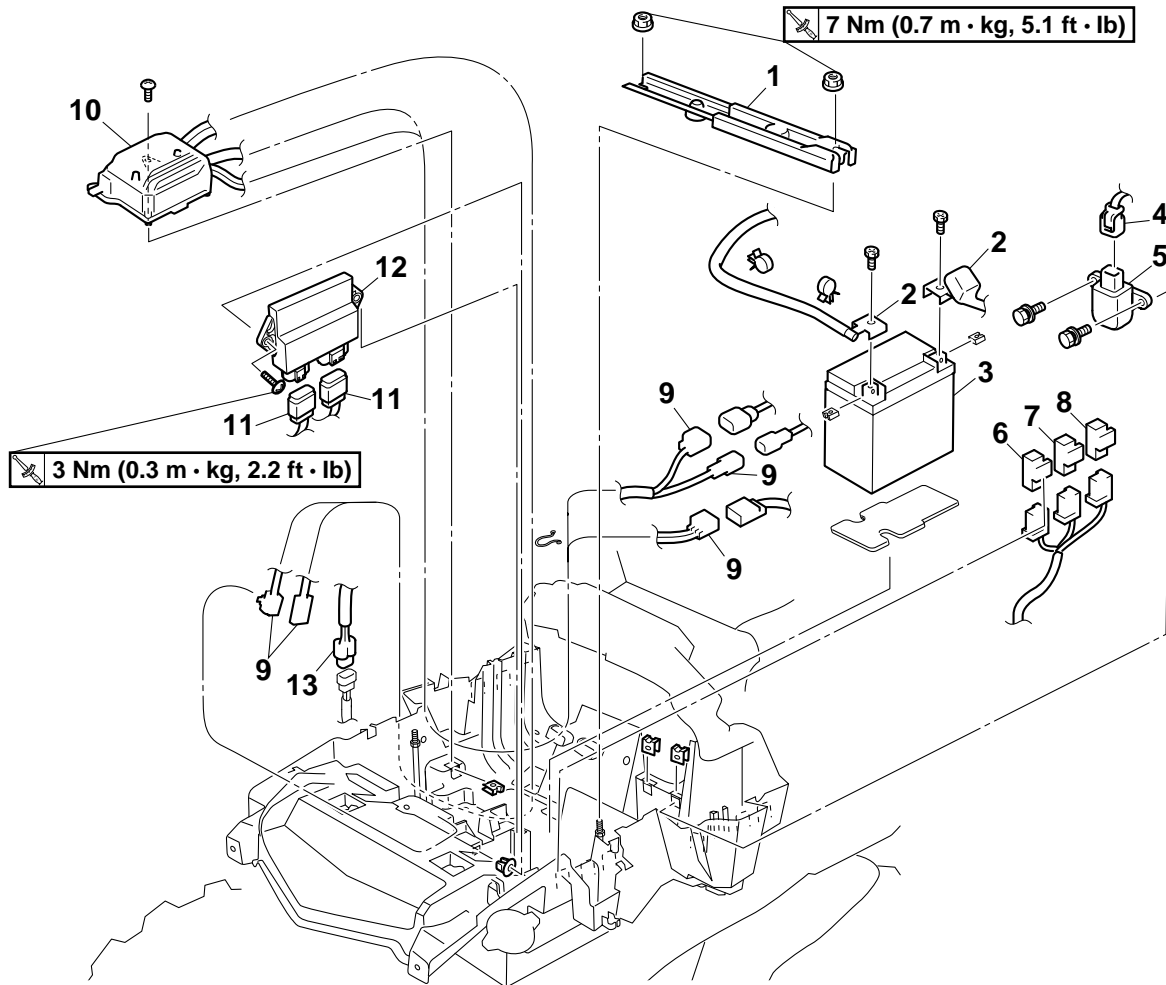

Order	Job/Parts to remove	Q'ty	Remarks
13	Radiator fan motor coupler	1	Disconnect.
			For installation, reverse the removal procedure.

GENERAL CHASSIS

Removing the electrical components tray 2/2

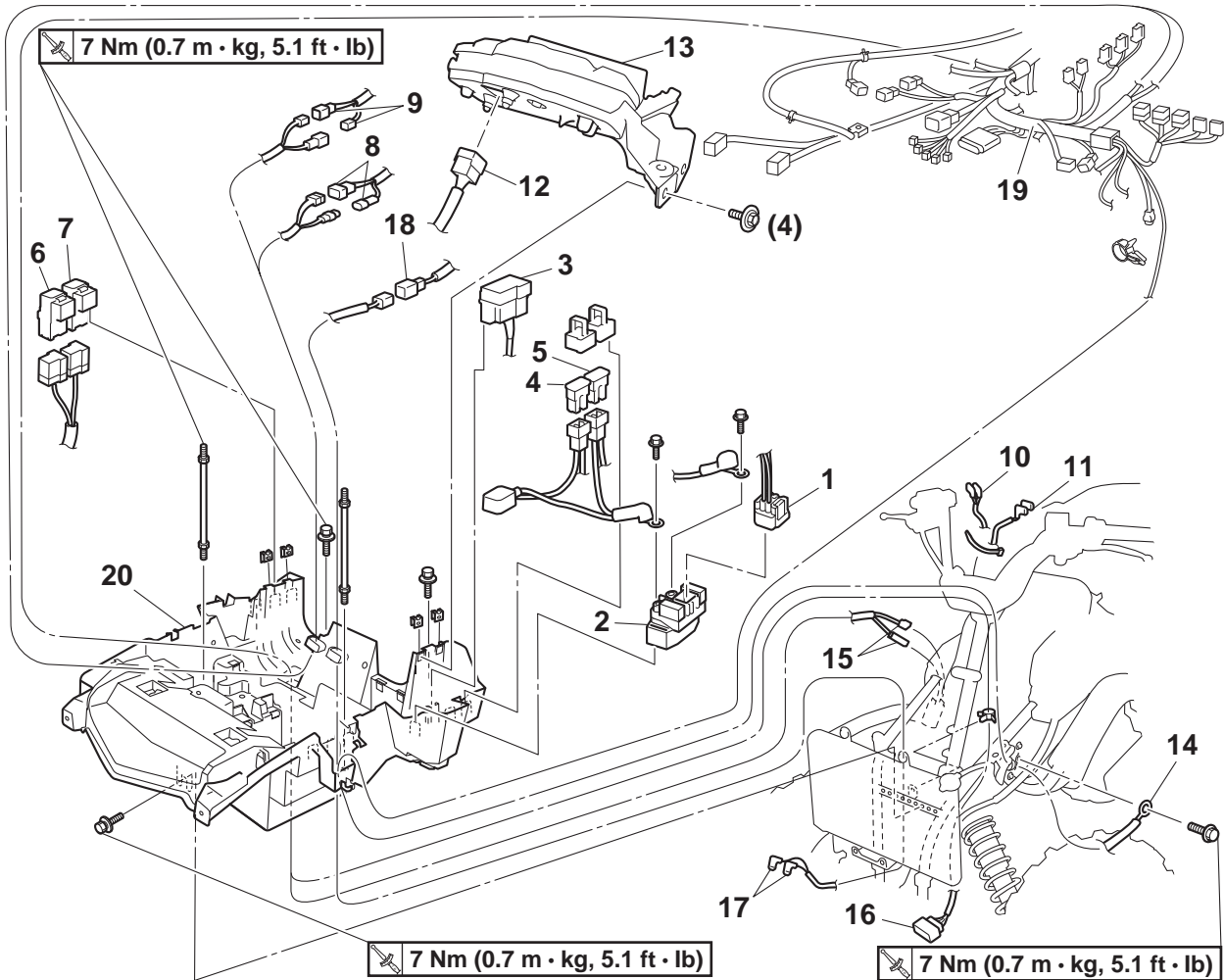

Order	Job/Parts to remove	Q'ty	Remarks
1	Starter relay coupler	1	Disconnect.
2	Starter relay	1	
3	Fuse box	1	
4	EPS fuse	1	For EPS models
5	Main fuse	1	
6	Radiator fan motor relay	1	
7	Fuel injection system relay	1	
8	Left handlebar switch coupler	2	Disconnect.
9	On-command four-wheel-drive motor switch and differential gear lock switch coupler	2	Disconnect.
10	Front brake light switch connector	2	Disconnect.
11	Rear brake light switch connector	2	Disconnect.
12	Meter assembly coupler	1	Disconnect.
13	Meter assembly	1	
14	Frame ground terminal	1	
15	Ignition coil connector	2	Disconnect.
16	Differential motor coupler	1	Disconnect.

GENERAL CHASSIS

Removing the electrical components tray 2/2

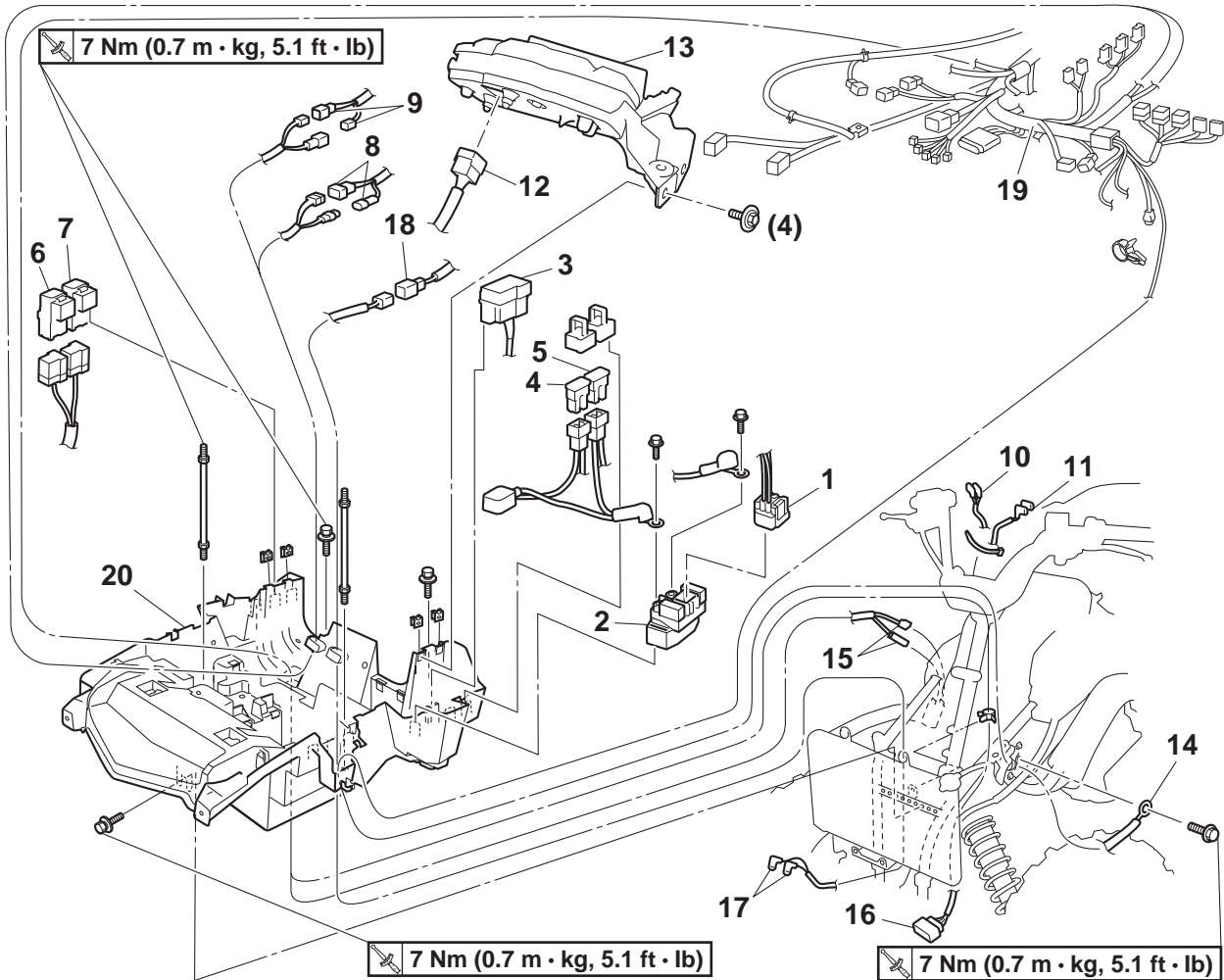

Order	Job/Parts to remove	Q'ty	Remarks
17	Horn connector	2	Disconnect. For Europe and Oceania.
18	Horn switch coupler	1	Disconnect. For Europe and Oceania.
19	Wire harness	1	
20	Electrical components tray	1	
			For installation, reverse the removal procedure.

GENERAL CHASSIS

Removing the footrest boards

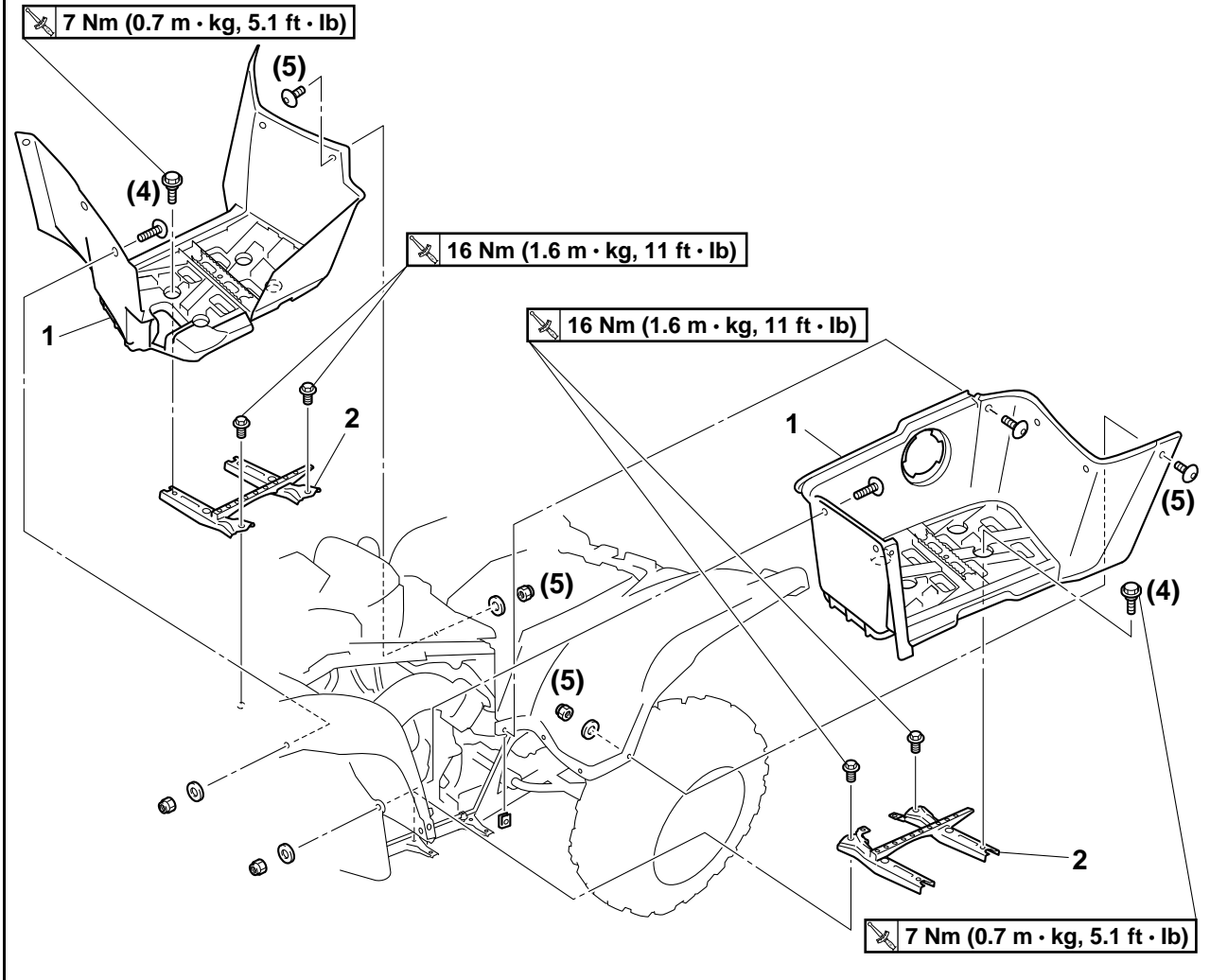

Order	Job/Parts to remove	Q'ty	Remarks
	Seat/Side panels		Refer to "Removing the seat and side panels".
1	Footrest board	2	
2	Footrest bracket	2	
			For installation, reverse the removal procedure.

EAS28P1003

INSTALLING THE FOOTREST BOARDS

The following procedure applies to both of the footrest boards.

1. Install:

- Footrest board



TIP

Tighten the footrest board bolts to the specified torque in the proper tightening sequence as shown.

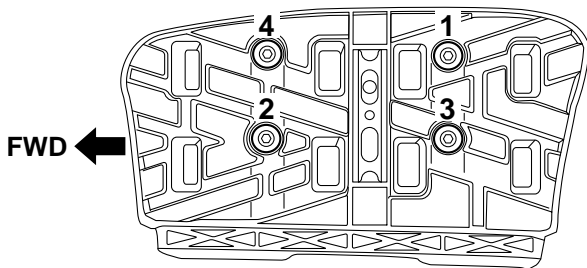

Removing the air filter case

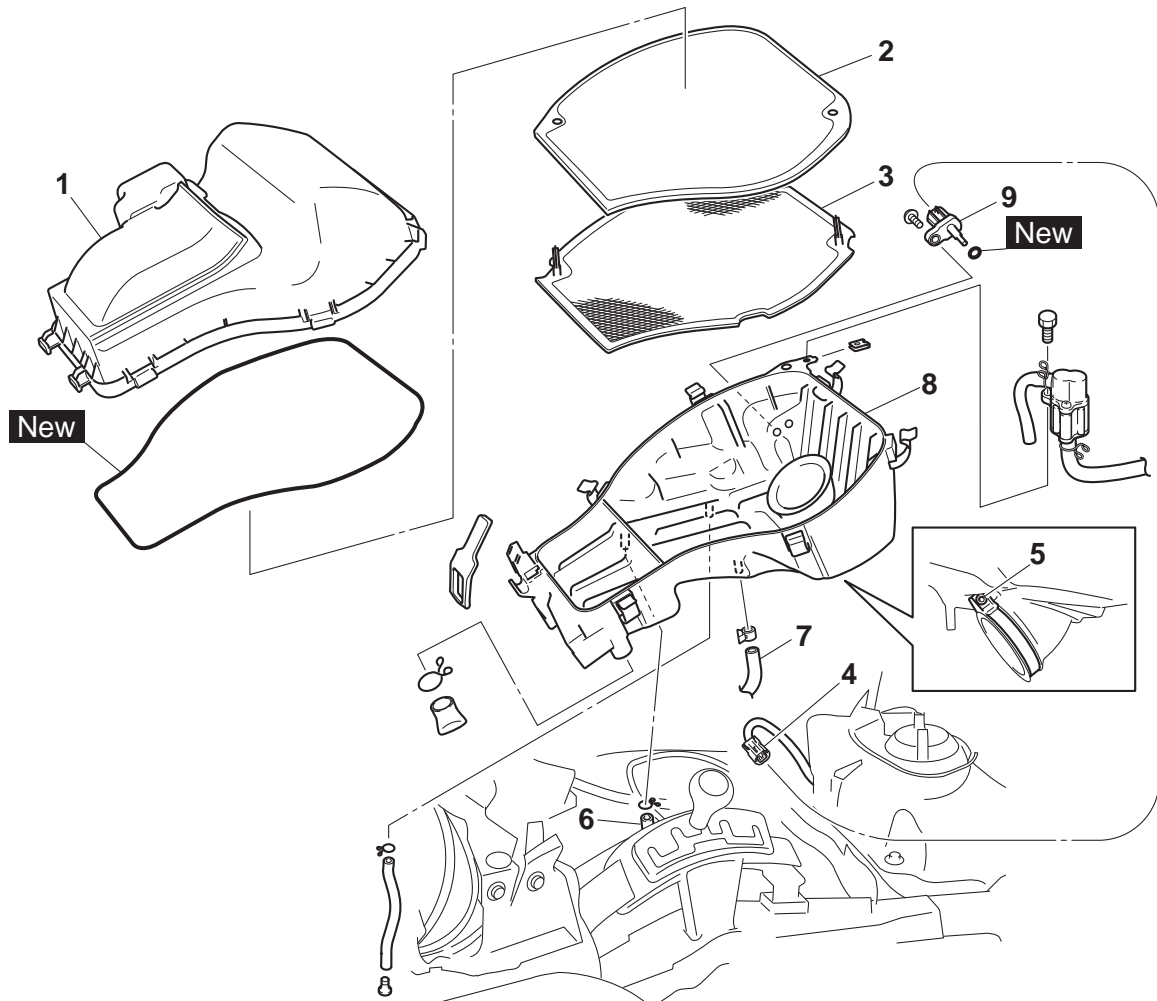

Order	Job/Parts to remove	Q'ty	Remarks
	Seat/Side panels		Refer to "Removing the seat and side panels".
1	Air filter case cover	1	
2	Air filter element	1	
3	Air filter element frame	1	
4	Intake air temperature sensor coupler	1	Disconnect.
5	Air filter case joint clamp screw	1	Loosen.
6	Cylinder head breather hose	1	Disconnect.
7	Air induction system hose (air cut-off valve assembly to air filter case)	1	Disconnect.
8	Air filter case	1	
9	Intake air temperature sensor	1	
			For installation, reverse the removal procedure.

EAS21870

FRONT WHEELS

Removing the front wheels and brake discs

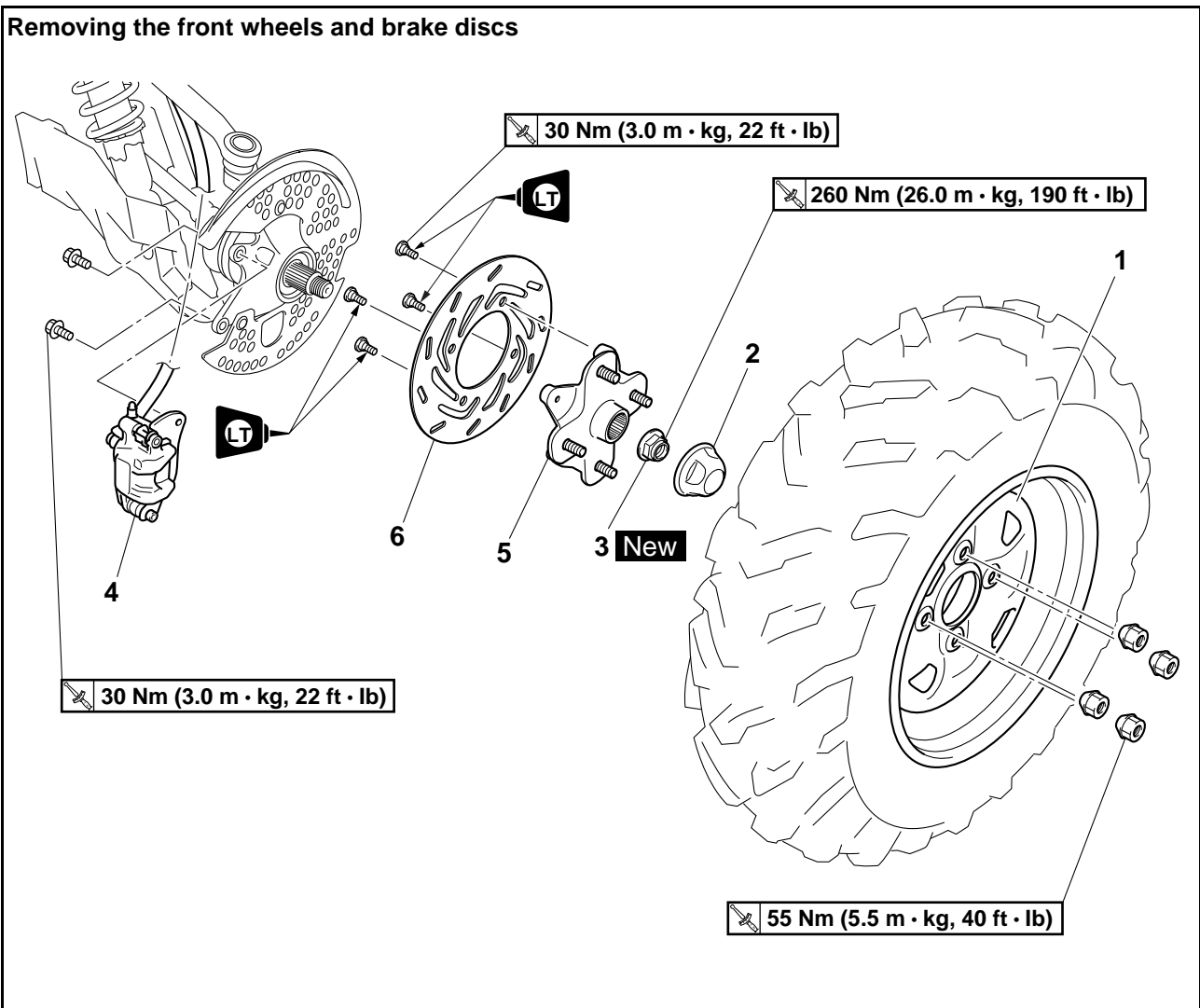

Order	Job/Parts to remove	Q'ty	Remarks
			The following procedure applies to both of the front wheels. Place the vehicle on a level surface.
1	Front wheel	1	
2	Wheel cap	1	
3	Front wheel axle nut	1	
4	Front brake caliper assembly	1	TIP _____ Do not squeeze the front brake lever when the brake caliper is off of the brake disc as the brake pads will be forced shut.
5	Front wheel hub	1	
6	Front brake disc	1	
			For installation, reverse the removal procedure.

EAS21890

REMOVING THE FRONT WHEELS

1. Place the vehicle on a level surface.
2. Elevate:
 - Front wheels

TIP

Place the vehicle on a suitable stand so that the front wheels are elevated.

3. Remove:

- Front brake calipers

TIP

Do not apply the brake lever when removing the brake calipers.

EAS1HPG004

REMOVING THE FRONT WHEEL HUBS

The following procedure applies to both of the front wheel hubs.

1. Straighten the wheel axle nut rib "a".

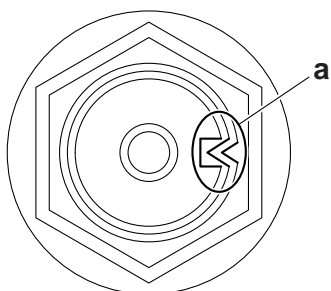

2. Remove:

- Wheel axle nut

3. Remove:

- Front brake caliper

TIP

Do not operate the brake lever when removing the brake caliper.

EAS29380

CHECKING THE FRONT WHEELS

The following procedure applies to both of the front wheels.

1. Check:

- Tire
- Wheel

Refer to "CHECKING THE TIRES" on page 3-31 and "CHECKING THE WHEELS" on page 3-32.

2. Measure:

- Radial wheel runout "1"
- Lateral wheel runout "2"

Over the specified limit → Replace the wheel or check the wheel bearing play.

Refer to "CHECKING THE STEERING KNUCKLES AND FRONT WHEEL BEARINGS" on page 4-57.



Radial wheel runout limit
2.0 mm (0.08 in)
Lateral wheel runout limit
2.0 mm (0.08 in)

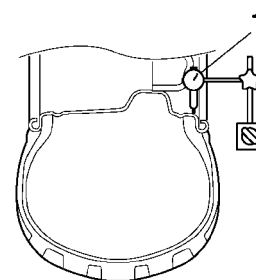
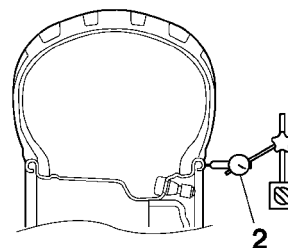

3. Check:

- Wheel balance
Out of balance → Adjust.

EWA15000



After replacing the tire, ride conservatively to allow the tire to be properly seated in the rim. Failure to do so may cause an accident resulting in vehicle damage and possible injury.

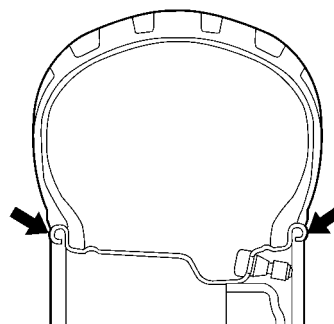

EAS28P1008

CHECKING THE FRONT WHEEL HUBS

The following procedure applies to both of the front wheel hubs.

FRONT WHEELS

1. Check:

- Wheel hub “1”
Cracks/damage → Replace.
- Splines (wheel hub) “2”
Wear/damage → Replace the wheel hub.

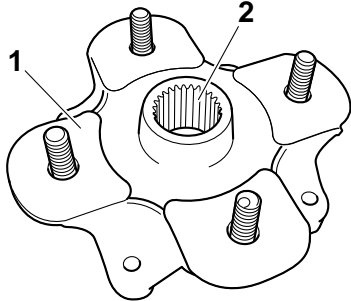

EAS28P1009

INSTALLING THE FRONT BRAKE DISCS

The following procedure applies to both of the front brake discs.

1. Install:

- Brake disc



Brake disc bolt
30 Nm (3.0 m·kg, 22 ft·lb)
LOCTITE®

TIP

Install the brake disc so that the recessed portion of the bolt hole faces away from the hub.

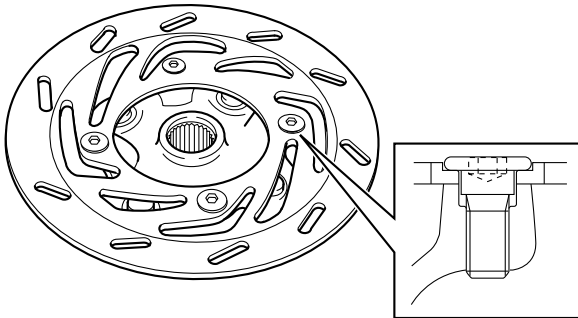

EAS28P1010

INSTALLING THE FRONT WHEEL HUBS

The following procedure applies to both of the front wheel hubs.

1. Install:

- Wheel axle nut **New**



Wheel axle nut
260 Nm (26.0 m·kg, 190 ft·lb)

TIP

- Do not apply oil to the threads of the nut.

- After tightening the nut, stake the collar of the nut into the notch of the shaft.

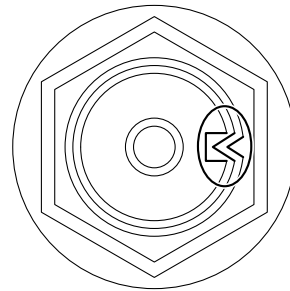

2. Check:

- Brake disc
Refer to “CHECKING THE FRONT BRAKE DISCS” on page 4-26.

EAS28P1011

INSTALLING THE FRONT WHEELS

The following procedure applies to both of the front wheels.

1. Install:

- Wheel

TIP

The arrow mark “1” on the tire must point in the direction of wheel rotation.

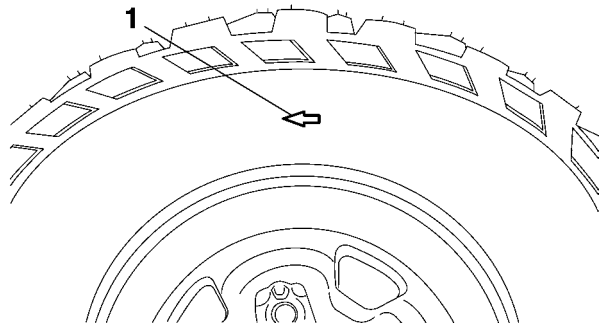

2. Tighten:

- Wheel nuts “1”



Wheel nut
55 Nm (5.5 m·kg, 40 ft·lb)

EWA28P1007

WARNING

Tapered wheel nuts “1” are used for both the front and rear wheels. Install each nut with its tapered side towards the wheel.

FRONT WHEELS

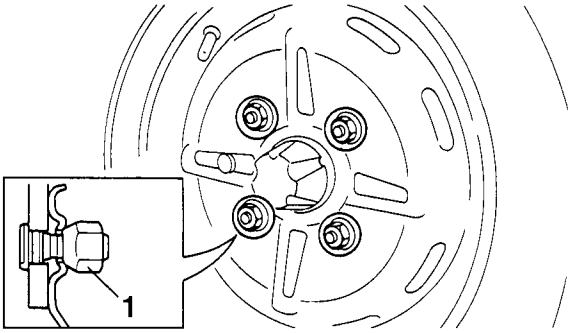

EAS22020

REAR WHEELS

Removing the rear wheels and brake discs

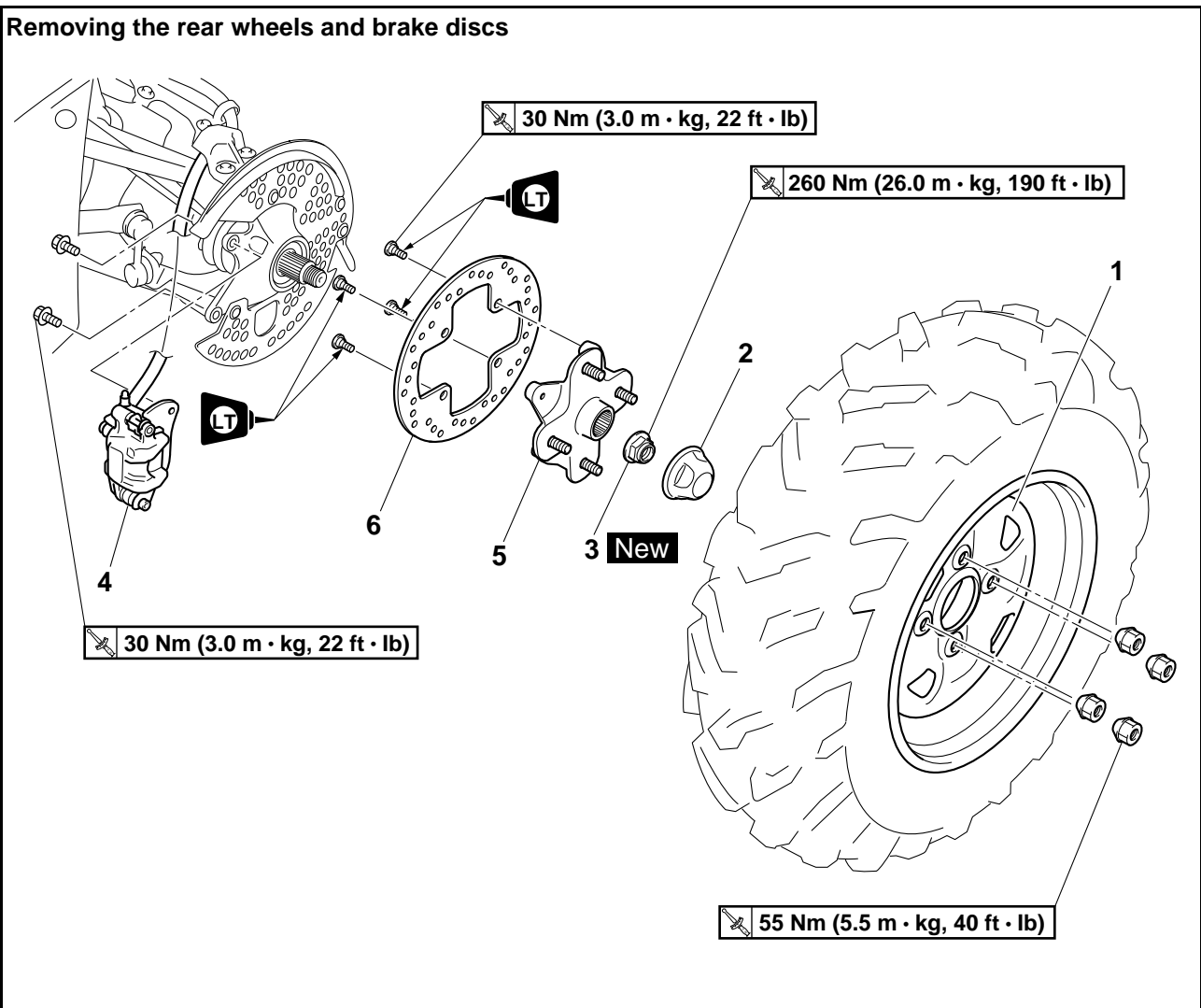

Order	Job/Parts to remove	Q'ty	Remarks
			The following procedure applies to both of the rear wheels. Place the vehicle on a level surface.
1	Rear wheel	1	
2	Wheel cap	1	
3	Rear wheel axle nut	1	
4	Rear brake caliper assembly	1	TIP _____ Do not squeeze the rear brake lever and brake pedal when the brake caliper is off of the brake disc as the brake pads will be forced shut. _____
5	Rear wheel hub	1	
6	Rear brake disc	1	
			For installation, reverse the removal procedure.

EAS22040

REMOVING THE REAR WHEELS

1. Place the vehicle on a level surface.
2. Elevate:
 - Rear wheels

TIP

Place the vehicle on a suitable stand so that the rear wheels are elevated.

3. Remove:

- Rear brake calipers

TIP

Do not apply the brake lever and depress the brake pedal when removing the brake calipers.

EAS1HPG005

REMOVING THE REAR WHEEL HUBS

The following procedure applies to both of the rear wheel hubs.

1. Remove:
 - Wheel axle nut

Refer to "REMOVING THE FRONT WHEEL HUBS" on page 4-15.
2. Remove:
 - Rear brake caliper

TIP

Do not operate the brake lever or brake pedal when removing the brake caliper.

EAS29430

CHECKING THE REAR WHEELS

The following procedure applies to both of the rear wheels.

1. Check:
 - Tire
 - Wheel

Refer to "CHECKING THE TIRES" on page 3-31 and "CHECKING THE WHEELS" on page 3-32.
2. Measure:
 - Radial wheel runout
 - Lateral wheel runout

Refer to "CHECKING THE FRONT WHEELS" on page 4-15.

Over the specified limit → Replace the wheel or check the wheel bearing play.

Refer to "CHECKING THE REAR KNUCKLES AND REAR WHEEL BEARINGS" on page 4-66.



Radial wheel runout limit
2.0 mm (0.08 in)
Lateral wheel runout limit
2.0 mm (0.08 in)

3. Check:

- Wheel balance

Refer to "CHECKING THE FRONT WHEELS" on page 4-15.

EAS29440

CHECKING THE REAR WHEEL HUBS

The following procedure applies to both of the rear wheel hubs.

1. Check:

- Wheel hub "1"

Cracks/damage → Replace.

- Splines (wheel hub) "2"

Wear/damage → Replace.

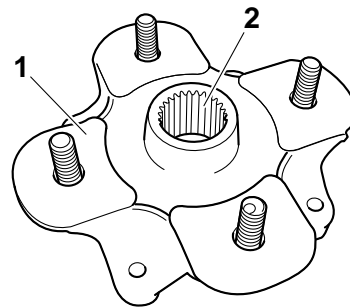

EAS28P1012

INSTALLING THE REAR BRAKE DISCS

The following procedure applies to both of the rear brake discs.

1. Install:

- Brake disc

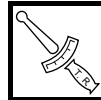

Brake disc bolt
30 Nm (3.0 m·kg, 22 ft·lb)
LOCTITE®

TIP

Install the brake disc so that the recessed portion of the bolt hole faces away from the hub.

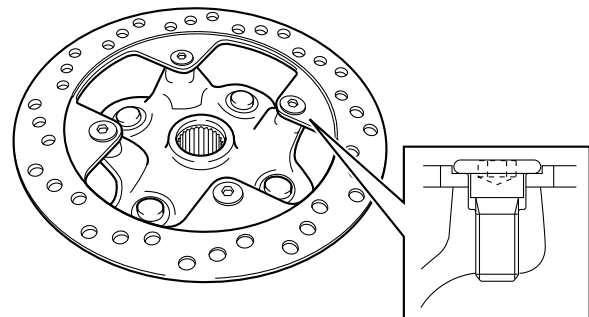

EAS28P1013

INSTALLING THE REAR WHEEL HUBS

The following procedure applies to both of the rear wheel hubs.

REAR WHEELS

1. Install:

- Wheel axle nut **New**



Wheel axle nut
260 Nm (26.0 m·kg, 190 ft·lb)

TIP

- Do not apply oil to the threads of the nut.
- After tightening the nut, stake the collar of the nut into the notch of the shaft.

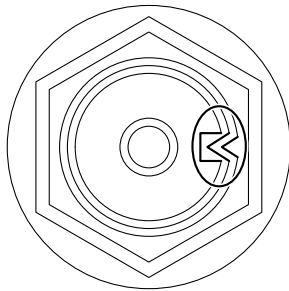

2. Check:

- Brake disc
Refer to "CHECKING THE REAR BRAKE DISCS" on page 4-38.

EAS28P1014

INSTALLING THE REAR WHEELS

The following procedure applies to both of the rear wheels.

1. Install:

- Wheel

TIP

The arrow mark "1" on the tire must point in the direction of wheel rotation.

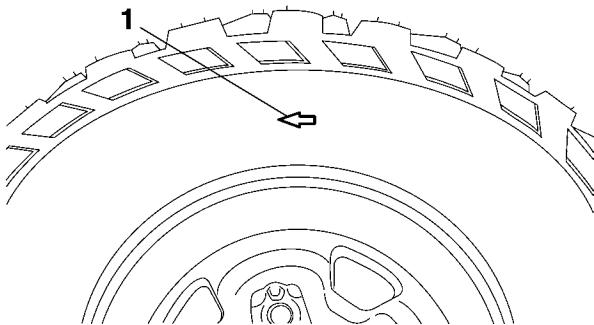

2. Tighten:

- Wheel nuts "1"



Wheel nut
55 Nm (5.5 m·kg, 40 ft·lb)

EWA28P1007

WARNING

Tapered wheel nuts "1" are used for both the front and rear wheels. Install each nut with its tapered side towards the wheel.

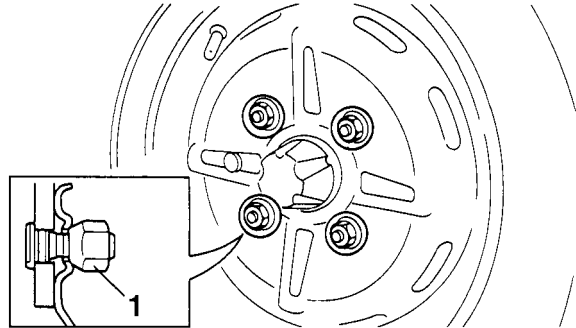

EAS22210

FRONT BRAKE

Removing the front brake pads

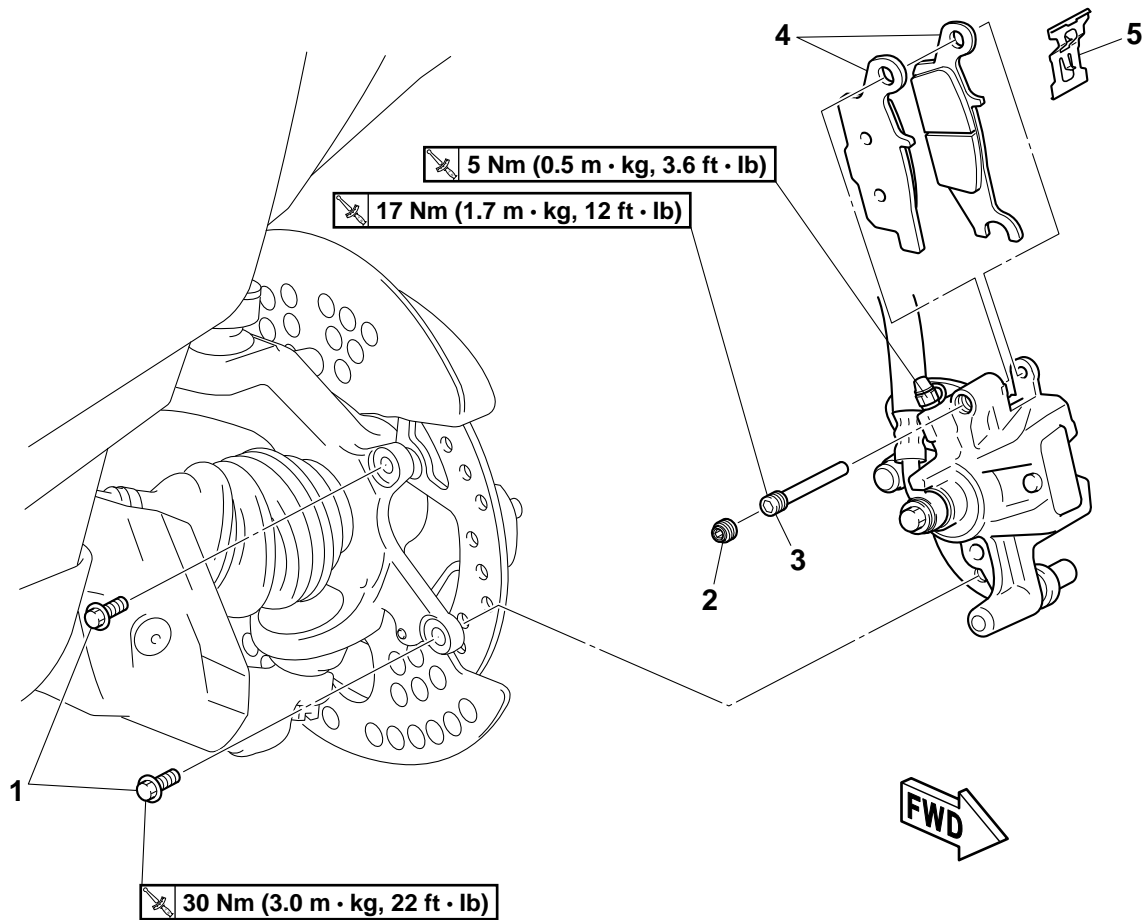

Order	Job/Parts to remove	Q'ty	Remarks
			The following procedure applies to both of the front brake calipers.
	Front wheel		Refer to "FRONT WHEELS" on page 4-14.
1	Front brake caliper bolt	2	
2	Brake pad holding bolt plug	1	
3	Brake pad holding bolt	1	
4	Front brake pad	2	
5	Brake pad spring	1	
			For installation, reverse the removal procedure.

FRONT BRAKE

Removing the front brake master cylinder

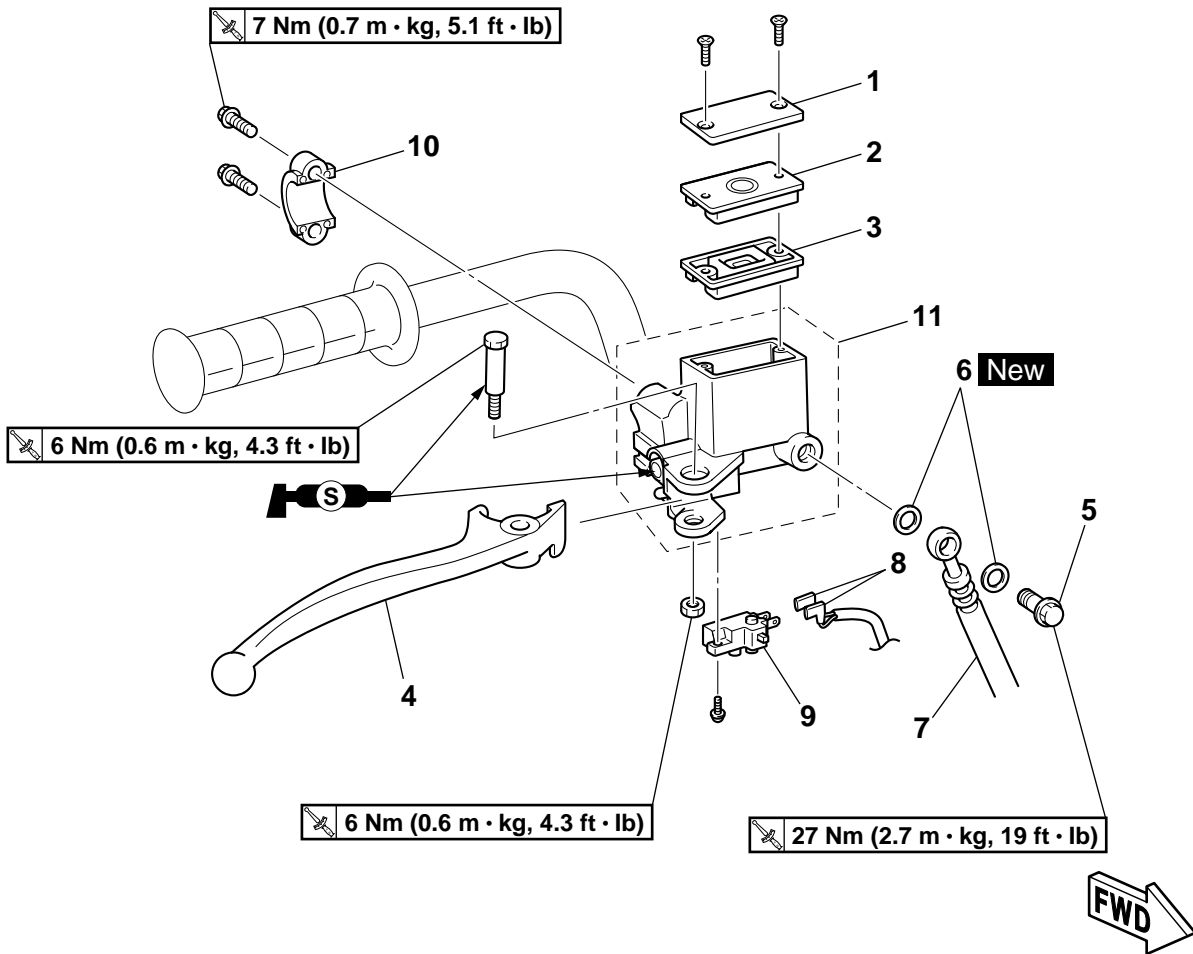

Order	Job/Parts to remove	Q'ty	Remarks
	Brake fluid		Drain. Refer to "BLEEDING THE HYDRAULIC BRAKE SYSTEM" on page 3-22.
	On-command four-wheel-drive motor switch and differential gear lock switch		Refer to "HANDLEBAR" on page 4-44.
1	Brake fluid reservoir cap	1	
2	Brake fluid reservoir diaphragm holder	1	
3	Brake fluid reservoir diaphragm	1	
4	Brake lever	1	
5	Union bolt	1	
6	Copper washer	2	
7	Front brake hose	1	Disconnect.
8	Front brake light switch connector	2	Disconnect.
9	Front brake light switch	1	
10	Front brake master cylinder holder	1	
11	Front brake master cylinder	1	
			For installation, reverse the removal procedure.

FRONT BRAKE

Disassembling the front brake master cylinder

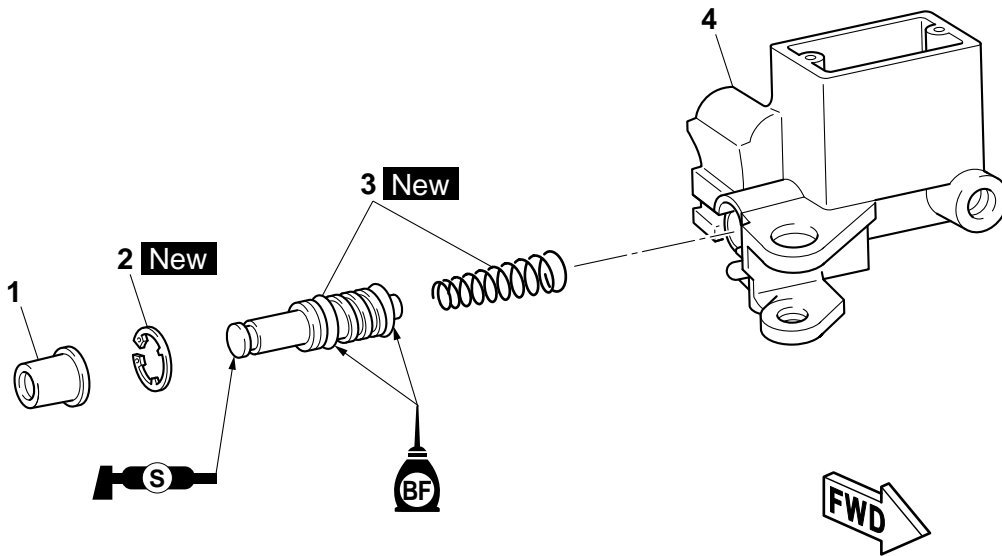

Order	Job/Parts to remove	Q'ty	Remarks
1	Dust boot	1	
2	Circlip	1	
3	Brake master cylinder kit	1	
4	Brake master cylinder body	1	
			For assembly, reverse the disassembly procedure.

FRONT BRAKE

Removing the front brake calipers

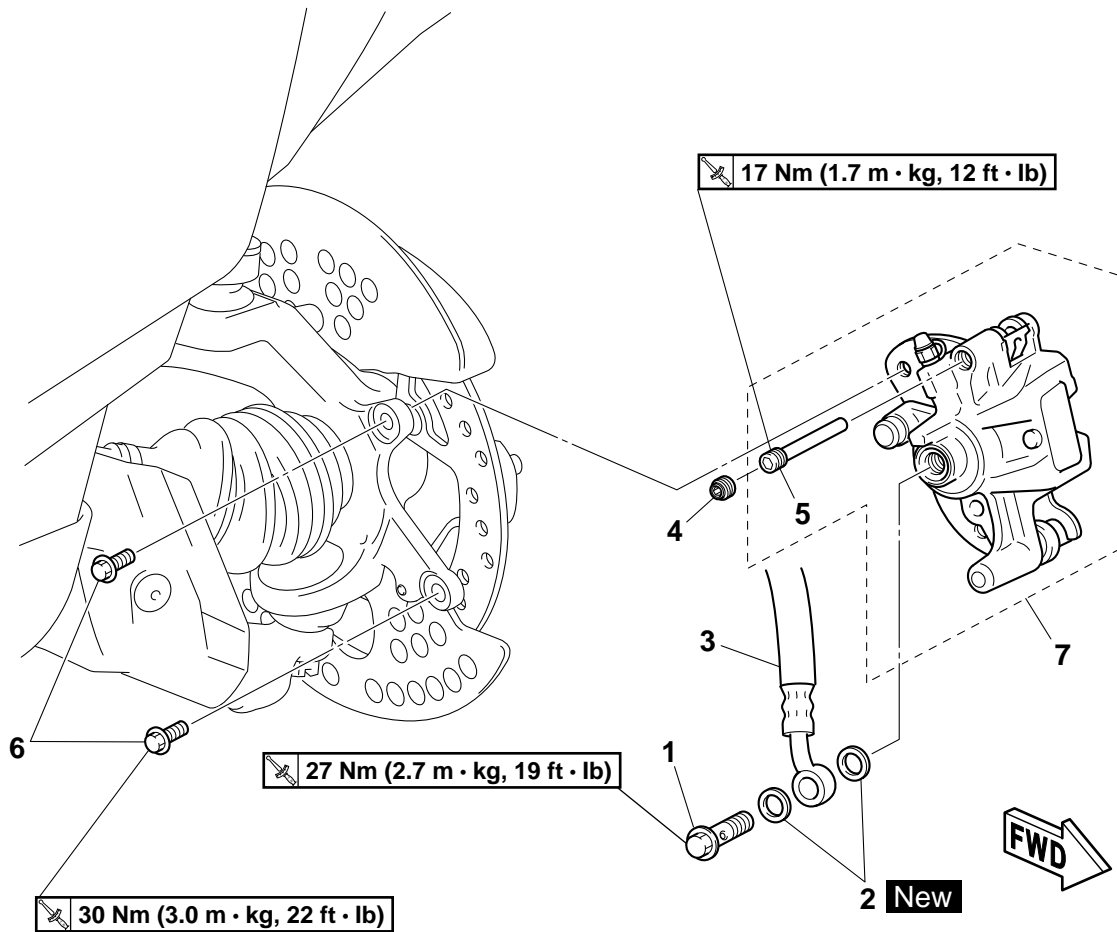

Order	Job/Parts to remove	Q'ty	Remarks
			The following procedure applies to both of the front brake calipers.
	Brake fluid		Drain. Refer to "BLEEDING THE HYDRAULIC BRAKE SYSTEM" on page 3-22.
	Front wheel		Refer to "FRONT WHEELS" on page 4-14.
1	Union bolt	1	
2	Copper washer	2	
3	Front brake hose	1	Disconnect.
4	Brake pad holding bolt plug	1	
5	Brake pad holding bolt	1	Loosen.
6	Front brake caliper bolt	2	
7	Front brake caliper assembly	1	
			For installation, reverse the removal procedure.

FRONT BRAKE

Disassembling the front brake calipers

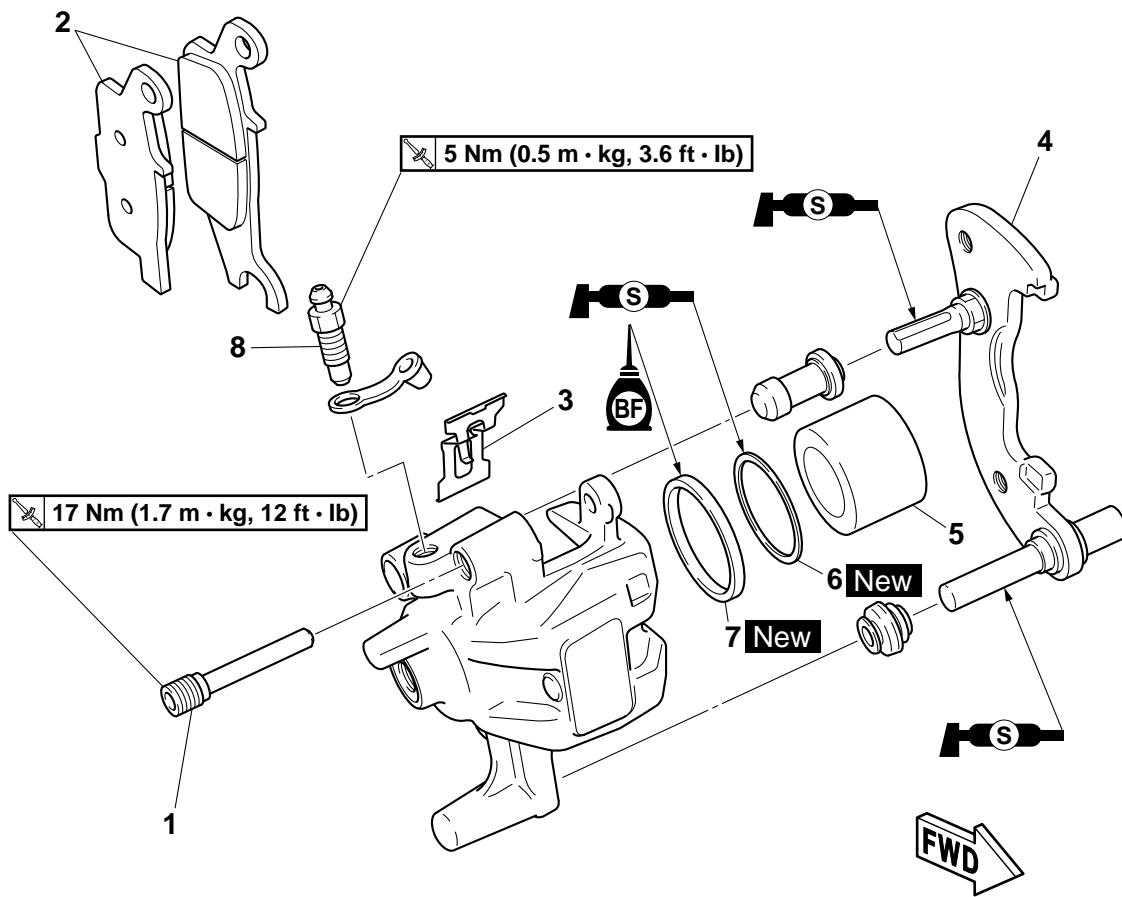

Order	Job/Parts to remove	Q'ty	Remarks
			The following procedure applies to both of the front brake calipers.
1	Brake pad holding bolt	1	
2	Brake pad	2	
3	Brake pad spring	1	
4	Brake caliper bracket	1	
5	Brake caliper piston	1	
6	Brake caliper dust seal	1	
7	Brake caliper piston seal	1	
8	Bleed screw	1	
			For assembly, reverse the disassembly procedure.

EAS22220

INTRODUCTION

EWA14100

WARNING

Disc brake components rarely require disassembly. Therefore, always follow these preventive measures:

- Never disassemble brake components unless absolutely necessary.
- If any connection on the hydraulic brake system is disconnected, the entire brake system must be disassembled, drained, cleaned, properly filled, and bled after reassembly.
- Never use solvents on internal brake components.
- Use only clean or new brake fluid for cleaning brake components.
- Brake fluid may damage painted surfaces and plastic parts. Therefore, always clean up any spilt brake fluid immediately.
- Avoid brake fluid coming into contact with the eyes as it can cause serious injury.
- **FIRST AID FOR BRAKE FLUID ENTERING THE EYES:**
- Flush with water for 15 minutes and get immediate medical attention.

EAS22240

CHECKING THE FRONT BRAKE DISCS

The following procedure applies to both brake discs.

1. Remove:
 - Front wheel
Refer to "FRONT WHEELS" on page 4-14.
2. Check:
 - Brake disc
Damage/galling → Replace.
3. Measure:
 - Brake disc deflection
Out of specification → Correct the brake disc deflection or replace the brake disc.



Brake disc deflection limit
0.1 mm (0.004 in)

- a. Hold the dial gauge at a right angle against the brake disc surface.
- b. Measure the deflection 3.0 mm (0.12 in) below the edge of the brake disc.

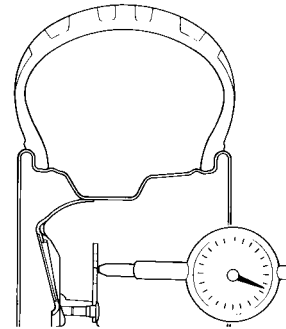

4. Measure:

- Brake disc thickness "a"
Measure the brake disc thickness at a few different locations.
Out of specification → Replace.



Brake disc thickness limit
3.0 mm (0.12 in)

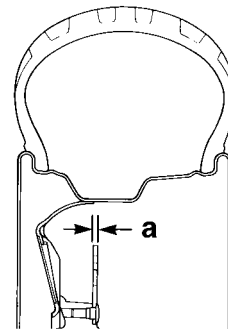

5. Adjust:

- Brake disc deflection

- a. Remove the brake disc.
- b. Rotate the brake disc by one bolt hole.
- c. Install the brake disc.



Front brake disc bolt
30 Nm (3.0 m·kg, 22 ft·lb)
LOCTITE®

TIP

Install the brake disc so that the recessed portion of the bolt hole faces away from the hub.

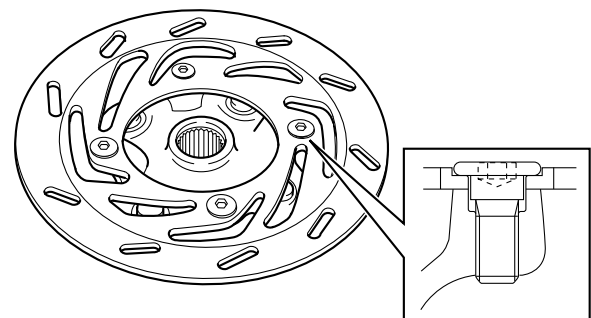

- d. Measure the brake disc deflection.
- e. If out of specification, repeat the adjustment steps until the brake disc deflection is within specification.
- f. If the brake disc deflection cannot be brought within specification, replace the brake disc.



6. Install:
- Front wheels
- Refer to "FRONT WHEELS" on page 4-14.

EAS22250

REPLACING THE FRONT BRAKE PADS

The following procedure applies to both brake calipers.

TIP

When replacing the brake pads, it is not necessary to disconnect the brake hose or disassemble the brake caliper.

- 1. Measure:
 - Brake pad wear limit "a"

Out of specification → Replace the brake pads and brake pad spring as a set.



Brake pad lining thickness (inner)	4.4 mm (0.17 in)
Limit	1.0 mm (0.04 in)
Brake pad lining thickness (outer)	4.4 mm (0.17 in)
Limit	1.0 mm (0.04 in)



- 2. Install:
 - Brake pad spring
 - Brake pads

TIP

Always install new brake pads and a new brake pad spring as a set.

- a. Connect a clear plastic hose "1" tightly to the bleed screw "2". Put the other end of the hose into an open container.

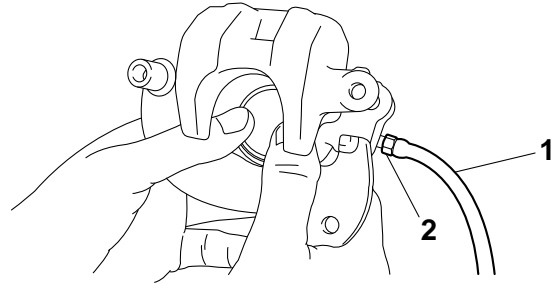

- b. Loosen the bleed screw and push the brake caliper piston into the brake caliper with your finger.
- c. Tighten the bleed screw.



Bleed screw
5 Nm (0.5 m·kg, 3.6 ft·lb)

- d. Install new brake pads and a new brake pad spring.



- 3. Install:
 - Brake pad holding bolt
 - Brake pad holding bolt plug
 - Brake caliper



Brake pad holding bolt
17 Nm (1.7 m·kg, 12 ft·lb)
Brake caliper bolt
30 Nm (3.0 m·kg, 22 ft·lb)

- 4. Check:
 - Brake fluid level

Below the minimum level mark → Add the specified brake fluid to the proper level. Refer to "CHECKING THE BRAKE FLUID LEVEL" on page 3-20.
- 5. Check:
 - Brake lever operation

Soft or spongy feeling → Bleed the brake system. Refer to "BLEEDING THE HYDRAULIC BRAKE SYSTEM" on page 3-22.

EAS22310

DISASSEMBLING THE FRONT BRAKE CALIPERS

The following procedure applies to both of the brake calipers.

TIP

Before disassembling the brake caliper, drain the brake fluid from the entire brake system.

1. Remove:

- Brake caliper piston “1”
- Brake caliper dust seal “2”
- Brake caliper piston seal “3”

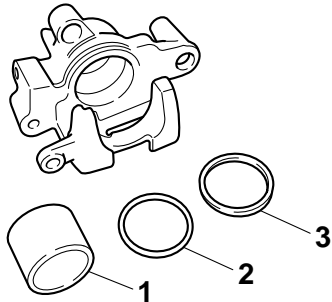

- a. Blow compressed air into the brake hose joint opening “a” to force out the piston from the brake caliper.

EWA13550

⚠ WARNING

- Cover the brake caliper piston with a rag. Be careful not to get injured when the piston is expelled from the brake caliper.
- Never try to pry out the brake caliper piston.

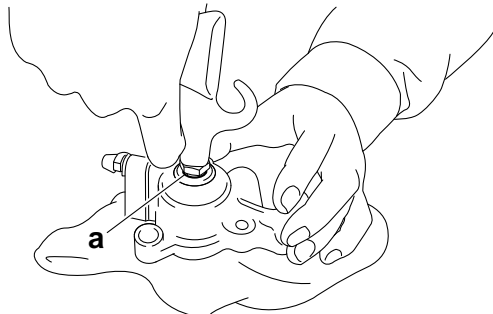

- b. Remove the brake caliper dust seal and brake caliper piston seal.



EAS22390

CHECKING THE FRONT BRAKE CALIPERS

The following procedure applies to both of the brake calipers.

Brake pads	If necessary
Piston seals, dust seals	Every two years
Brake hoses	Every four years
Brake fluid	Every two years and whenever the brake is disassembled

1. Check:

- Brake caliper piston “1”
Rust/scratches/wear → Replace the brake caliper piston.
- Brake caliper cylinder “2”
Scratches/wear → Replace the brake caliper assembly.
- Brake caliper body “3”
Cracks/damage → Replace the brake caliper assembly.
- Brake fluid delivery passages (brake caliper body)
Obstruction → Blow out with compressed air.

EWA28P1002

⚠ WARNING

Whenever a brake caliper is disassembled, replace the brake caliper piston seals and dust seals.

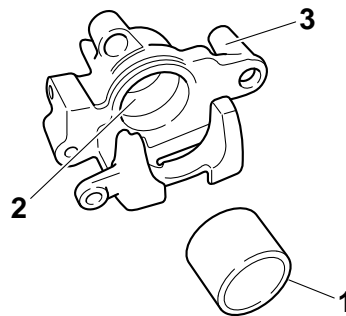

EAS22410

ASSEMBLING THE FRONT BRAKE CALIPERS

The following procedure applies to both of the brake calipers.

EWA28P1003

⚠ WARNING

- Before installation, all internal brake components should be cleaned and lubricated with clean or new brake fluid.
- Never use solvents on internal brake components as they will cause the piston seals to swell and distort.

- Whenever a brake caliper is disassembled, replace the brake caliper piston seal and dust seal.



**Specified brake fluid
DOT 4**

EAS22440

INSTALLING THE FRONT BRAKE CALIPERS

The following procedure applies to both of the brake calipers.

1. Install:
 - Brake caliper assembly
 - Brake caliper bolts "1"
 - Brake hose "2"
 - Copper washers "3" **New**
 - Brake hose union bolt "4"



**Brake caliper bolt
30 Nm (3.0 m·kg, 22 ft·lb)
Brake hose union bolt
27 Nm (2.7 m·kg, 19 ft·lb)**

EWA13530



WARNING

Proper brake hose routing is essential to insure safe vehicle operation. Refer to "CABLE ROUTING" on page 2-31.

ECA28P1014



NOTICE

When installing the brake hose onto the brake caliper, make sure the brake pipe touches the projection "a" on the brake caliper.

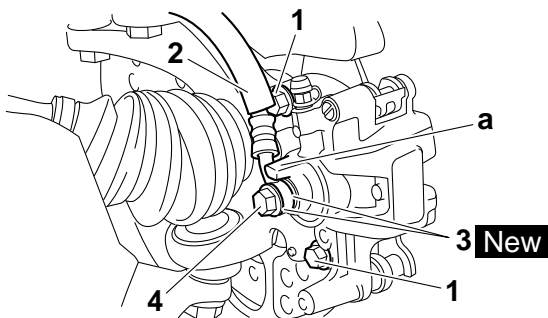

2. Fill:
 - Brake master cylinder reservoir (with the specified amount of the specified brake fluid)



**Specified brake fluid
DOT 4**

EWA13090



WARNING

- Use only the designated brake fluid. Other brake fluids may cause the rubber seals to deteriorate, causing leakage and poor brake performance.
- Refill with the same type of brake fluid that is already in the system. Mixing brake fluids may result in a harmful chemical reaction, leading to poor brake performance.
- When refilling, be careful that water does not enter the brake fluid reservoir. Water will significantly lower the boiling point of the brake fluid and could cause vapor lock.

ECA13540



NOTICE

Brake fluid may damage painted surfaces and plastic parts. Therefore, always clean up any spilt brake fluid immediately.

3. Bleed:
 - Brake system
Refer to "BLEEDING THE HYDRAULIC BRAKE SYSTEM" on page 3-22.
4. Check:
 - Brake fluid level
Below the minimum level mark → Add the specified brake fluid to the proper level.
Refer to "CHECKING THE BRAKE FLUID LEVEL" on page 3-20.
5. Check:
 - Brake lever operation
Soft or spongy feeling → Bleed the brake system.
Refer to "BLEEDING THE HYDRAULIC BRAKE SYSTEM" on page 3-22.

EAS22500

CHECKING THE FRONT BRAKE MASTER CYLINDER

1. Check:
 - Brake master cylinder
Damage/scratches/wear → Replace.
 - Brake fluid delivery passages (brake master cylinder body)
Obstruction → Blow out with compressed air.
2. Check:
 - Brake master cylinder kit
Damage/scratches/wear → Replace.
3. Check:
 - Brake master cylinder reservoir
Cracks/damage → Replace.
 - Brake master cylinder reservoir diaphragm
Cracks/damage → Replace.

4. Check:

- Brake hoses
Cracks/damage/wear → Replace.

EAS22520

ASSEMBLING THE FRONT BRAKE MASTER CYLINDER

EWA28P1008

WARNING

- Before installation, all internal brake components should be cleaned and lubricated with clean or new brake fluid.
- Never use solvents on internal brake components.
- Whenever a master cylinder is disassembled, replace the brake master cylinder kit.



**Specified brake fluid
DOT 4**

EAS22530

INSTALLING THE FRONT BRAKE MASTER CYLINDER

1. Install:

- Brake master cylinder "1"
- Brake master cylinder holder "2"



**Brake master cylinder holder bolt
7 Nm (0.7 m·kg, 5.1 ft·lb)**

TIP

- Align the end of the brake master cylinder holder with the punch mark "a" on the handlebar.
- Install the brake master cylinder holder with the "UP" mark "b" facing up.
- Install the brake master cylinder holder so that the gaps between the brake master cylinder and the brake master cylinder holder are equal.

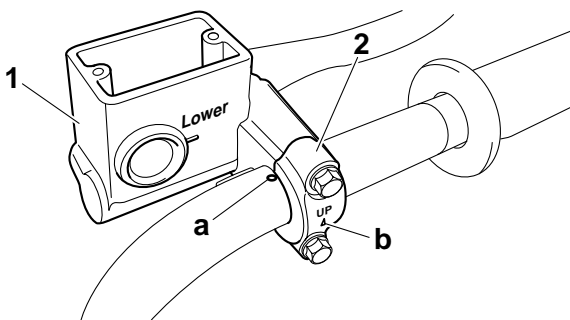

2. Install:

- Brake hose
- Copper washers **New**
- Brake hose union bolt



**Brake hose union bolt
27 Nm (2.7 m·kg, 19 ft·lb)**

EWA13530

WARNING

Proper brake hose routing is essential to insure safe vehicle operation. Refer to "CABLE ROUTING" on page 2-31.

TIP

- While holding the brake hose, tighten the union bolt as shown.
- Turn the handlebar to the left and right to make sure the brake hose does not touch other parts (e.g., wire harness, cables, leads). Correct if necessary.

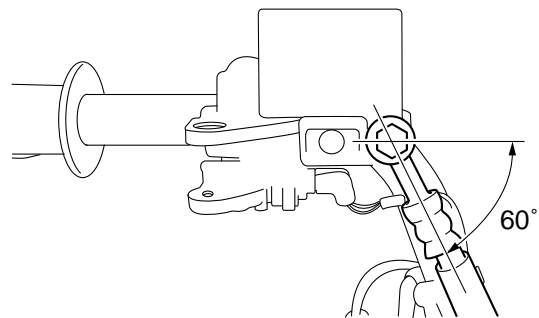

3. Fill:

- Brake master cylinder reservoir
(with the specified amount of the specified brake fluid)



**Specified brake fluid
DOT 4**

EWA13540

WARNING

- Use only the designated brake fluid. Other brake fluids may cause the rubber seals to deteriorate, causing leakage and poor brake performance.
- Refill with the same type of brake fluid that is already in the system. Mixing brake fluids may result in a harmful chemical reaction, leading to poor brake performance.
- When refilling, be careful that water does not enter the brake master cylinder reservoir. Water will significantly lower the boiling point of the brake fluid and could cause vapor lock.

ECA13540

NOTICE

Brake fluid may damage painted surfaces and plastic parts. Therefore, always clean up any spilt brake fluid immediately.

4. Bleed:

- Brake system
Refer to "BLEEDING THE HYDRAULIC BRAKE SYSTEM" on page 3-22.

5. Check:

- Brake fluid level
Below the minimum level mark → Add the specified brake fluid to the proper level.
Refer to "CHECKING THE BRAKE FLUID LEVEL" on page 3-20.

6. Check:

- Brake lever operation
Soft or spongy feeling → Bleed the brake system.
Refer to "BLEEDING THE HYDRAULIC BRAKE SYSTEM" on page 3-22.

EAS22550

REAR BRAKE

Removing the rear brake pads

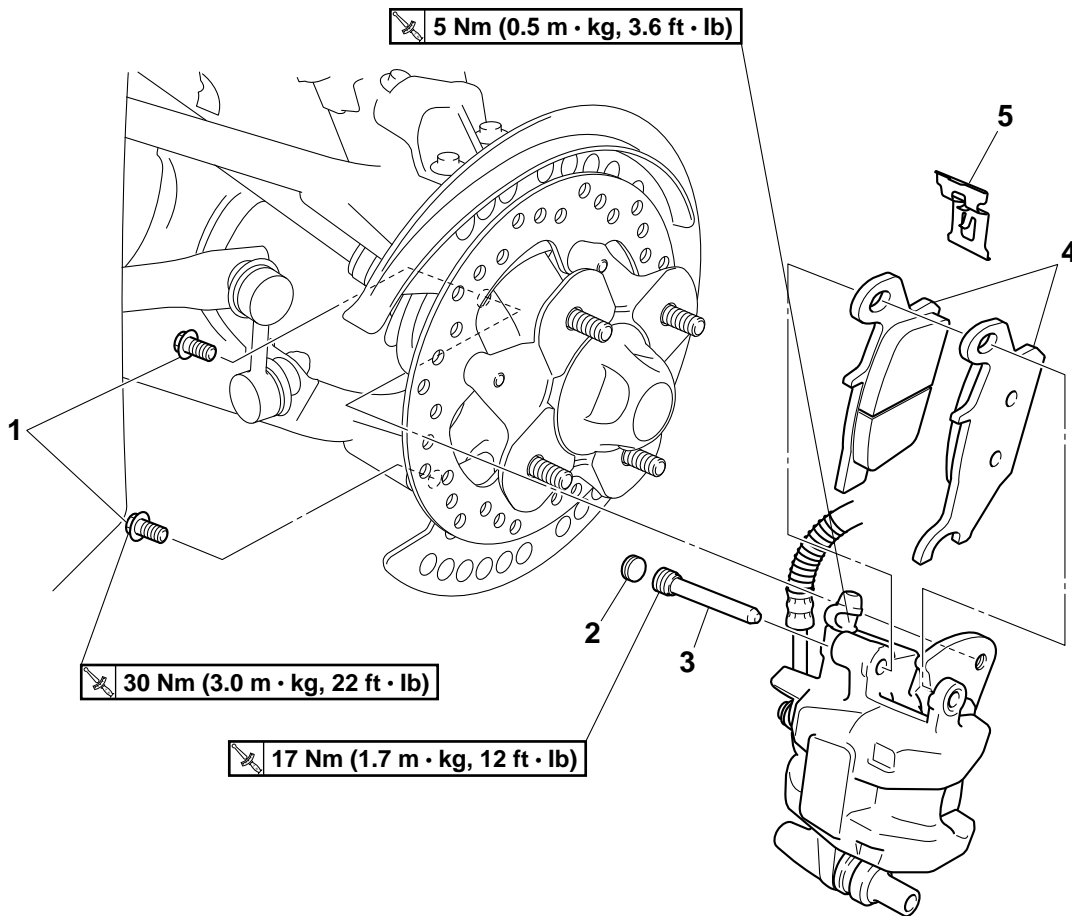

Order	Job/Parts to remove	Q'ty	Remarks
			The following procedure applies to both of the rear brake calipers.
	Rear wheel		Refer to "REAR WHEELS" on page 4-18.
1	Rear brake caliper bolt	2	
2	Brake pad holding bolt plug	1	
3	Brake pad holding bolt	1	
4	Rear brake pad	2	
5	Brake pad spring	1	
			For installation, reverse the removal procedure.

REAR BRAKE

Removing the rear brake master cylinder

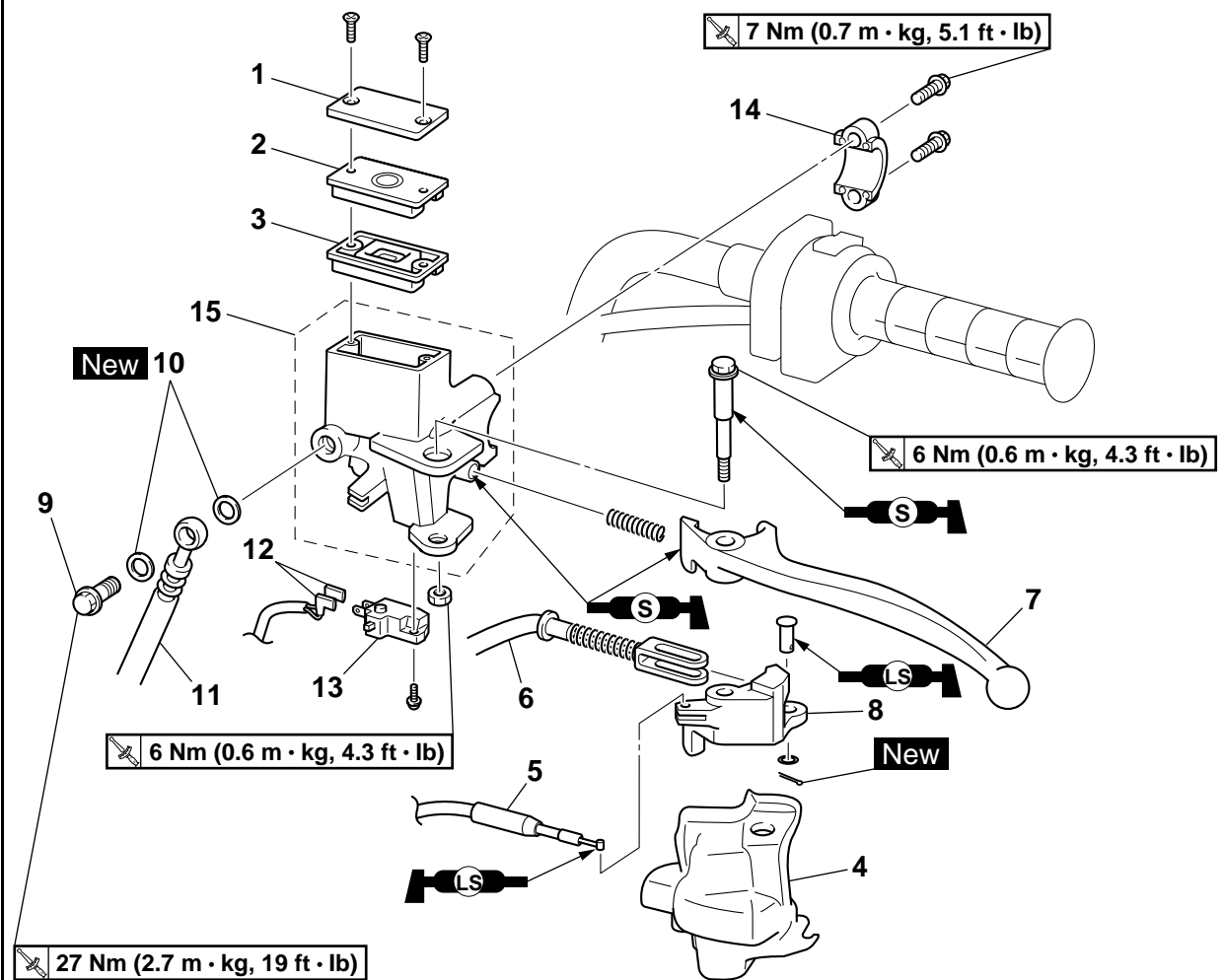

Order	Job/Parts to remove	Q'ty	Remarks
	Brake fluid		Drain. Refer to "BLEEDING THE HYDRAULIC BRAKE SYSTEM" on page 3-22.
1	Brake fluid reservoir cap	1	
2	Brake fluid reservoir diaphragm holder	1	
3	Brake fluid reservoir diaphragm	1	
4	Rear brake lever cover	1	
5	Shift control cable	1	Disconnect.
6	Rear brake cable	1	Disconnect.
7	Brake lever	1	
8	Brake lever bracket	1	
9	Union bolt	1	
10	Copper washer	2	
11	Rear brake hose	1	Disconnect.
12	Rear brake light switch connector	2	Disconnect.
13	Rear brake light switch	1	
14	Rear brake master cylinder holder	1	

REAR BRAKE

Removing the rear brake master cylinder

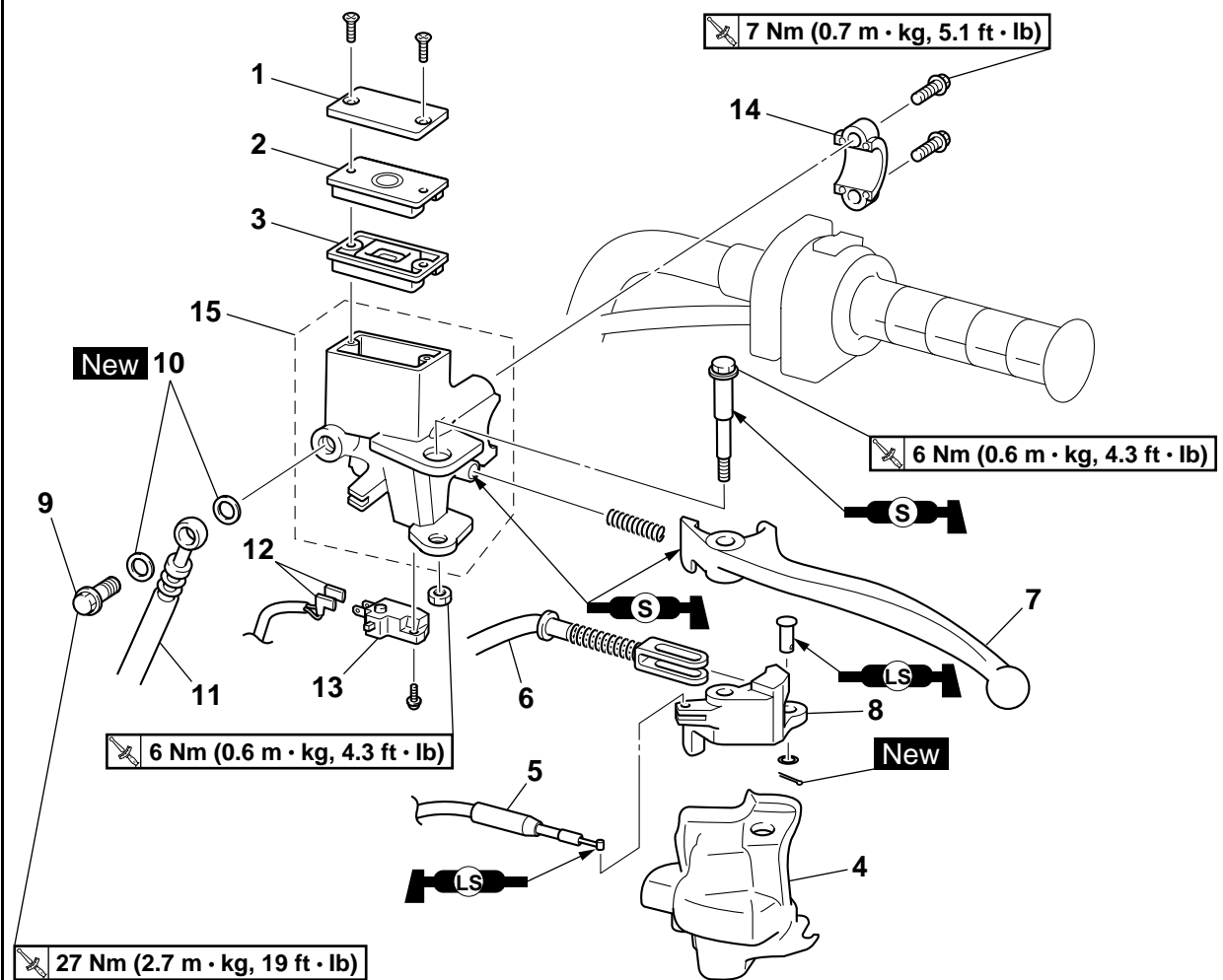

Order	Job/Parts to remove	Q'ty	Remarks
15	Rear brake master cylinder	1	
			For installation, reverse the removal procedure.

REAR BRAKE

Disassembling the rear brake master cylinder

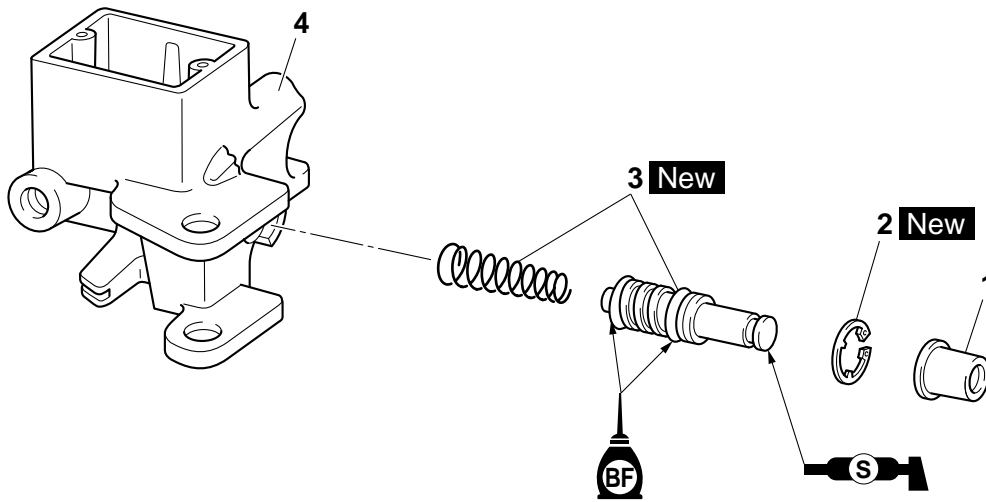

Order	Job/Parts to remove	Q'ty	Remarks
1	Dust boot	1	
2	Circlip	1	
3	Brake master cylinder kit	1	
4	Brake master cylinder body	1	
			For assembly, reverse the disassembly procedure.

REAR BRAKE

Removing the rear brake calipers

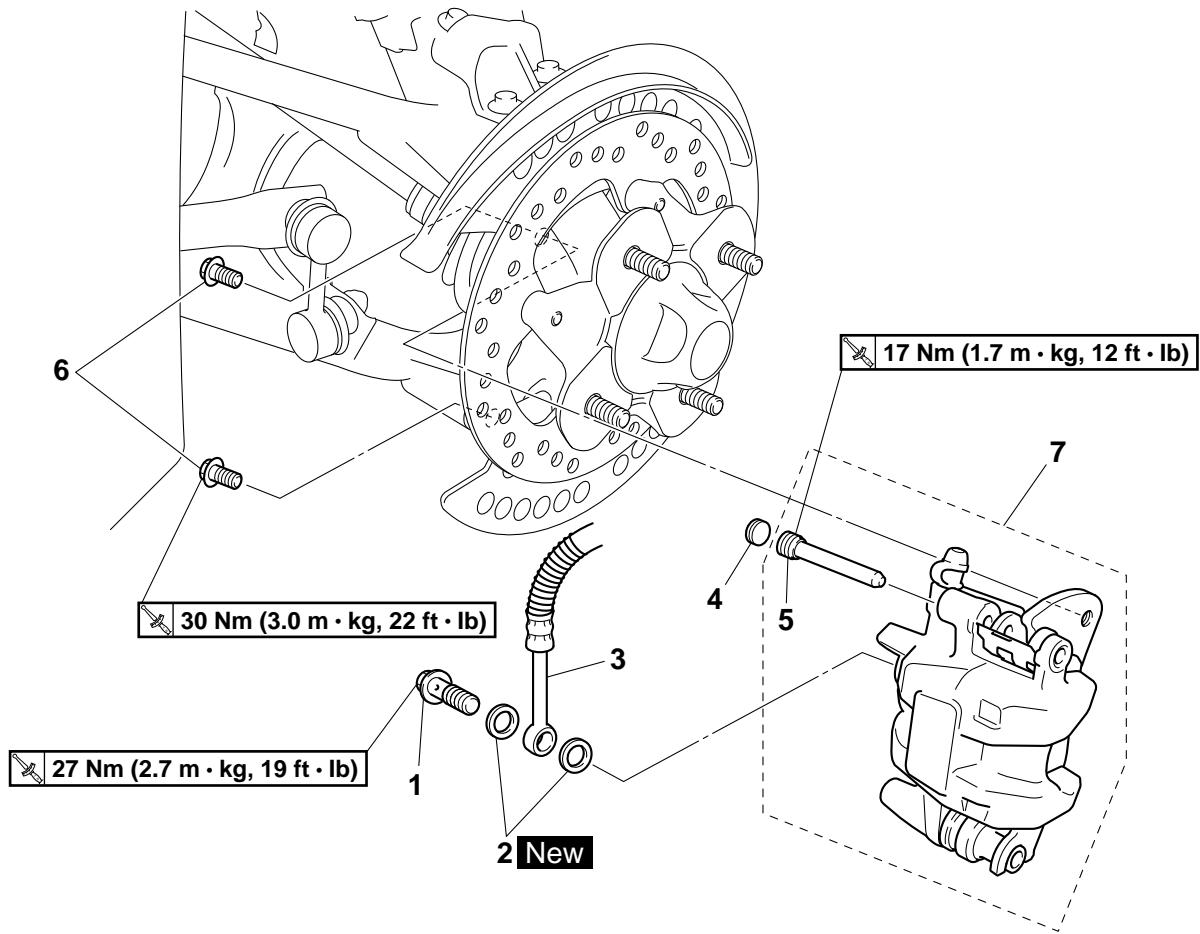

Order	Job/Parts to remove	Q'ty	Remarks
			The following procedure applies to both of the rear brake calipers.
	Brake fluid		Drain. Refer to "BLEEDING THE HYDRAULIC BRAKE SYSTEM" on page 3-22.
	Rear wheel		Refer to "REAR WHEELS" on page 4-18.
1	Union bolt	1	
2	Copper washer	2	
3	Rear brake hose	1	Disconnect.
4	Brake pad holding bolt plug	1	
5	Brake pad holding bolt	1	Loosen.
6	Rear brake caliper bolt	2	
7	Rear brake caliper assembly	1	
			For installation, reverse the removal procedure.

REAR BRAKE

Disassembling the rear brake calipers

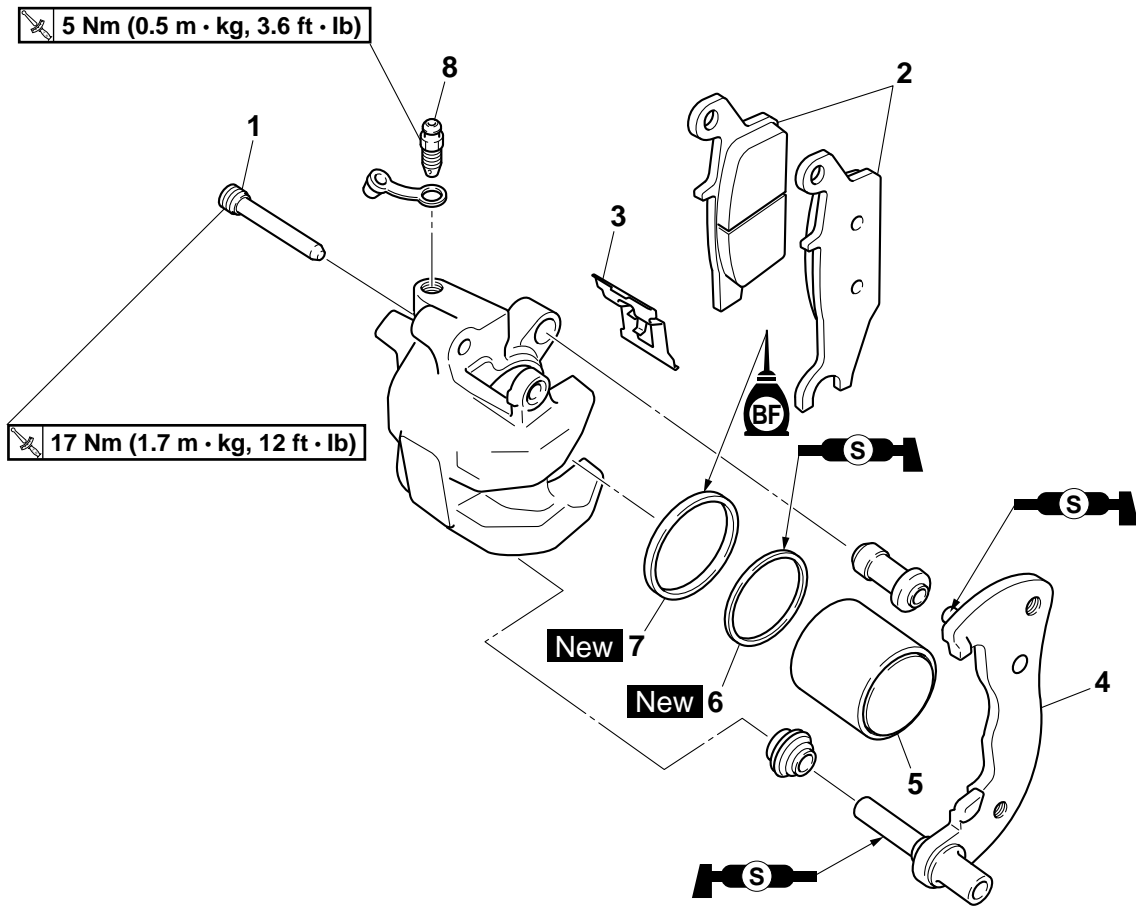

Order	Job/Parts to remove	Q'ty	Remarks
			The following procedure applies to both of the rear brake calipers.
1	Brake pad holding bolt	1	
2	Brake pad	2	
3	Brake pad spring	1	
4	Brake caliper bracket	1	
5	Brake caliper piston	1	
6	Brake caliper dust seal	1	
7	Brake caliper piston seal	1	
8	Bleed screw	1	
			For assembly, reverse the disassembly procedure.

EAS22560

INTRODUCTION

EWA14100

WARNING

Disc brake components rarely require disassembly. Therefore, always follow these preventive measures:

- Never disassemble brake components unless absolutely necessary.
- If any connection on the hydraulic brake system is disconnected, the entire brake system must be disassembled, drained, cleaned, properly filled, and bled after reassembly.
- Never use solvents on internal brake components.
- Use only clean or new brake fluid for cleaning brake components.
- Brake fluid may damage painted surfaces and plastic parts. Therefore, always clean up any spilt brake fluid immediately.
- Avoid brake fluid coming into contact with the eyes as it can cause serious injury.
- **FIRST AID FOR BRAKE FLUID ENTERING THE EYES:**
- Flush with water for 15 minutes and get immediate medical attention.

EAS22570

CHECKING THE REAR BRAKE DISCS

The following procedure applies to both brake discs.

1. Remove:
 - Rear wheel
Refer to "REAR WHEELS" on page 4-18.
2. Check:
 - Brake disc
Damage/galling → Replace.
3. Measure:
 - Brake disc deflection
Out of specification → Correct the brake disc deflection or replace the brake disc.
Refer to "CHECKING THE FRONT BRAKE DISCS" on page 4-26.



Brake disc deflection limit
0.1 mm (0.004 in)

4. Measure:
 - Brake disc thickness
Measure the brake disc thickness at a few different locations.
Out of specification → Replace.

Refer to "CHECKING THE FRONT BRAKE DISCS" on page 4-26.



Brake disc thickness limit
3.0 mm (0.12 in)

5. Adjust:
 - Brake disc deflection
Refer to "CHECKING THE FRONT BRAKE DISCS" on page 4-26.



Rear brake disc bolt
30 Nm (3.0 m·kg, 22 ft·lb)
LOCTITE®

6. Install:
 - Rear wheels
Refer to "REAR WHEELS" on page 4-18.

EAS22580

REPLACING THE REAR BRAKE PADS

TIP

When replacing the brake pads, it is not necessary to disconnect the brake hose or disassemble the brake caliper.

1. Measure:
 - Brake pad wear limit "a"
Out of specification → Replace the brake pads and brake pad spring as a set.



Brake pad lining thickness (inner)
5.8 mm (0.23 in)
Limit
1.0 mm (0.04 in)
Brake pad lining thickness (outer)
5.8 mm (0.23 in)
Limit
1.0 mm (0.04 in)

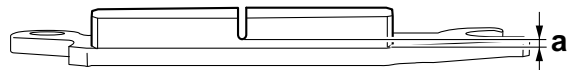

2. Install:
 - Brake pad spring
 - Brake pads

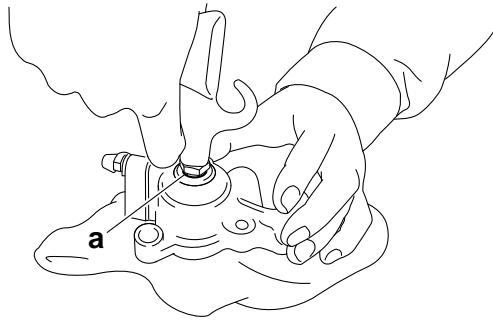

b. Remove the brake caliper dust seal and brake caliper piston seal.



EAS22640

CHECKING THE REAR BRAKE CALIPERS

The following procedure applies to both of the brake calipers.

Recommended brake component replacement schedule	
Brake pads	If necessary
Piston seals, dust seals	Every two years
Brake hoses	Every four years
Brake fluid	Every two years and whenever the brake is disassembled

1. Check:

- Brake caliper piston “1”
Rust/scratches/wear → Replace the brake caliper piston.
- Brake caliper cylinder “2”
Scratches/wear → Replace the brake caliper assembly.
- Brake caliper body “3”
Cracks/damage → Replace the brake caliper assembly.
- Brake fluid delivery passages (brake caliper body)
Obstruction → Blow out with compressed air.

EWA28P1002

WARNING

Whenever a brake caliper is disassembled, replace the brake caliper piston seals and dust seals.

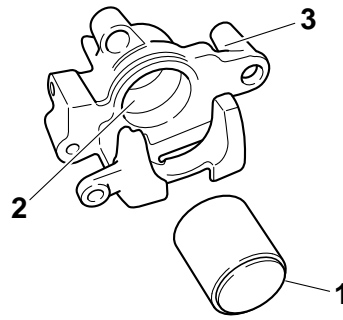

EAS22650

ASSEMBLING THE REAR BRAKE CALIPERS

The following procedure applies to both of the brake calipers.

EWA28P1003

WARNING

- Before installation, all internal brake components should be cleaned and lubricated with clean or new brake fluid.
- Never use solvents on internal brake components as they will cause the piston seals to swell and distort.
- Whenever a brake caliper is disassembled, replace the brake caliper piston seal and dust seal.

	Specified brake fluid DOT 4
---	--

EAS22670

INSTALLING THE REAR BRAKE CALIPERS

The following procedure applies to both of the brake calipers.

1. Install:

- Brake caliper assembly
- Brake caliper bolts “1”
- Brake hose “2”
- Copper washers “3” **New**
- Brake hose union bolt “4”

	Brake caliper bolt 30 Nm (3.0 m·kg, 22 ft·lb) Brake hose union bolt 27 Nm (2.7 m·kg, 19 ft·lb)
---	---

EWA13530

WARNING

Proper brake hose routing is essential to insure safe vehicle operation. Refer to “CABLE ROUTING” on page 2-31.

ECA28P1014

NOTICE

When installing the brake hose onto the brake caliper, make sure the brake pipe touches the projection “a” on the brake caliper.

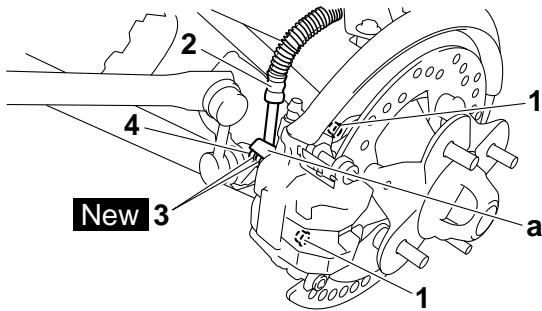

2. Fill:
 - Brake master cylinder reservoir (with the specified amount of the specified brake fluid)



**Specified brake fluid
DOT 4**

EWA13090

WARNING

- Use only the designated brake fluid. Other brake fluids may cause the rubber seals to deteriorate, causing leakage and poor brake performance.
- Refill with the same type of brake fluid that is already in the system. Mixing brake fluids may result in a harmful chemical reaction, leading to poor brake performance.
- When refilling, be careful that water does not enter the brake fluid reservoir. Water will significantly lower the boiling point of the brake fluid and could cause vapor lock.

ECA13540

NOTICE

Brake fluid may damage painted surfaces and plastic parts. Therefore, always clean up any spilled brake fluid immediately.

3. Bleed:
 - Brake system
Refer to “BLEEDING THE HYDRAULIC BRAKE SYSTEM” on page 3-22.
4. Check:
 - Brake fluid level
Below the minimum level mark → Add the specified brake fluid to the proper level.
Refer to “CHECKING THE BRAKE FLUID LEVEL” on page 3-20.

5. Check:
 - Brake lever and pedal operation
Soft or spongy feeling → Bleed the brake system.
Refer to “BLEEDING THE HYDRAULIC BRAKE SYSTEM” on page 3-22.

EAS22710

CHECKING THE REAR BRAKE MASTER CYLINDER

1. Check:
 - Brake master cylinder
Damage/scratches/wear → Replace.
 - Brake fluid delivery passages (brake master cylinder body)
Obstruction → Blow out with compressed air.
2. Check:
 - Brake master cylinder kit
Damage/scratches/wear → Replace.
3. Check:
 - Brake master cylinder reservoir
Cracks/damage → Replace.
 - Brake master cylinder reservoir diaphragm
Cracks/damage → Replace.
4. Check:
 - Brake hoses
Cracks/damage/wear → Replace.

EAS22730

ASSEMBLING THE REAR BRAKE MASTER CYLINDER

EWA28P1008

WARNING

- Before installation, all internal brake components should be cleaned and lubricated with clean or new brake fluid.
- Never use solvents on internal brake components.
- Whenever a master cylinder is disassembled, replace the brake master cylinder kit.



**Specified brake fluid
DOT 4**

EAS22750

INSTALLING THE REAR BRAKE MASTER CYLINDER

1. Install:
 - Brake master cylinder “1”
 - Brake master cylinder holder “2”

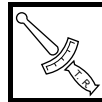

**Brake master cylinder holder bolt
7 Nm (0.7 m·kg, 5.1 ft·lb)**

REAR BRAKE

TIP

- Align the end of the brake master cylinder holder with the punch mark “a” on the handlebar.
- Install the brake master cylinder holder with the “UP” mark “b” facing up.
- Install the brake master cylinder holder so that the gaps between the brake master cylinder and the brake master cylinder holder are equal.

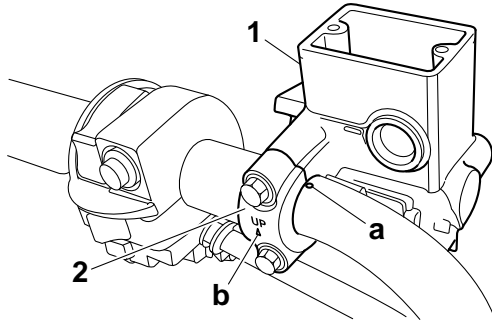

2. Install:

- Brake hose
- Copper washers **New**
- Brake hose union bolt



Brake hose union bolt
27 Nm (2.7 m·kg, 19 ft·lb)

EWA13530

⚠ WARNING

Proper brake hose routing is essential to insure safe vehicle operation. Refer to “CABLE ROUTING” on page 2-31.

TIP

- While holding the brake hose, tighten the union bolt as shown.
- Turn the handlebar to the left and right to make sure the brake hose does not touch other parts (e.g., wire harness, cables, leads). Correct if necessary.

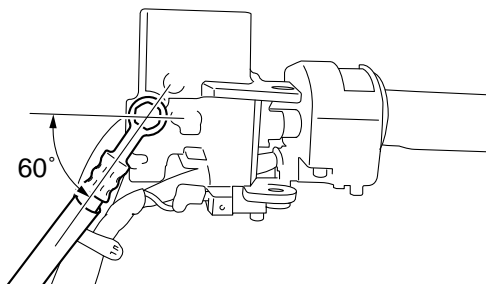

3. Install:

- Brake lever bracket

- Brake lever

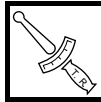

Brake lever pivot bolt
6 Nm (0.6 m·kg, 4.3 ft·lb)
Brake lever pivot nut
6 Nm (0.6 m·kg, 4.3 ft·lb)

ECA28P1007

NOTICE

The brake lever pivot bolt and nut have left-handed threads. To tighten the pivot bolt and nut, turn them counterclockwise.

4. Install:

- Rear brake lever cover “1”

TIP

Fit the holes in the rear brake lever cover over the bolt head “a” and nut “b”.

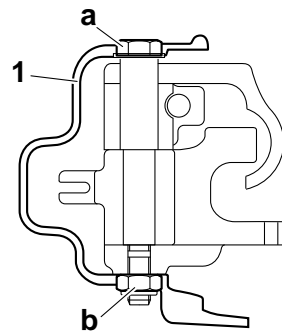

5. Fill:

- Brake master cylinder reservoir (with the specified amount of the specified brake fluid)



Specified brake fluid
DOT 4

EWA13540

⚠ WARNING

- Use only the designated brake fluid. Other brake fluids may cause the rubber seals to deteriorate, causing leakage and poor brake performance.
- Refill with the same type of brake fluid that is already in the system. Mixing brake fluids may result in a harmful chemical reaction, leading to poor brake performance.
- When refilling, be careful that water does not enter the brake master cylinder reservoir. Water will significantly lower the boiling point of the brake fluid and could cause vapor lock.

ECA13540

NOTICE

Brake fluid may damage painted surfaces and plastic parts. Therefore, always clean up any spilt brake fluid immediately.

6. Bleed:

- Brake system
Refer to "BLEEDING THE HYDRAULIC BRAKE SYSTEM" on page 3-22.

7. Check:

- Brake fluid level
Below the minimum level mark → Add the specified brake fluid to the proper level.
Refer to "CHECKING THE BRAKE FLUID LEVEL" on page 3-20.

8. Check:

- Brake lever and pedal operation
Soft or spongy feeling → Bleed the brake system.
Refer to "BLEEDING THE HYDRAULIC BRAKE SYSTEM" on page 3-22.

EAS22840

HANDLEBAR

Removing the handlebar

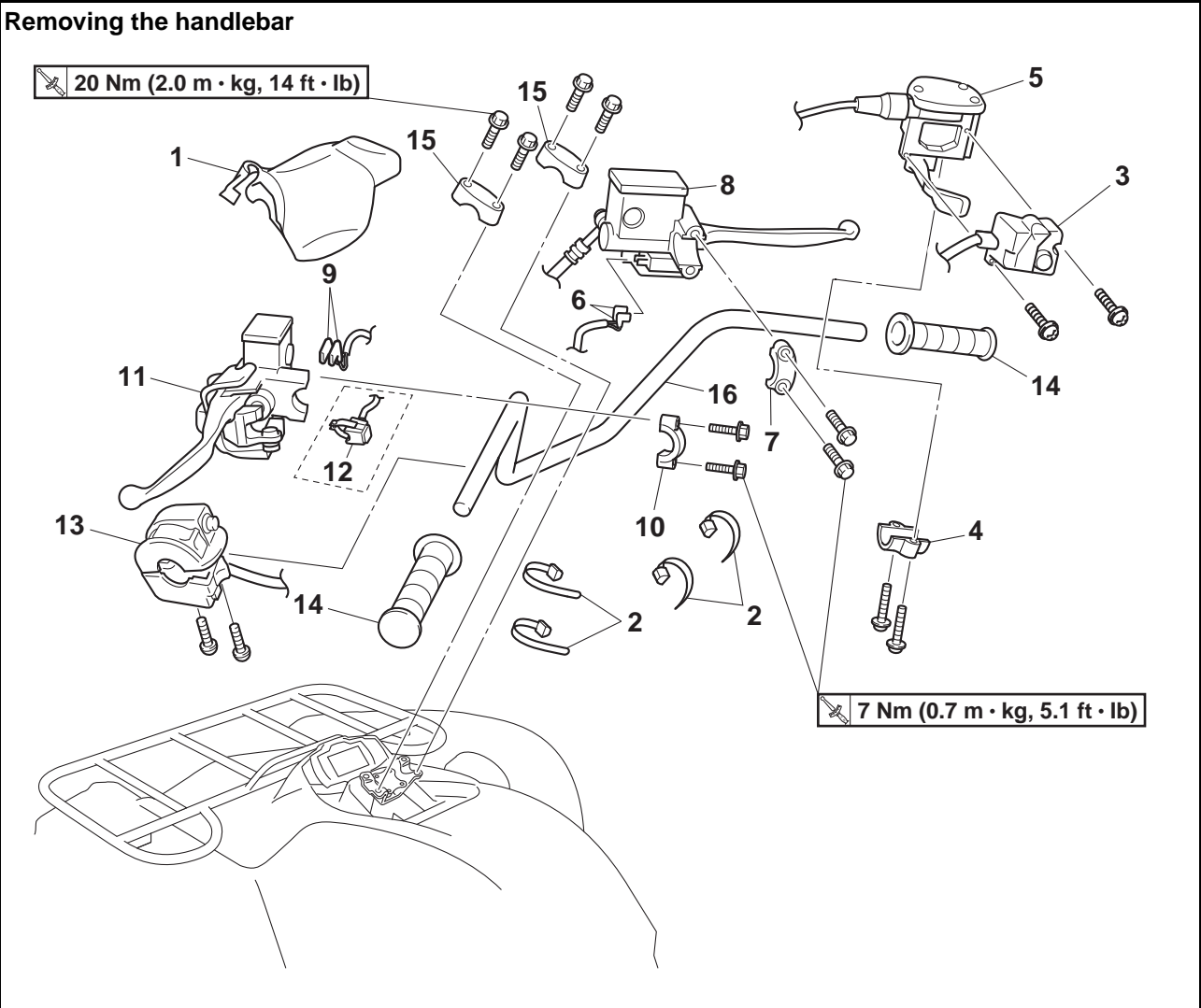



Order	Job/Parts to remove	Q'ty	Remarks
1	Handlebar cover	1	
2	Plastic band	4	
3	On-command four-wheel-drive motor switch and differential gear lock switch	1	
4	Throttle lever assembly holder	1	
5	Throttle lever assembly	1	
6	Front brake light switch connector	2	Disconnect.
7	Front brake master cylinder holder	1	
8	Front brake master cylinder	1	
9	Rear brake light switch connector	2	Disconnect.
10	Rear brake master cylinder holder	1	
11	Rear brake master cylinder	1	
12	Horn switch	1	For Europe and Oceania
13	Left handlebar switch	1	
14	Handlebar grip	2	
15	Handlebar holder	2	

HANDLEBAR

Removing the handlebar

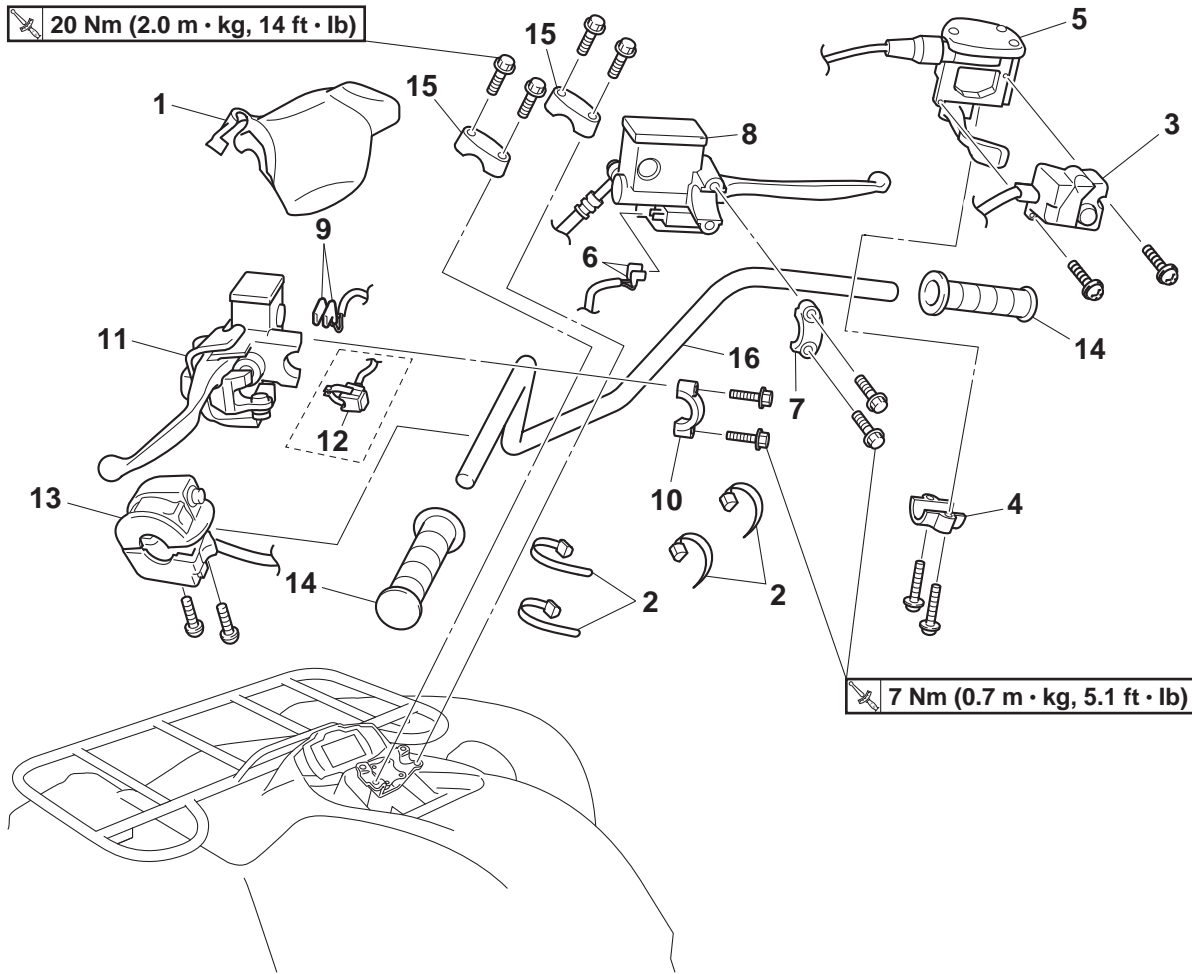
 20 Nm (2.0 m · kg, 14 ft · lb)



 7 Nm (0.7 m · kg, 5.1 ft · lb)

Order	Job/Parts to remove	Q'ty	Remarks
16	Handlebar	1	
			For installation, reverse the removal procedure.

EAS22860

REMOVING THE HANDLEBAR

1. Place the vehicle on a level surface.
2. Remove:
 - Handlebar grip "1"

TIP

Blow compressed air between the left handlebar end and the handlebar grip, and gradually push the grip off the handlebar.

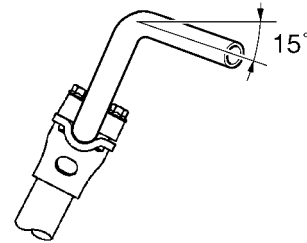
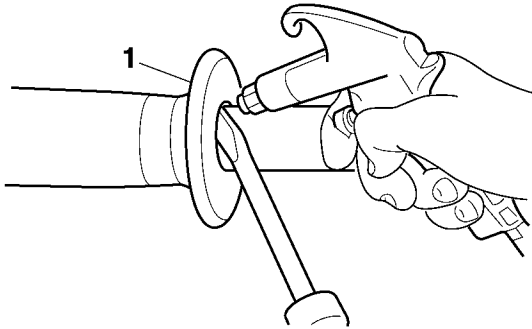

EAS22880

CHECKING THE HANDLEBAR

1. Check:
 - Handlebar
 - Bends/cracks/damage → Replace.

EWA13690

⚠ WARNING

Do not attempt to straighten a bent handlebar as this may dangerously weaken it.

EAS22940

INSTALLING THE HANDLEBAR

1. Place the vehicle on a level surface.
2. Install:
 - Handlebar
 - Handlebar holders



Handlebar holder bolt
20 Nm (2.0 m·kg, 14 ft·lb)

TIP

- Install the handlebar within 15° from the horizontal line shown in the illustration.
- The upper handlebar holders should be installed with the punch mark "a" forward "A".
- First tighten the bolts "1" on the front side of the handlebar holders, and then tighten the bolts "2" on the rear side.

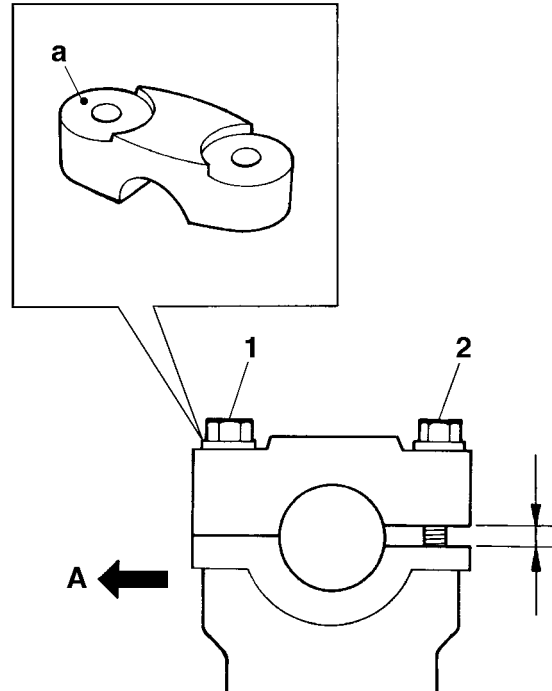

3. Install:
 - Handlebar grip "1"

- a. Wipe off grease or oil on the handlebar surface "a" with a lacquer thinner.
- b. Apply a thin coat of rubber adhesive onto the left and right ends of the handlebar.
- c. Install the handlebar grips to the handlebar so that arrow mark "L" faces up on the left handlebar grip and the arrow mark "R" faces up on the right handlebar.
- d. Wipe off any excess rubber adhesive with a clean rag.

EWA13700

⚠ WARNING

Do not touch the handlebar grip until the rubber adhesive has fully dried.

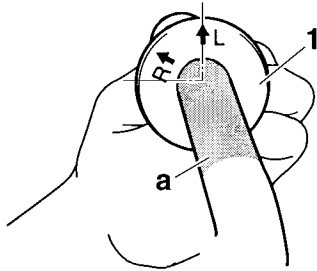

4. Install:

- Left handlebar switch
- Rear brake master cylinder "1"
- Rear brake master cylinder holder "2"



Rear brake master cylinder holder bolt
7 Nm (0.7 m·kg, 5.1 ft·lb)

TIP

- Align the end of the brake master cylinder holder with the punch mark "a" on the handlebar.
- The "UP" mark "b" on the brake master cylinder holder should face up.
- Install the brake master cylinder holder so that the gaps between the brake master cylinder and the brake master cylinder holder are equal.

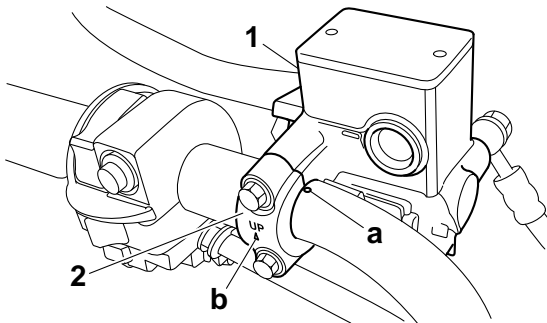

5. Install: (for Europe and Oceania)

- Horn switch "1"

TIP

Be sure to fit the projection "a" on the handlebar "2" between the ends of the horn switch.

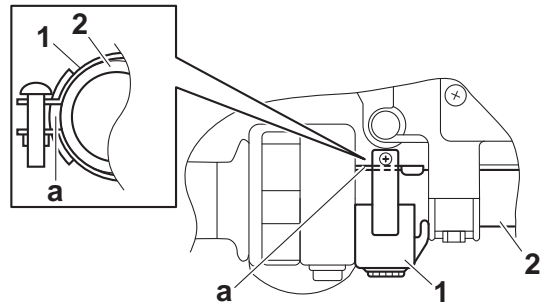

6. Install:

- Front brake master cylinder "1"
- Front brake master cylinder holder "2"



Front brake master cylinder holder bolt
7 Nm (0.7 m·kg, 5.1 ft·lb)

TIP

- Align the end of the brake master cylinder holder with the punch mark "a" on the handlebar.
- The "UP" mark "b" on the brake master cylinder holder should face up.
- Install the brake master cylinder holder so that the gaps between the brake master cylinder and the brake master cylinder holder are equal.

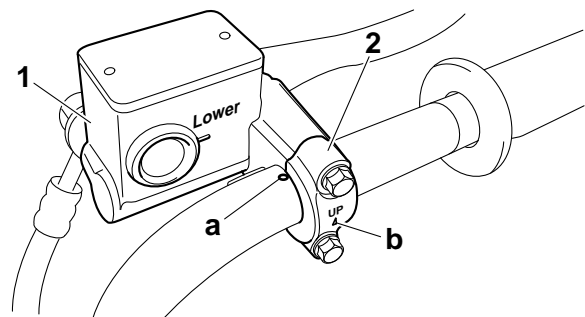

7. Install:

- Throttle lever assembly "1"
- Throttle lever assembly holder

TIP

Align the projection "a" on the throttle lever assembly with the end of the brake master cylinder holder "b".

HANDLEBAR

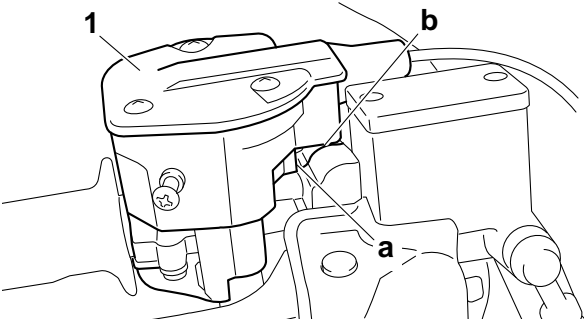

EAS29540

STEERING STEM

Removing the steering stem (except for EPS models)

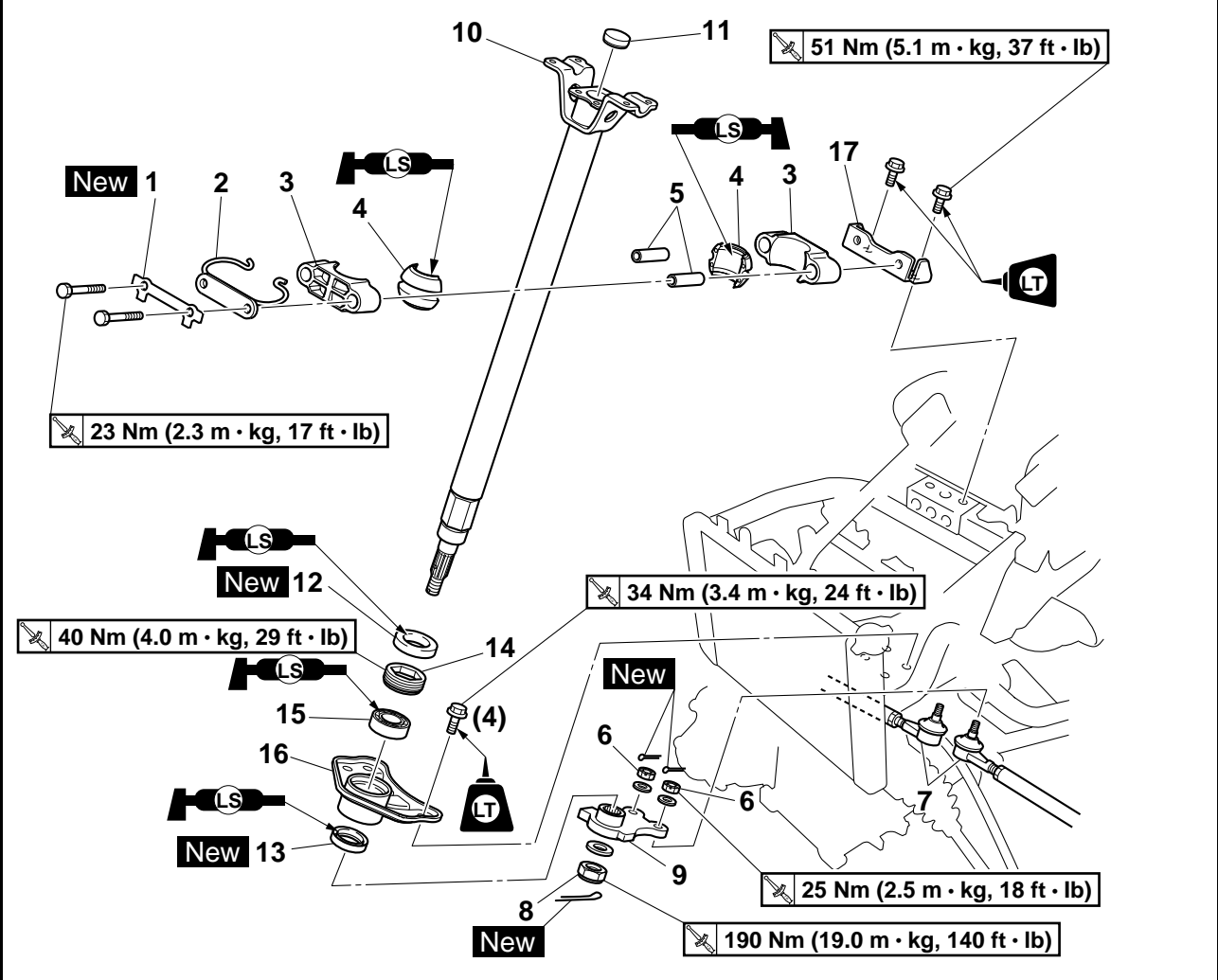

Order	Job/Parts to remove	Q'ty	Remarks
	Front fender/Air filter case/Electrical components tray		Refer to "GENERAL CHASSIS" on page 4-1.
	Handlebar		Refer to "HANDLEBAR" on page 4-44.
1	Lock washer	1	
2	Cable guide	1	
3	Steering stem bushing holder	2	
4	Steering stem bushing	2	
5	Collar	2	
6	Tie-rod nut	2	
7	Tie-rod	2	Disconnect.
8	Pitman arm nut	1	
9	Pitman arm	1	
10	Steering stem	1	
11	Plug	1	
12	Oil seal	1	
13	Oil seal	1	

STEERING STEM

Removing the steering stem (except for EPS models)

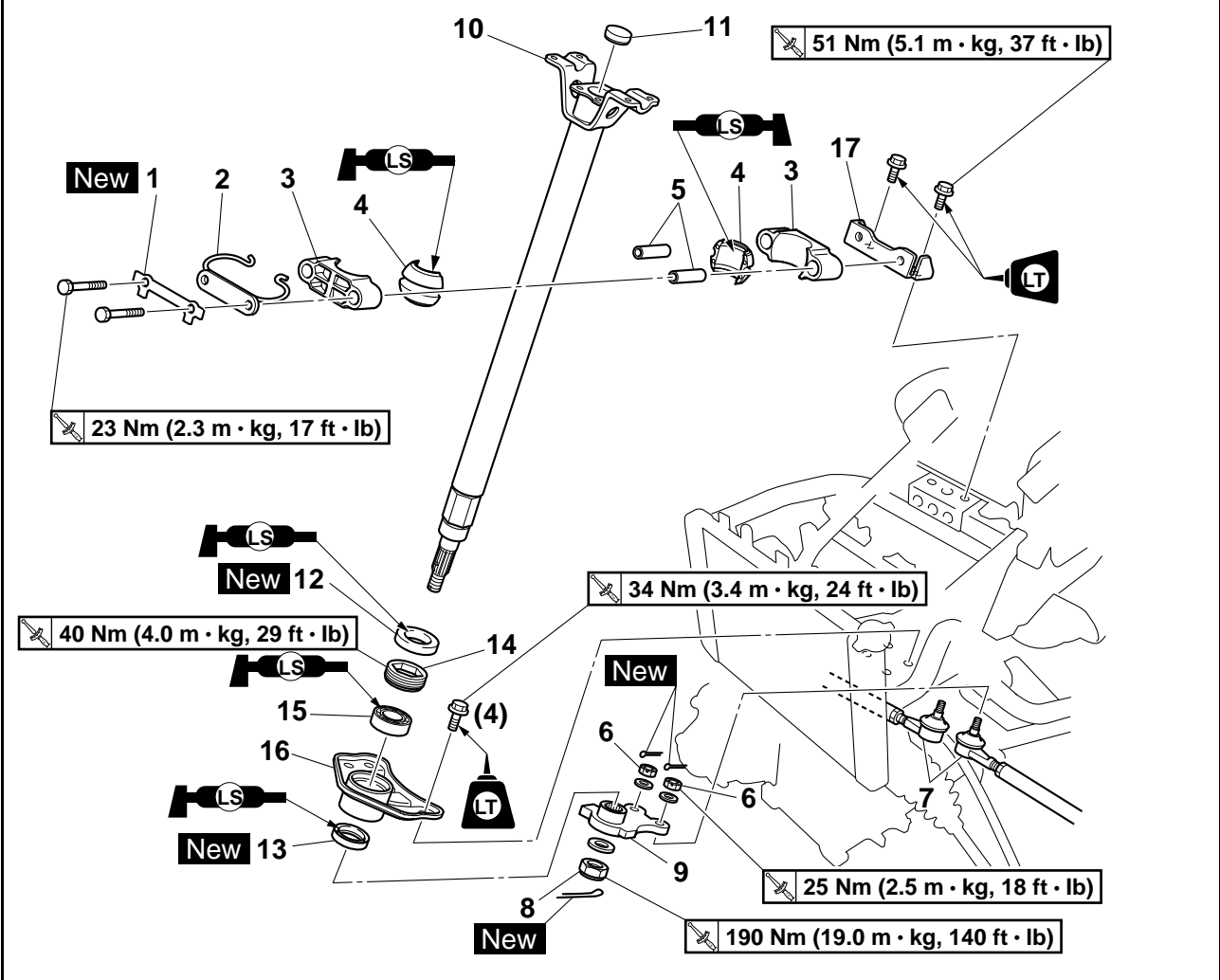

Order	Job/Parts to remove	Q'ty	Remarks
14	Bearing retainer	1	
15	Bearing	1	
16	Steering stem support	1	
17	Steering stem bracket	1	
			For installation, reverse the removal procedure.

STEERING STEM

Removing the steering stem (for EPS models)

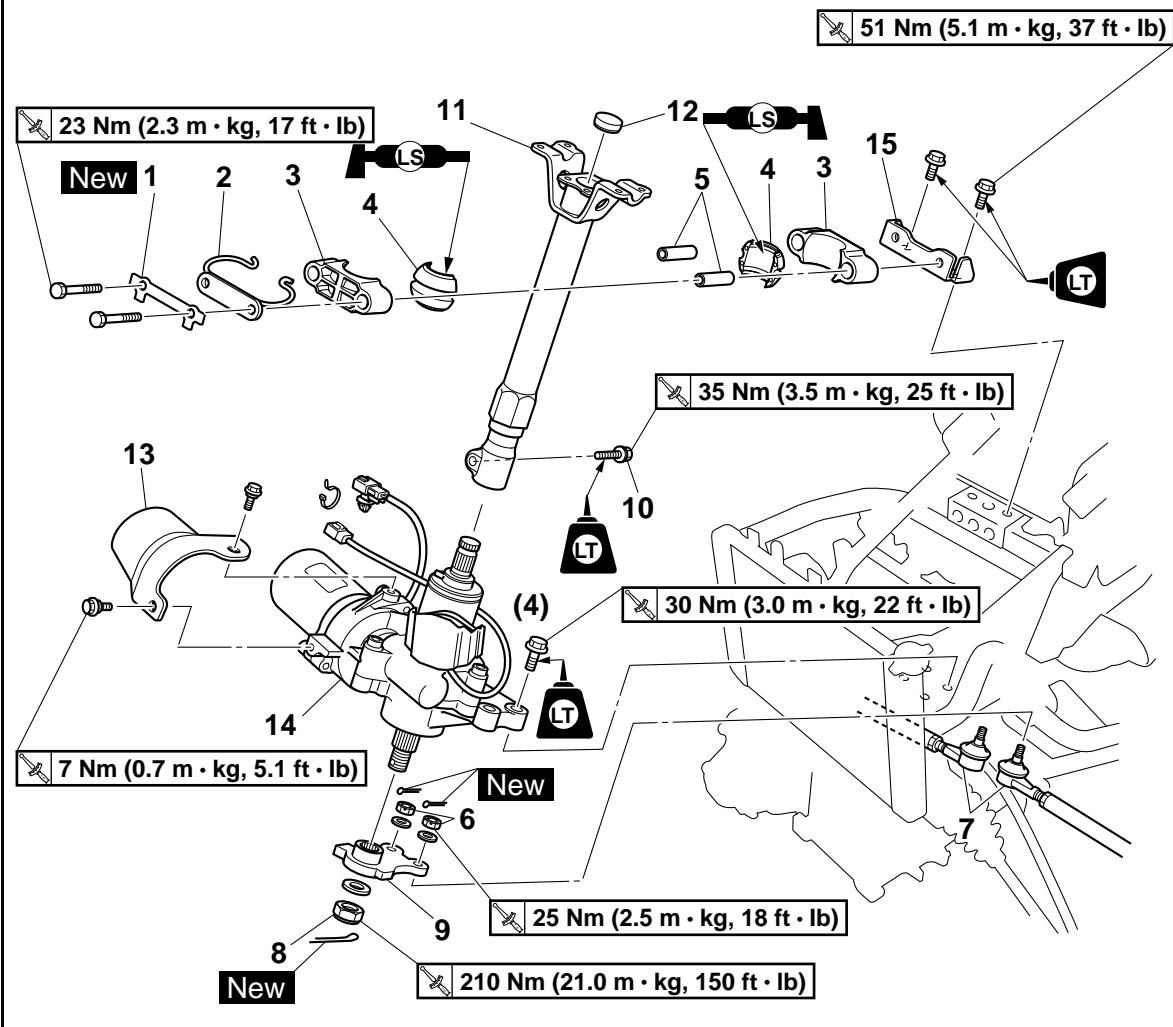

Order	Job/Parts to remove	Q'ty	Remarks
	Front fender/Air filter case/Electrical components tray		Refer to "GENERAL CHASSIS" on page 4-1.
	Handlebar		Refer to "HANDLEBAR" on page 4-44.
1	Lock washer	1	
2	Cable guide	1	
3	Steering stem bushing holder	2	
4	Steering stem bushing	2	
5	Collar	2	
6	Tie-rod nut	2	
7	Tie-rod	2	Disconnect.
8	Pitman arm nut	1	
9	Pitman arm	1	
10	Steering stem pinch bolt	1	
11	Steering stem	1	
12	Plug	1	
13	EPS motor cover	1	

STEERING STEM

Removing the steering stem (for EPS models)

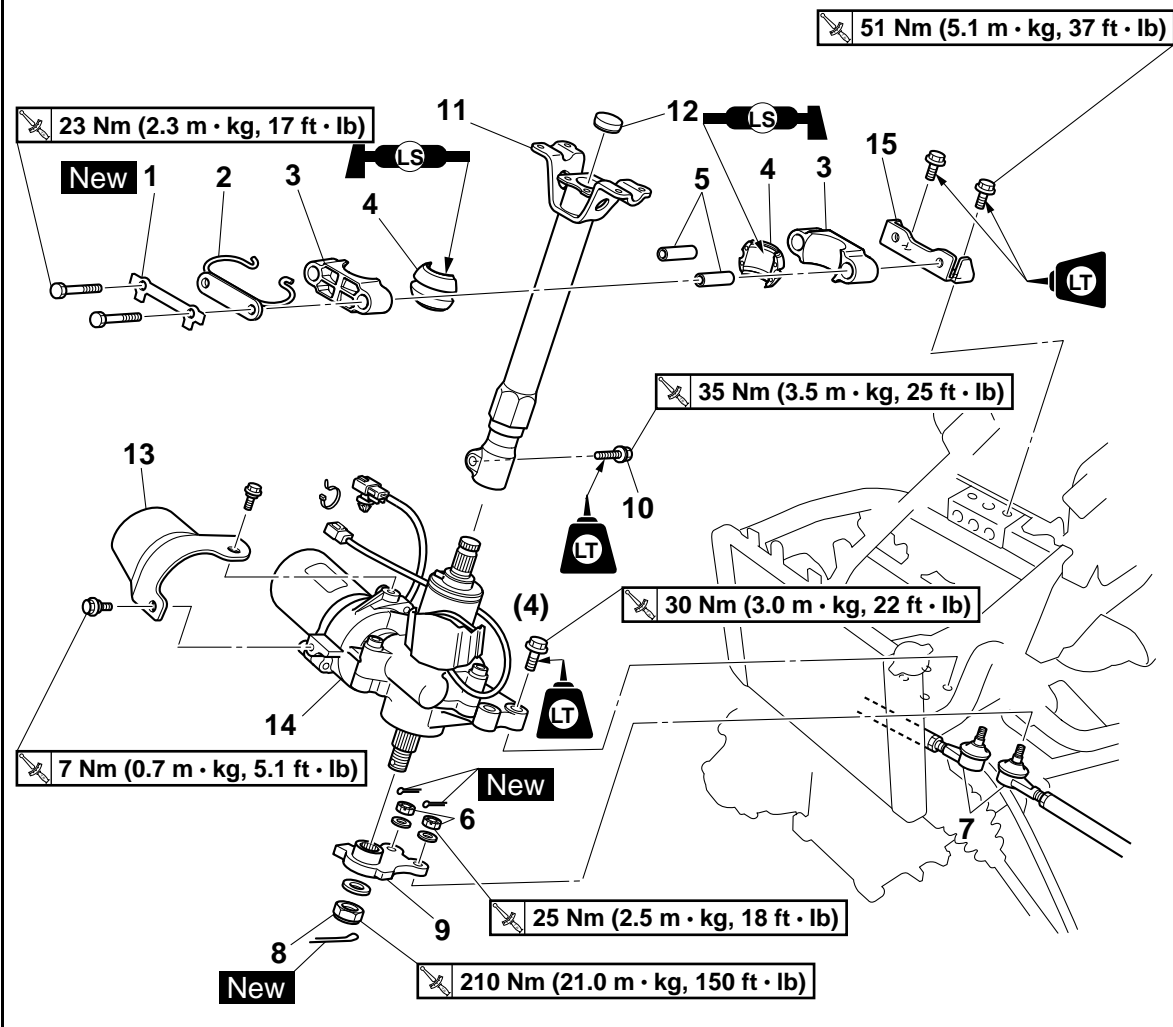

Order	Job/Parts to remove	Q'ty	Remarks
14	EPS unit	1	ECA28P1008 NOTICE _____ The EPS unit should not be disassembled.
15	Steering stem bracket	1	
			For installation, reverse the removal procedure.

EAS1HPG003

REMOVING THE BEARING RETAINER (except for EPS models)

1. Remove:
 - Bearing retainer "1"

TIP

Remove the bearing retainer with the damper rod holder "2".



Damper rod holder (30 mm)
90890-01327
YM-01327

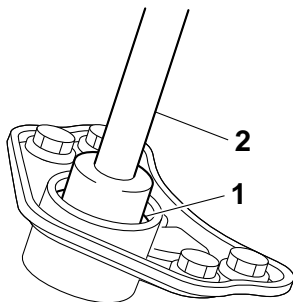

EAS29560

CHECKING THE STEERING STEM

1. Check:
 - Steering stem
 - Bends → Replace.

EWA15030



WARNING

Do not attempt to straighten a bent stem; this may dangerously weaken the stem.

2. Check:
 - Steering stem bushings
 - Wear/damage → Replace.

EAS1HPG001

INSTALLING THE STEERING STEM (except for EPS models)

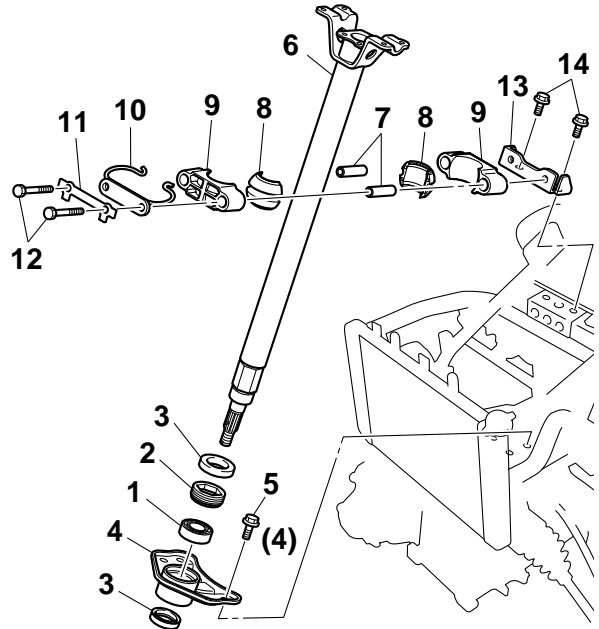

1. Install:
 - Bearing "1"
 - Bearing retainer "2"
 - Oil seals "3" **New**



Bearing retainer
40 Nm (4.0 m·kg, 29 ft·lb)

TIP

Install the bearing retainer with the damper rod holder.



Damper rod holder (30 mm)
90890-01327
YM-01327

2. Install:
 - Steering stem support "4"
 - Steering stem support bolts "5" (temporarily tighten)
3. Install:
 - Steering stem "6"
4. Install:
 - Collars "7"
 - Steering stem bushings "8"
 - Steering stem bushing holders "9"
 - Cable guide "10"
 - Lock washer "11" **New**

STEERING STEM

- Steering stem bolts “12”
(temporarily tighten)

TIP

Apply lithium-soap-based grease to the steering stem bushings.

5. Install:

- Steering stem bracket “13”
- Steering stem bracket bolts “14”
(temporarily tighten)

6. Tighten:

- Steering stem bolts “12”



Steering stem bolt
23 Nm (2.3 m·kg, 17 ft·lb)

TIP

- Bend the lock washer tabs “a” along a flat side of the bolts.
- Pass the brake hoses through the cable guide. Refer to “CABLE ROUTING” on page 2-31.

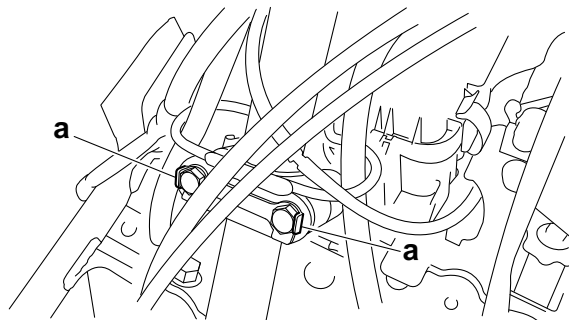

7. Tighten:

- Steering stem support bolts “5”



Steering stem support bolt
34 Nm (3.4 m·kg, 24 ft·lb)
LOCTITE®

8. Tighten:

- Steering stem bracket bolts “14”



Steering stem bracket bolt
51 Nm (5.1 m·kg, 37 ft·lb)
LOCTITE®

EAS28P1015

INSTALLING THE STEERING STEM (for EPS models)

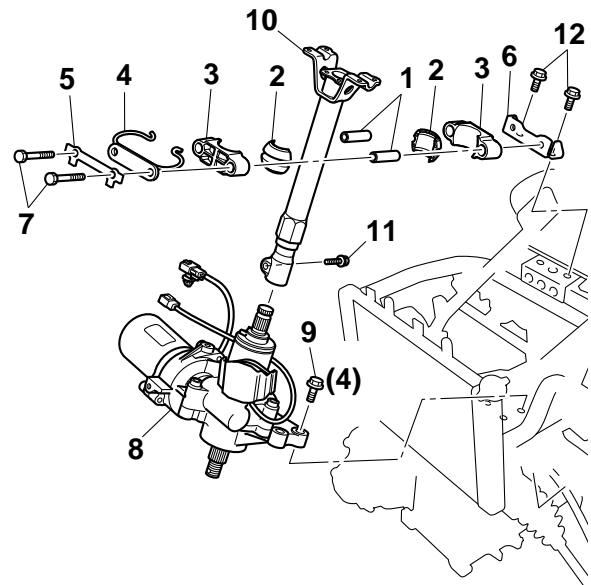

1. Install:

- Collars “1”
- Steering stem bushings “2”
- Steering stem bushing holders “3”
- Cable guide “4”
- Lock washer “5” **New**
- Steering stem bracket “6”
- Steering stem bolts “7”
(temporarily tighten)

TIP

Apply lithium-soap-based grease to the steering stem bushings.

2. Install:

- EPS unit “8”
- EPS unit bolts “9”
(temporarily tighten)

3. Install:

- Steering stem “10”
- Steering stem pinch bolt “11”
(temporarily tighten)

TIP

Align the punch mark “a” on the EPS unit with the groove “b” in the steering stem.

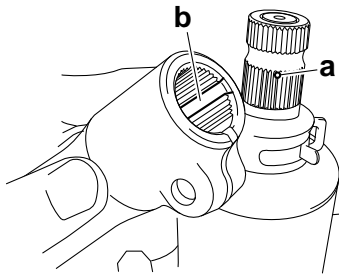

4. Install:
 - Steering stem bracket bolts "12" (temporarily tighten)
5. Tighten:
 - EPS unit bolts "9"
 - Steering stem pinch bolts "11"

	EPS unit bolt 30 Nm (3.0 m·kg, 22 ft·lb) LOCTITE® Steering stem pinch bolt 35 Nm (3.5 m·kg, 25 ft·lb) LOCTITE®
---	---

6. Tighten:
 - Steering stem bolts "7"

	Steering stem bolt 23 Nm (2.3 m·kg, 17 ft·lb)
---	--

- TIP** _____
- Bend the lock washer tabs "c" along a flat side of the bolts.
 - Pass the brake hoses through the cable guide. Refer to "CABLE ROUTING" on page 2-31.

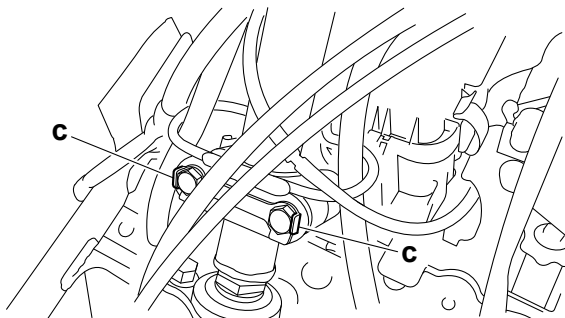

7. Tighten
 - Steering stem bracket bolts "12"

	Steering stem bracket bolt 51 Nm (5.1 m·kg, 37 ft·lb) LOCTITE®
---	---

EAS1HPG002

INSTALLING THE PITMAN ARM (except for EPS models)

1. Install:
 - Pitman arm "1"
 - Washer
 - Pitman arm nut
 - Cotter pin **New**

	Pitman arm nut 190 Nm (19.0 m·kg, 140 ft·lb)
---	---

- TIP** _____
- Align the groove "a" in the pitman arm with the steering stem spline "b" that is indented.

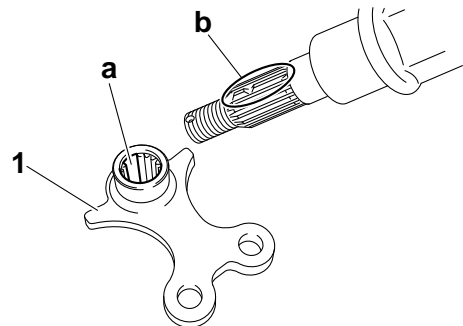

EAS29590

INSTALLING THE PITMAN ARM (for EPS models)

1. Install:
 - Pitman arm "1"
 - Washer
 - Pitman arm nut
 - Cotter pin **New**

	Pitman arm nut 210 Nm (21.0 m·kg, 150 ft·lb)
---	---

- TIP** _____
- Align the punch mark "a" on the EPS unit with the groove "b" in the pitman arm.

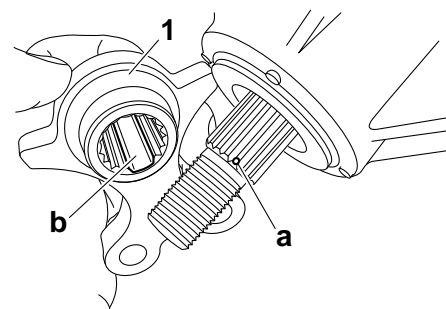

TIE-RODS AND STEERING KNUCKLES

EAS29660

TIE-RODS AND STEERING KNUCKLES

Removing the tie-rods and steering knuckles

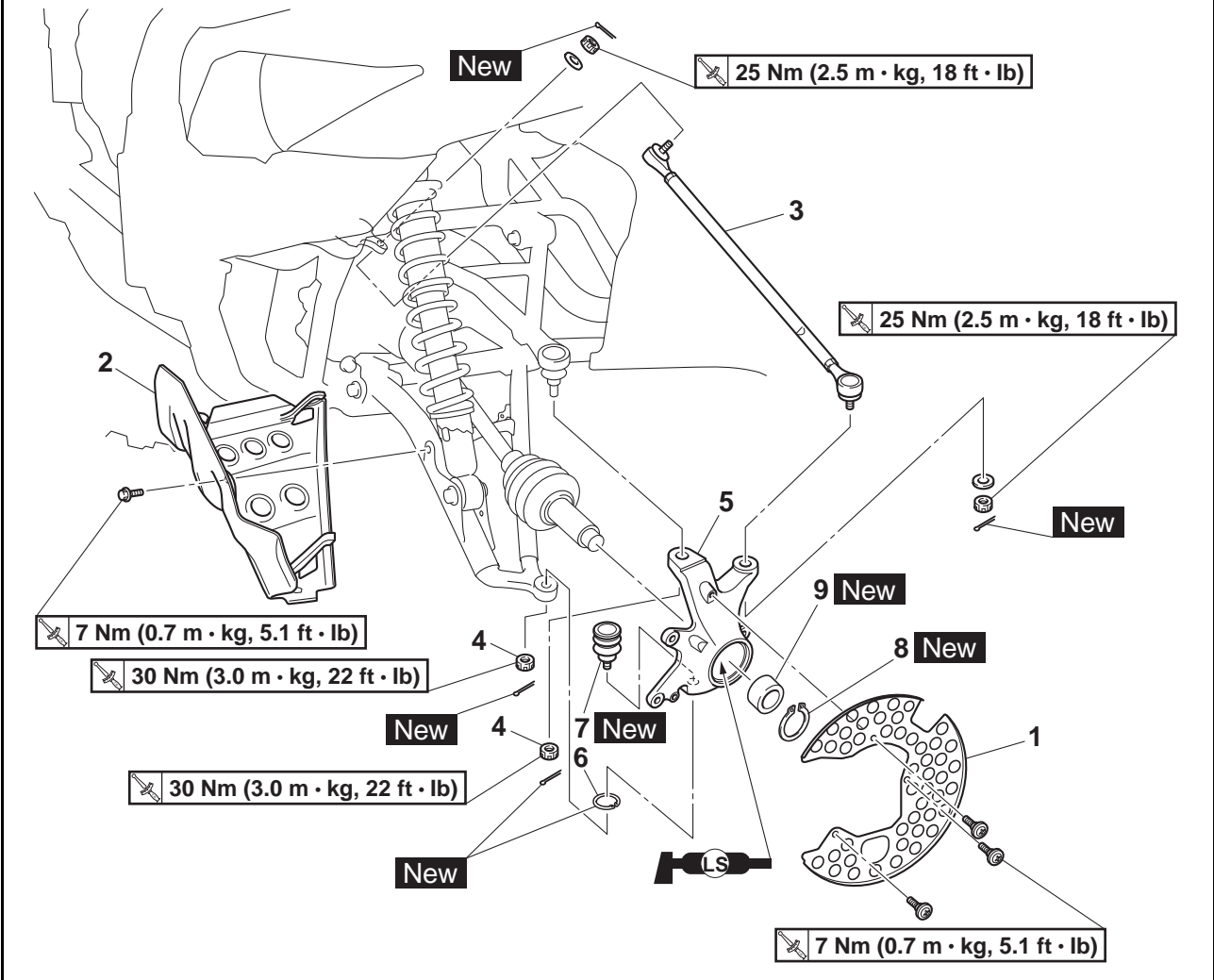

Order	Job/Parts to remove	Q'ty	Remarks
			The following procedure applies to both of the tie-rods and steering knuckles.
	Front wheel hub		Refer to "FRONT WHEELS" on page 4-14.
1	Brake disc guard	1	
2	Front arm protector	1	
3	Tie-rod	1	
4	Nut	2	
5	Steering knuckle	1	
6	Circlip	1	
7	Ball joint	1	
8	Circlip	1	
9	Wheel bearing	1	
			For installation, reverse the removal procedure.

TIE-RODS AND STEERING KNUCKLES

EAS29670

REMOVING THE STEERING KNUCKLES

The following procedure applies to both of the steering knuckles.

1. Remove:
 - Steering knuckle "1"

TIP

Use a general puller to separate the ball joints "2" from the steering knuckle "1" or the front lower arm "3".

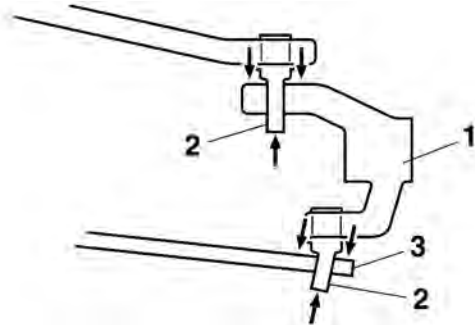

EAS29680

CHECKING THE TIE-RODS

The following procedure applies to both of the tie-rods.

1. Check:
 - Tie-rod movement
Rough movement → Replace the tie-rod end.
2. Check:
 - Tie-rod
Bends/damage → Replace.
Rubber boot damage → Replace the tie-rod end.

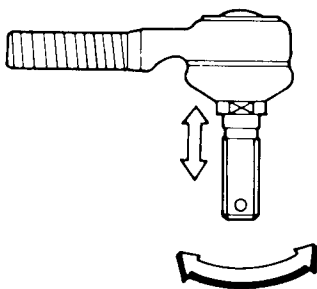

EAS29690

CHECKING THE STEERING KNUCKLES AND FRONT WHEEL BEARINGS

The following procedure applies to both of the steering knuckles and front wheel bearings.

1. Check:
 - Steering knuckle
Damage/pitting → Replace.

2. Check:
 - Front wheel bearing "1"
Rough movement/excessive free play → Replace.



- a. Clean the surface of the steering knuckle.
- b. Remove the circlip "2".
- c. Drive out the bearing.

EWA15040

WARNING

Eye protection is recommended when using striking tools.

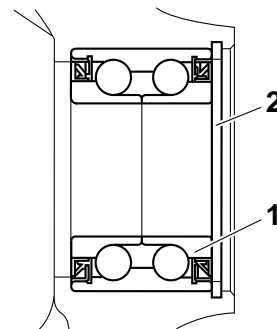

- d. Apply lithium-soap-based grease to the balls of the new bearing.
- e. Install the new bearing.

ECA16190

NOTICE

Do not strike the center race or balls of the bearing. Contact should be made only with the outer race.

- f. Install a new circlip.



EAS28P1030

CHECKING THE STEERING KNUCKLE BALL JOINTS

The following procedure applies to both of the steering knuckle ball joints.

1. Check:
 - Ball joint (steering knuckle)
Damage/pitting → Replace the ball joint.
Rubber boot damage → Replace the ball joint.
Rough movement → Replace the ball joint.

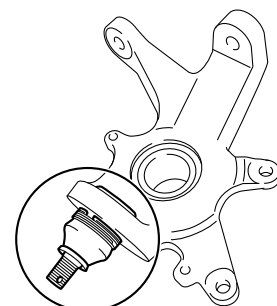

TIE-RODS AND STEERING KNUCKLES

- a. Clean the surface of the steering knuckle.
- b. Remove the circlip "1".

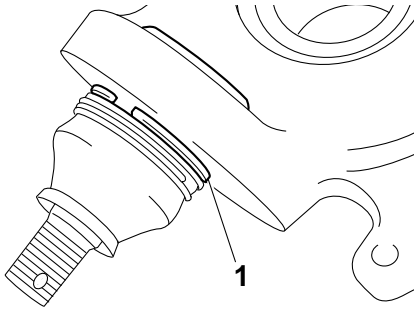

- c. Remove the ball joint "2".

TIP

Use a ball joint remover "3" to separate the ball joint "2" from the steering knuckle "4".

Ball joint remover
90890-01474
YM-01474

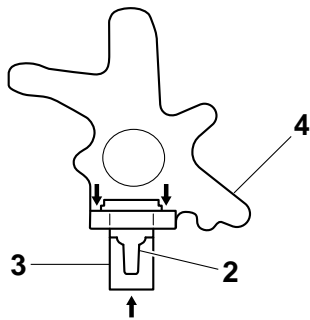

- d. Measure the ball joint bore inside diameter "a".
Out of specification → Replace the steering knuckle.

Ball joint bore inside diameter
32.45–32.50 mm (1.278–1.280 in)

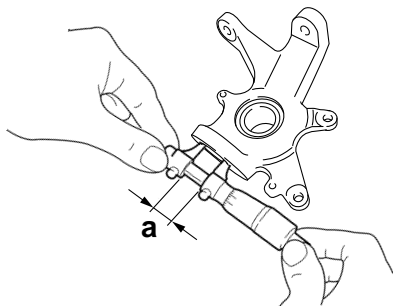

- e. Attach the special tools and new ball joint "5" to the steering knuckle "4".

TIP

- Always use a new ball joint.
- Do not tap or damage the top of the ball joint.

Ball joint remover
90890-01474
YM-01474
Ball joint remover attachment set
90890-01480
Ball joint adapter set
YM-01480
Ball joint remover short shaft set
90890-01514
YM-01514

No.	Tool name	Tool No.
6	Body	90890-01474 YM-01474
7	Installer spacer	90890-01480 YM-01480
8	Installer washer	
9	Base	
10	Guide bolt	90890-01514 YM-01514
11	Short bolt	

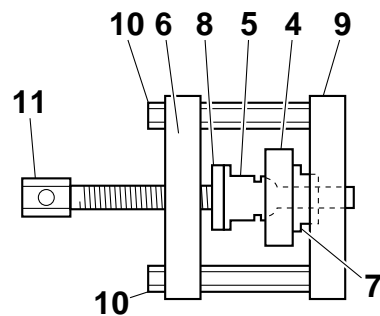
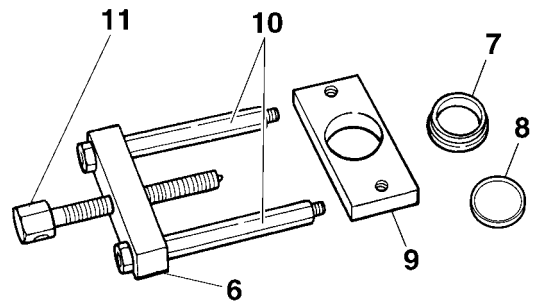

- f. Hold the base "9" in place while turning in the short bolt "11" to install the new ball joint "5" into the steering knuckle "4".
- g. Remove the special tools.
- h. Install a new circlip.

FRONT ARMS AND FRONT SHOCK ABSORBER ASSEMBLIES

EAS29710

FRONT ARMS AND FRONT SHOCK ABSORBER ASSEMBLIES

Removing the front arms and front shock absorber assemblies

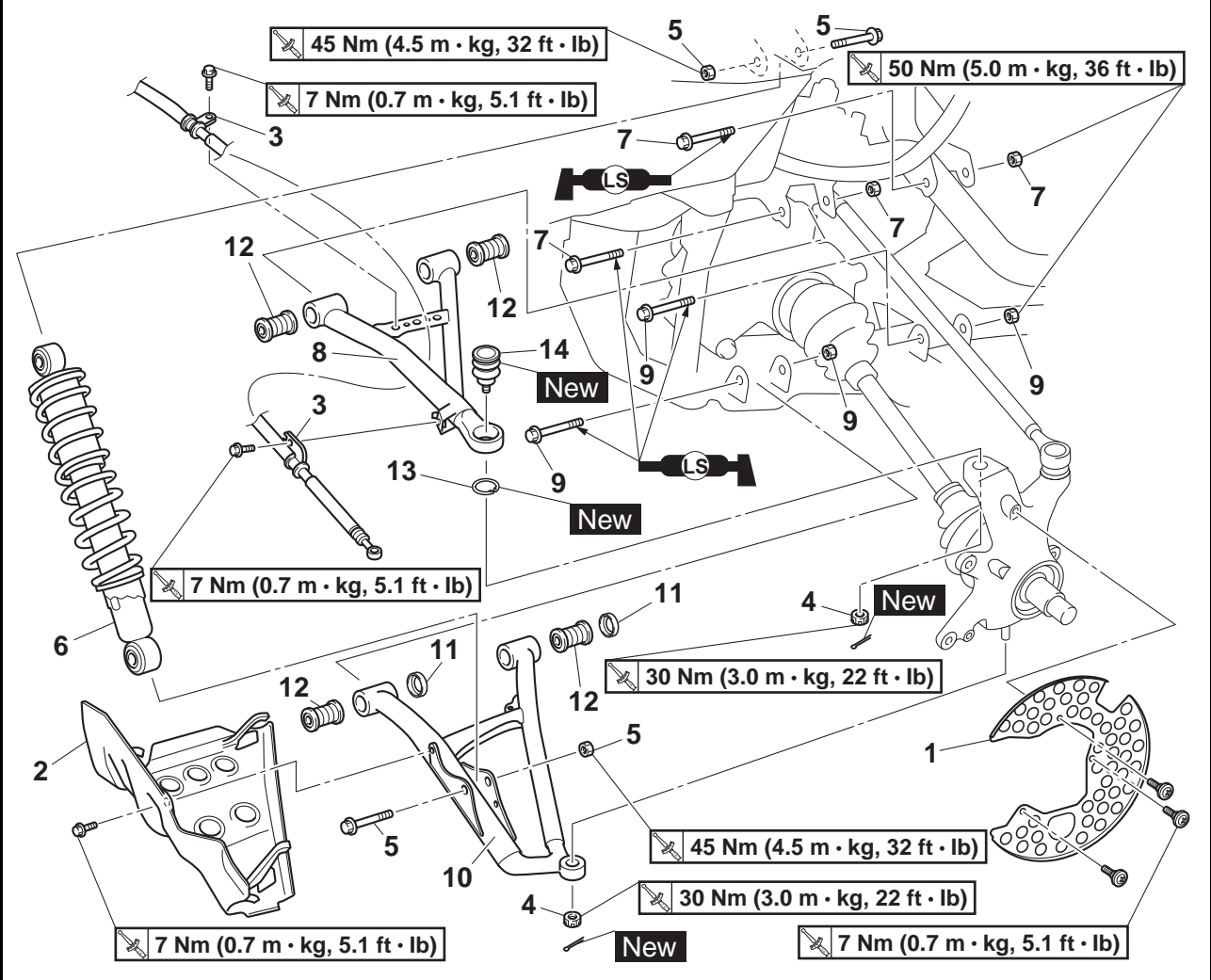

Order	Job/Parts to remove	Q'ty	Remarks
			The following procedure applies to both of the front upper arms, front lower arms, and front shock absorber assemblies.
	Front wheel hub		Refer to "FRONT WHEELS" on page 4-14.
	Front brake caliper assembly		Refer to "FRONT BRAKE" on page 4-21.
1	Brake disc guard	1	
2	Front arm protector	1	
3	Front brake hose holder	2	
4	Nut	2	
5	Nut/Bolt	2/2	
6	Front shock absorber assembly	1	
7	Nut/Bolt	2/2	
8	Front upper arm	1	
9	Nut/Bolt	2/2	
10	Front lower arm	1	
11	Dust cover	2	
12	Bushing	4	

FRONT ARMS AND FRONT SHOCK ABSORBER ASSEMBLIES

Removing the front arms and front shock absorber assemblies

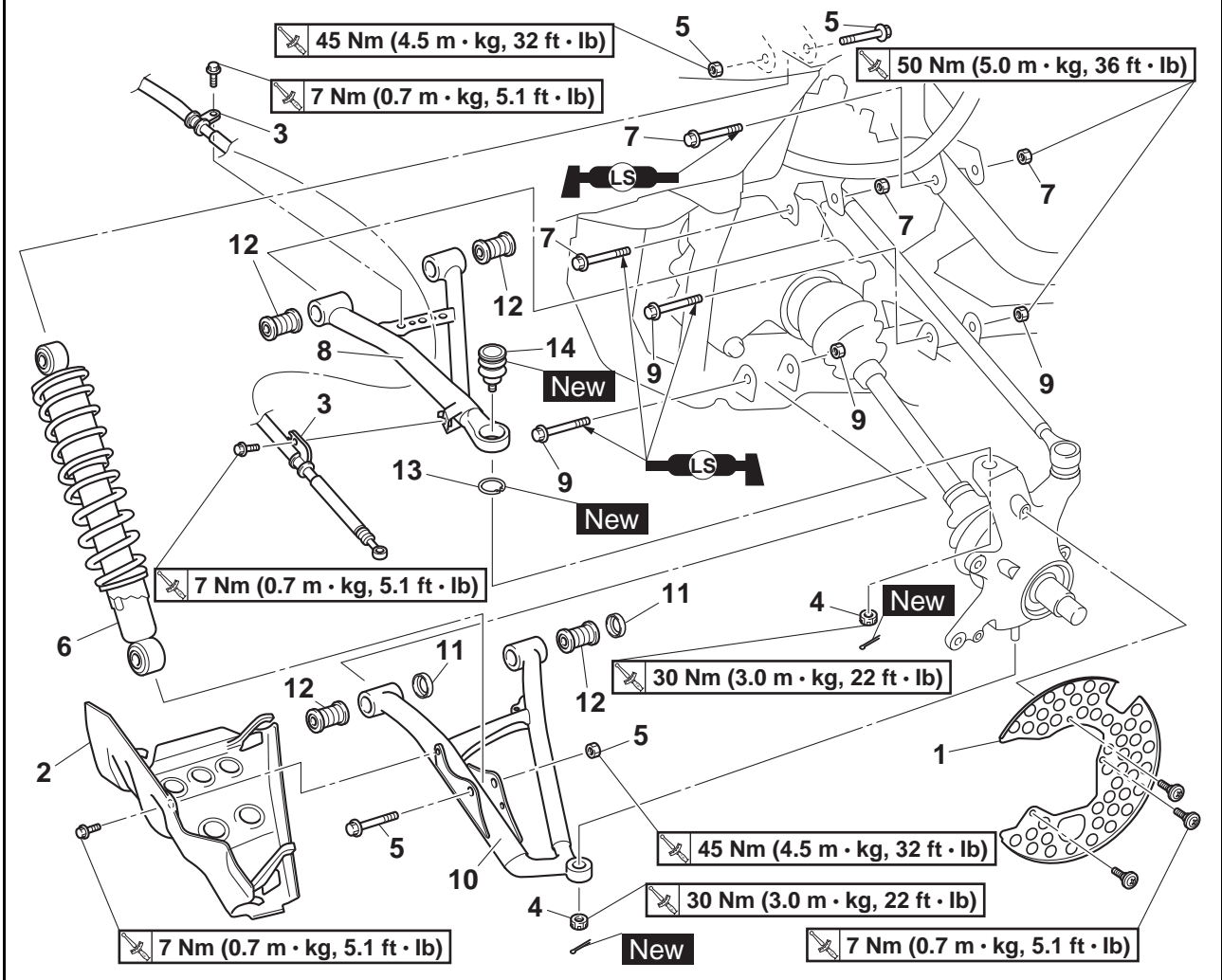

Order	Job/Parts to remove	Q'ty	Remarks
13	Circlip	1	
14	Ball joint	1	
			For installation, reverse the removal procedure.

FRONT ARMS AND FRONT SHOCK ABSORBER ASSEMBLIES

EAS29730

CHECKING THE FRONT ARMS

The following procedure applies to both of the front upper arms and front lower arms.

1. Check:

- Front arm free play

a. Check the front arm side play "A" by moving it from side to side.

If side play is noticeable, check the bushings.

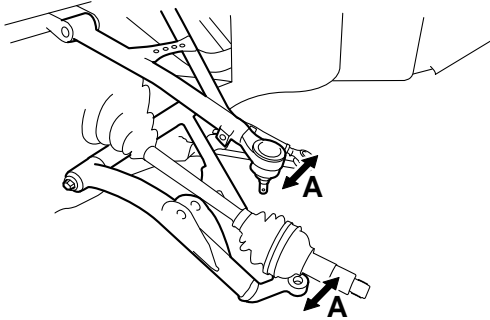

b. Check the front arm vertical movement "B" by moving it up and down.

If the vertical movement is tight or rough, or if there is binding, check the bushings.

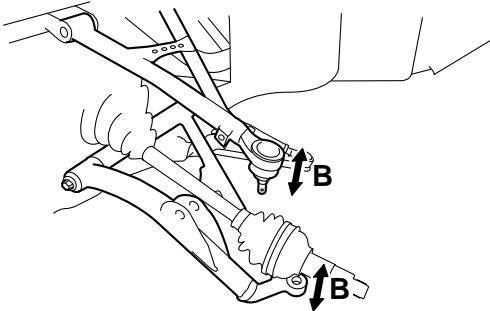

2. Check:

- Front upper arm
 - Front lower arm
- Bends/damage → Replace.

3. Check:

- Bushings
- Wear/damage → Replace.

EAS29760

CHECKING THE FRONT SHOCK ABSORBER ASSEMBLIES

The following procedure applies to both of the front shock absorber assemblies.

1. Check:

- Front shock absorber assembly
- Oil leaks → Replace the front shock absorber assembly.

- Front shock absorber rod
- Bends/damage → Replace the front shock absorber assembly.

• Spring

Move the spring up and down.

Fatigue → Replace the front shock absorber assembly.

EAS29770

CHECKING THE FRONT ARM BALL JOINTS

The following procedure applies to both of the front arm ball joints.

1. Check:

- Ball joint (front upper arm)

Damage/pitting → Replace the ball joint.

Rubber boot damage → Replace the ball joint.

Rough movement → Replace the ball joint.

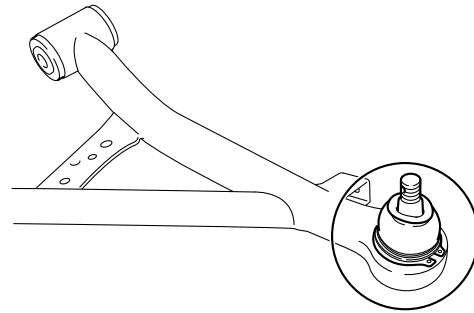

a. Clean the surface of the front upper arm.

b. Remove the circlip "1".

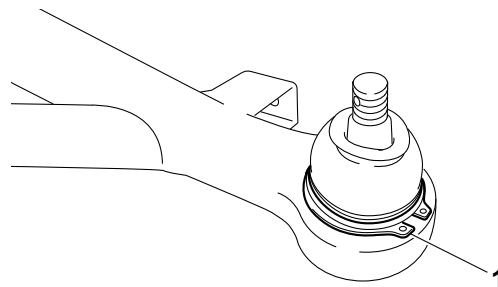

c. Attach the special tools to the ball joint (front upper arm) "2".



Ball joint remover

90890-01474

YM-01474

Ball joint remover attachment set

90890-01480

Ball joint adapter set

YM-01480

FRONT ARMS AND FRONT SHOCK ABSORBER ASSEMBLIES

No.	Tool name	Tool No.
3	Long bolt	90890-01474 YM-01474
4	Body	
5	Guide bolt	
6	Remover attachment	90890-01480 YM-01480
7	Installer spacer	
8	Installer washer	
9	Base	

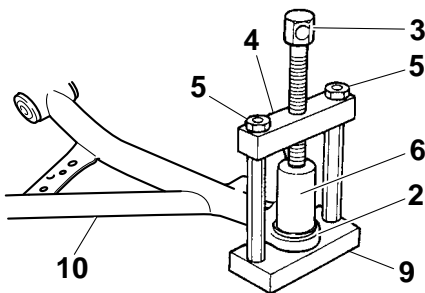
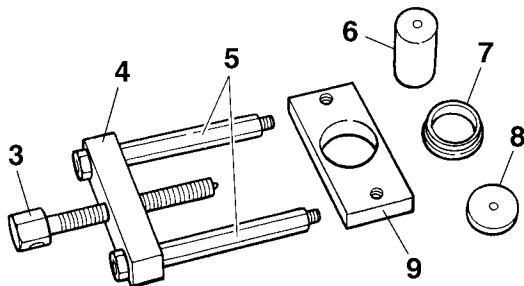

- d. Hold the base “9” in place while turning in the long bolt “3” to remove the ball joint “2” from the front upper arm “10”.
- e. Remove the special tools.
- f. Attach the special tools and new ball joint “11” to the front upper arm “10”.

TIP

- Always use a new ball joint.
- Do not tap or damage the top of the ball joint.

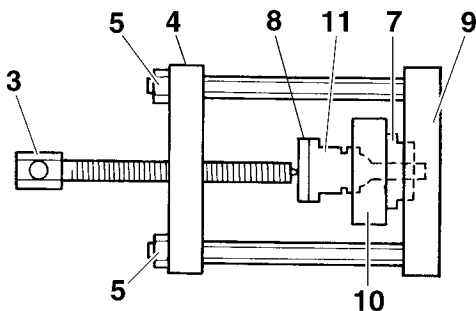

- g. Hold the base “9” in place while turning in the long bolt “3” to install the new ball joint “11” into the front upper arm “10”.
- h. Remove the special tools.
- i. Install a new circlip.



EAS29790

INSTALLING THE FRONT ARMS AND FRONT SHOCK ABSORBER ASSEMBLIES

The following procedure applies to both of the front upper arms, front lower arms, and front shock absorber assemblies.

1. Install:
- Front upper arm
 - Front lower arm
 - Front shock absorber assembly



- a. Install the front upper arm “1” and front lower arm “2”.

TIP

- Lubricate the front upper and lower arm bolts “3” with lithium-soap-based grease.
- Be sure to position the front upper and lower arm bolts “3” so that the bolt heads face forward.
- Temporarily tighten the front upper and lower arm nuts “4”.

- b. Install the front shock absorber assembly “5”, bolts “6”, and nuts “7”.



Front shock absorber assembly nut
45 Nm (4.5 m·kg, 32 ft·lb)

- c. Install the steering knuckle, upper steering knuckle nut “8”, and lower steering knuckle nut “9”.



Upper steering knuckle nut
30 Nm (3.0 m·kg, 22 ft·lb)
Lower steering knuckle nut
30 Nm (3.0 m·kg, 22 ft·lb)

- d. Install the new cotter pins.
- e. Tighten the front upper and lower arm nuts “4” to specification.



Front arm nut
50 Nm (5.0 m·kg, 36 ft·lb)

FRONT ARMS AND FRONT SHOCK ABSORBER ASSEMBLIES

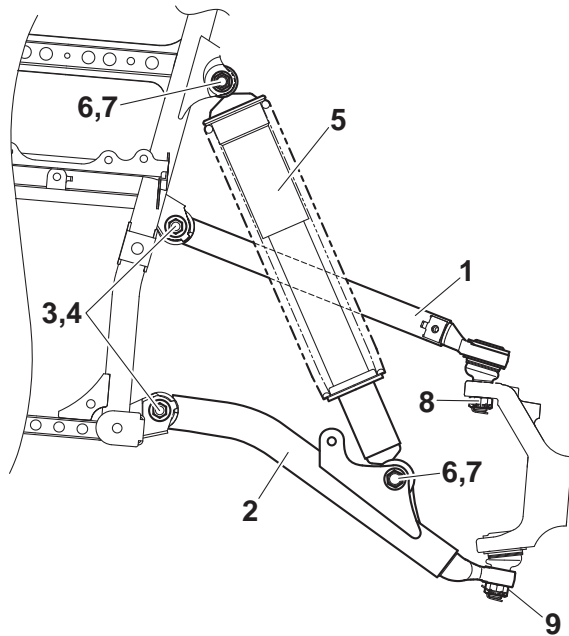

EAS28P1071

INSTALLING THE FRONT ARM PROTECTORS

The following procedure applies to both of the front arm protectors.

1. Install:

- Front arm protector "1"



**Front arm protector bolt
7 Nm (0.7 m·kg, 5.1 ft·lb)**



- Fit the holders "a" on the front arm protector onto the lower arm.
- Tighten the bolt "b".

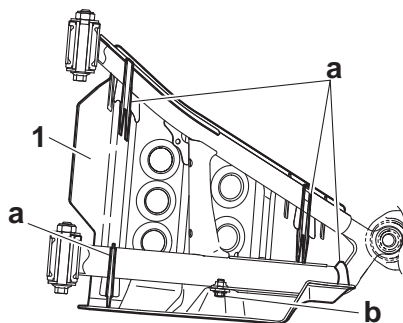

REAR KNUCKLES AND STABILIZER

EAS29800

REAR KNUCKLES AND STABILIZER

Removing the rear knuckles and stabilizer

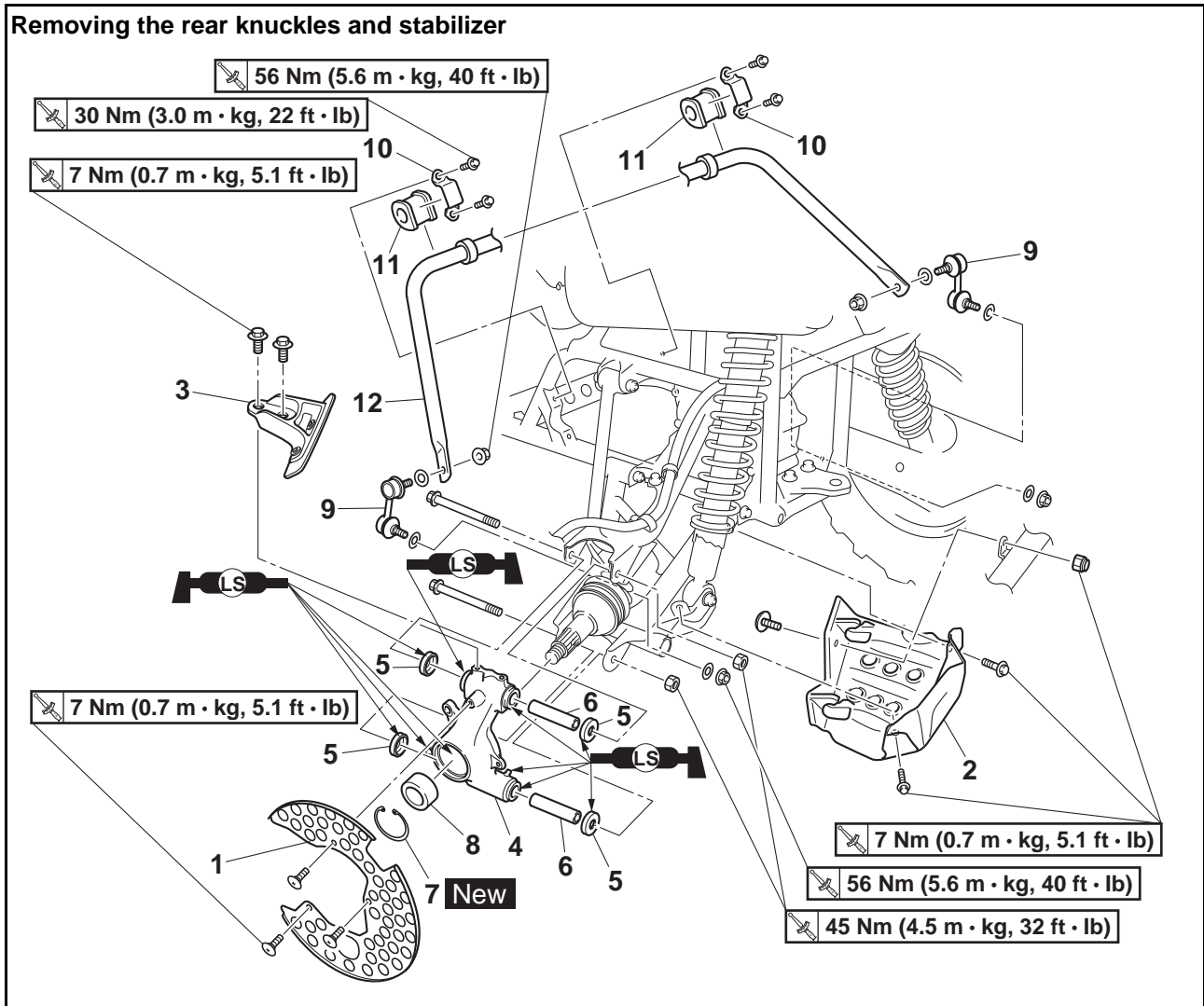

Order	Job/Parts to remove	Q'ty	Remarks
			The following procedure applies to both of the rear knuckles.
	Rear wheel hub		Refer to "REAR WHEELS" on page 4-18.
1	Brake disc guard	1	
2	Rear arm protector	1	
3	Rear brake disc cleaning plate	1	
4	Rear knuckle	1	
5	Spacer cover	4	
6	Spacer	2	
7	Circlip	1	
8	Wheel bearing	1	
9	Stabilizer joint	2	
10	Stabilizer holder	2	
11	Bushing	2	
12	Stabilizer	1	
			For installation, reverse the removal procedure.

REAR KNUCKLES AND STABILIZER

EAS29810

CHECKING THE REAR KNUCKLES AND REAR WHEEL BEARINGS

The following procedure applies to both of the rear knuckles and rear wheel bearings.

1. Check:
 - Rear knuckle
Damage/pitting → Replace.
2. Check:
 - Rear wheel bearing "1"
Rough movement/excessive free play → Replace.

-
- a. Clean the surface of the rear knuckle.
 - b. Remove the circlip "2".
 - c. Drive out the bearing.

EWA15040

WARNING

Eye protection is recommended when using striking tools.

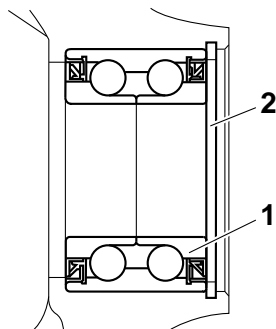

- d. Apply lithium-soap-based grease to the bearing.
- e. Install the new bearing.

ECA16190

NOTICE

Do not strike the center race or balls of the bearing. Contact should be made only with the outer race.

- f. Install the new circlip.

EAS29820

CHECKING THE STABILIZER

1. Check:
 - Stabilizer
Bends/cracks/damage → Replace.

EAS26P1005

INSTALLING THE REAR ARM PROTECTORS

The following procedure applies to both of the rear arm protectors.

1. Install:
 - Rear arm protector "1"



**Rear arm protector bolt
7 Nm (0.7 m·kg, 5.1 ft·lb)
Rear arm protector nut
7 Nm (0.7 m·kg, 5.1 ft·lb)**

-
- a. Fit the holders "a" on the rear arm protector onto the lower arm.
 - b. Tighten the bolts "b".
 - c. Tighten the nut "c".

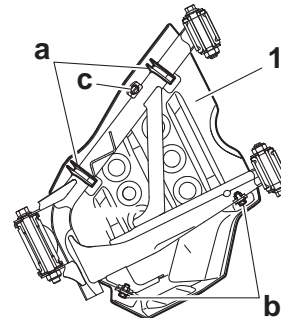

REAR ARMS AND REAR SHOCK ABSORBER ASSEMBLIES

EAS29840

REAR ARMS AND REAR SHOCK ABSORBER ASSEMBLIES

Removing the rear arms and rear shock absorber assemblies

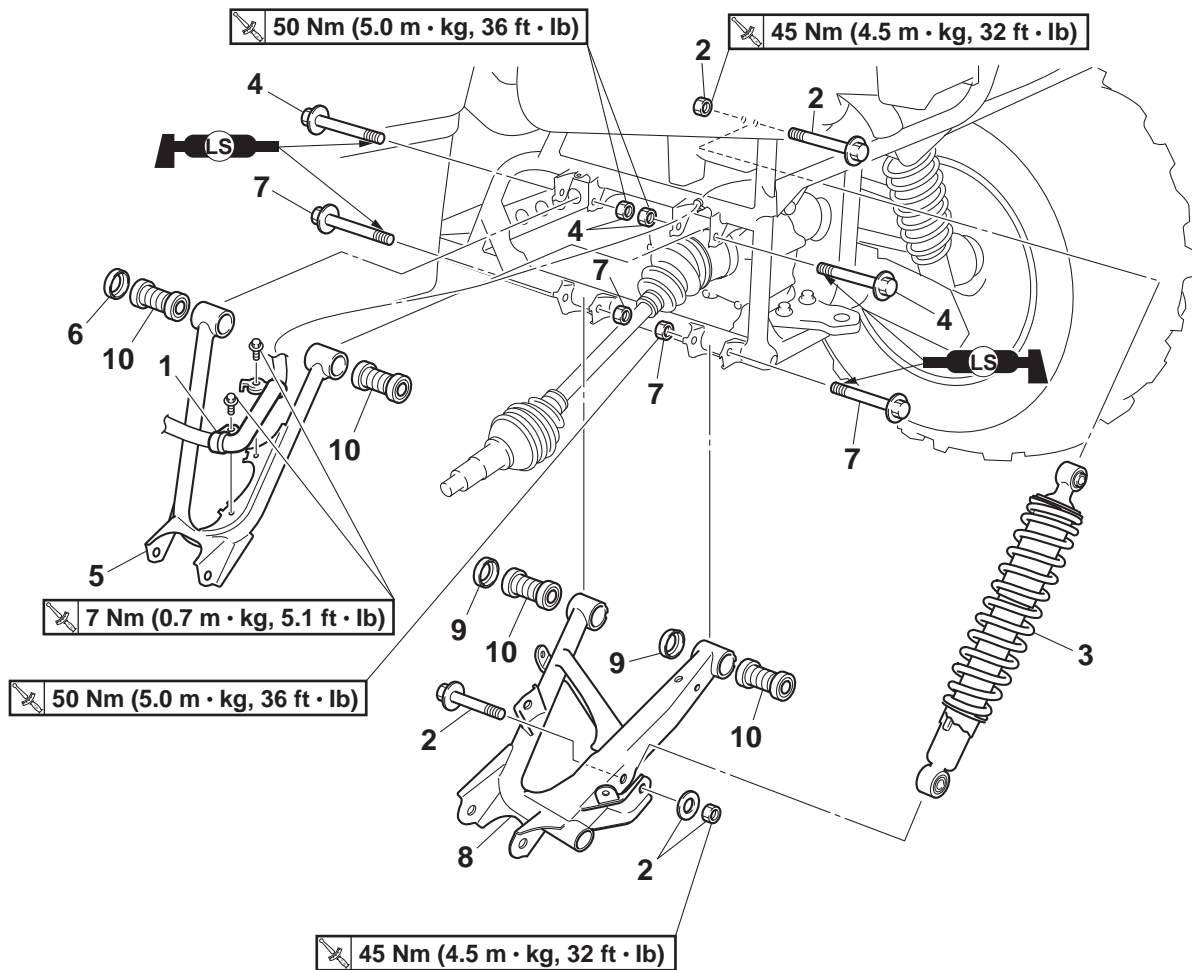

Order	Job/Parts to remove	Q'ty	Remarks
			The following procedure applies to both of the rear upper arms, rear lower arms, and rear shock absorber assemblies.
	Rear knuckle/Stabilizer		Refer to "REAR KNUCKLES AND STABILIZER" on page 4-65.
1	Rear brake hose guide	1	
2	Nut/Washer/Bolt	2/1/2	
3	Rear shock absorber assembly	1	
4	Nut/Bolt	2/2	
5	Rear upper arm	1	
6	Dust cover	1	
7	Nut/Bolt	2/2	
8	Rear lower arm	1	
9	Dust cover	2	
10	Bushing	4	
			For installation, reverse the removal procedure.

REAR ARMS AND REAR SHOCK ABSORBER ASSEMBLIES

EAS29850

CHECKING THE REAR ARMS

The following procedure applies to both of the rear upper arms and rear lower arms.

1. Check:

- Rear arm free play

a. Check the rear arm side play "A" by moving it from side to side.

If side play is noticeable, check the bushings.

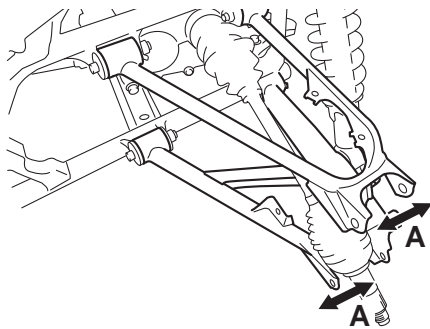

b. Check the rear arm vertical movement "B" by moving it up and down.

If the vertical movement is tight or rough, or if there is binding, check the bushings.

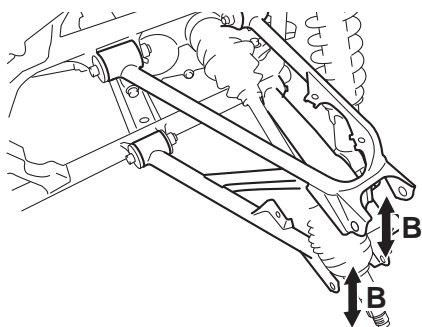

2. Check:

- Rear upper arm
- Rear lower arm
- Bends/damage → Replace.

3. Check:

- Bushings
- Wear/damage → Replace.

EAS29860

CHECKING THE REAR SHOCK ABSORBER ASSEMBLIES

The following procedure applies to both of the rear shock absorber assemblies.

1. Check:

- Rear shock absorber assembly
- Oil leaks → Replace the rear shock absorber assembly.

- Rear shock absorber rod

Bends/damage → Replace the rear shock absorber assembly.

- Spring

Move the spring up and down.

Fatigue → Replace the rear shock absorber assembly.

EAS29870

INSTALLING THE REAR ARMS AND REAR SHOCK ABSORBER ASSEMBLIES

The following procedure applies to both of the rear upper arms, rear lower arms, and rear shock absorber assemblies.

1. Install:

- Rear upper arm
- Rear lower arm
- Rear shock absorber assembly

a. Install the rear upper arm "1" and rear lower arm "2".

TIP

- Lubricate the rear upper and lower arm bolts "3" with lithium-soap-based grease.
- Be sure to position the rear upper and lower arm bolts "3" so that the bolt heads face outward.
- Temporarily tighten the rear upper and lower arm nuts "4".

b. Install the rear shock absorber assembly "5", bolts "6", and nuts "7".



Rear shock absorber assembly nut
45 Nm (4.5 m·kg, 32 ft·lb)

c. Install the rear knuckle and nuts "8".



Rear knuckle nut
45 Nm (4.5 m·kg, 32 ft·lb)

d. Tighten the rear upper and lower arm nuts "4" to specification.

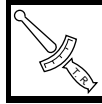

Rear arm nut
50 Nm (5.0 m·kg, 36 ft·lb)

REAR ARMS AND REAR SHOCK ABSORBER ASSEMBLIES

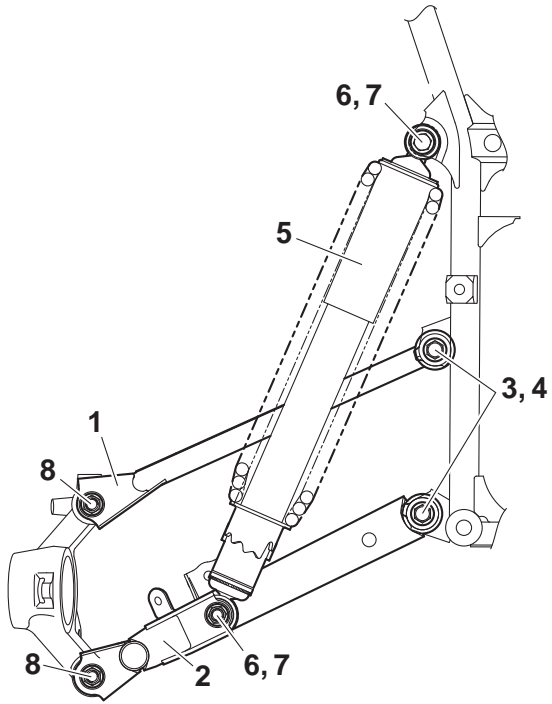

ENGINE

ENGINE REMOVAL	5-1
INSTALLING THE MUFFLER	5-2
INSTALLING THE V-BELT COOLING DUCTS	5-2
INSTALLING THE DRIVE SELECT LEVER UNIT	5-5
INSTALLING THE ENGINE	5-9
CYLINDER HEAD	5-10
REMOVING THE CYLINDER HEAD	5-12
CHECKING THE CYLINDER HEAD	5-12
CHECKING THE CAMSHAFT SPROCKET	5-13
CHECKING THE TAPPET COVERS AND CAMSHAFT SPROCKET COVER	5-13
CHECKING THE TIMING CHAIN TENSIONER	5-13
INSTALLING THE CYLINDER HEAD	5-14
ROCKER ARMS AND CAMSHAFT	5-17
REMOVING THE ROCKER ARMS AND CAMSHAFT	5-18
CHECKING THE CAMSHAFT	5-18
CHECKING THE DECOMPRESSION SYSTEM	5-19
CHECKING THE ROCKER ARMS AND ROCKER ARM SHAFTS	5-19
INSTALLING THE CAMSHAFT AND ROCKER ARMS	5-19
VALVES AND VALVE SPRINGS	5-21
REMOVING THE VALVES	5-22
CHECKING THE VALVES AND VALVE GUIDES	5-22
CHECKING THE VALVE SEATS	5-24
CHECKING THE VALVE SPRINGS	5-25
INSTALLING THE VALVES	5-26
CYLINDER AND PISTON	5-28
REMOVING THE PISTON	5-29
CHECKING THE CYLINDER AND PISTON	5-29
CHECKING THE PISTON RINGS	5-30
CHECKING THE PISTON PIN	5-31
INSTALLING THE PISTON AND CYLINDER	5-31
AC MAGNETO AND STARTER CLUTCH	5-33
REMOVING THE AC MAGNETO ROTOR	5-35
REMOVING THE STARTER CLUTCH	5-35
CHECKING THE STATOR COIL AND CRANKSHAFT POSITION SENSOR	5-36
CHECKING THE STARTER CLUTCH	5-36
CHECKING THE TORQUE LIMITER	5-36
INSTALLING THE STARTER CLUTCH	5-36
INSTALLING THE AC MAGNETO	5-37

ELECTRIC STARTER	5-39
CHECKING THE STARTER MOTOR	5-41
ASSEMBLING THE STARTER MOTOR.....	5-42
BALANCER GEARS AND OIL PUMP GEARS	5-43
REMOVING THE BALANCER DRIVEN GEAR AND OIL PUMP DRIVEN GEAR	5-44
CHECKING THE OIL PUMP DRIVE	5-44
CHECKING THE BALANCER DRIVE	5-44
INSTALLING THE BALANCER DRIVE GEAR, BALANCER DRIVEN GEAR, AND OIL PUMP DRIVEN GEAR	5-44
PRIMARY AND SECONDARY SHEAVES	5-46
REMOVING THE PRIMARY AND SECONDARY SHEAVES	5-49
DISASSEMBLING THE SECONDARY SHEAVE.....	5-49
CHECKING THE V-BELT	5-49
CHECKING THE PRIMARY SHEAVE	5-50
CHECKING THE PRIMARY SHEAVE WEIGHTS.....	5-50
CHECKING THE PRIMARY SHEAVE SLIDERS.....	5-50
CHECKING THE SECONDARY SHEAVE	5-50
ASSEMBLING THE PRIMARY SHEAVE	5-51
ASSEMBLING THE SECONDARY SHEAVE.....	5-51
INSTALLING THE PRIMARY AND SECONDARY SHEAVES.....	5-52
CLUTCH	5-54
REMOVING THE CLUTCH	5-56
CHECKING THE CLUTCH.....	5-56
CHECKING THE CLUTCH SHOE.....	5-56
ASSEMBLING THE CLUTCH HOUSING.....	5-57
INSTALLING THE CLUTCH.....	5-57
CRANKCASE	5-59
SEPARATING THE CRANKCASE	5-63
CHECKING THE TIMING CHAIN AND TIMING CHAIN GUIDE	5-63
CHECKING THE RELIEF VALVE	5-63
CHECKING THE BEARINGS.....	5-63
CHECKING THE CRANKCASE	5-64
ASSEMBLING THE CRANKCASE.....	5-64
INSTALLING THE SHIFT LEVER	5-65
CRANKSHAFT AND OIL PUMP	5-66
REMOVING THE CRANKSHAFT	5-68
CHECKING THE OIL PUMP	5-68
CHECKING THE OIL STRAINER	5-69
CHECKING THE CRANKSHAFT	5-69
ASSEMBLING THE OIL PUMP	5-69
INSTALLING THE CRANKSHAFT	5-70

TRANSMISSION	5-71
REMOVING THE TRANSMISSION	5-75
CHECKING THE SHIFT FORKS.....	5-75
CHECKING THE SHIFT DRUM	5-75
CHECKING THE TRANSMISSION	5-75
CHECKING THE SECONDARY SHAFT	5-76
CHECKING THE STOPPER LEVER AND STOPPER WHEEL.....	5-76
ASSEMBLING THE SHIFT FORK ASSEMBLY	5-76
INSTALLING THE SHIFT FORKS AND SHIFT DRUM.....	5-76
MIDDLE GEAR	5-78
REMOVING THE MIDDLE DRIVE SHAFT	5-81
REMOVING THE MIDDLE DRIVEN SHAFT	5-81
CHECKING THE PINION GEARS	5-82
INSTALLING THE BEARING AND OIL SEALS	5-83
INSTALLING THE MIDDLE DRIVEN SHAFT	5-83
INSTALLING THE MIDDLE DRIVE SHAFT	5-84
MEASURING THE MIDDLE GEAR BACKLASH.....	5-85
ALIGNING THE MIDDLE GEAR	5-86

EAS23710

ENGINE REMOVAL

Removing the V-belt cooling ducts, muffler and exhaust pipe

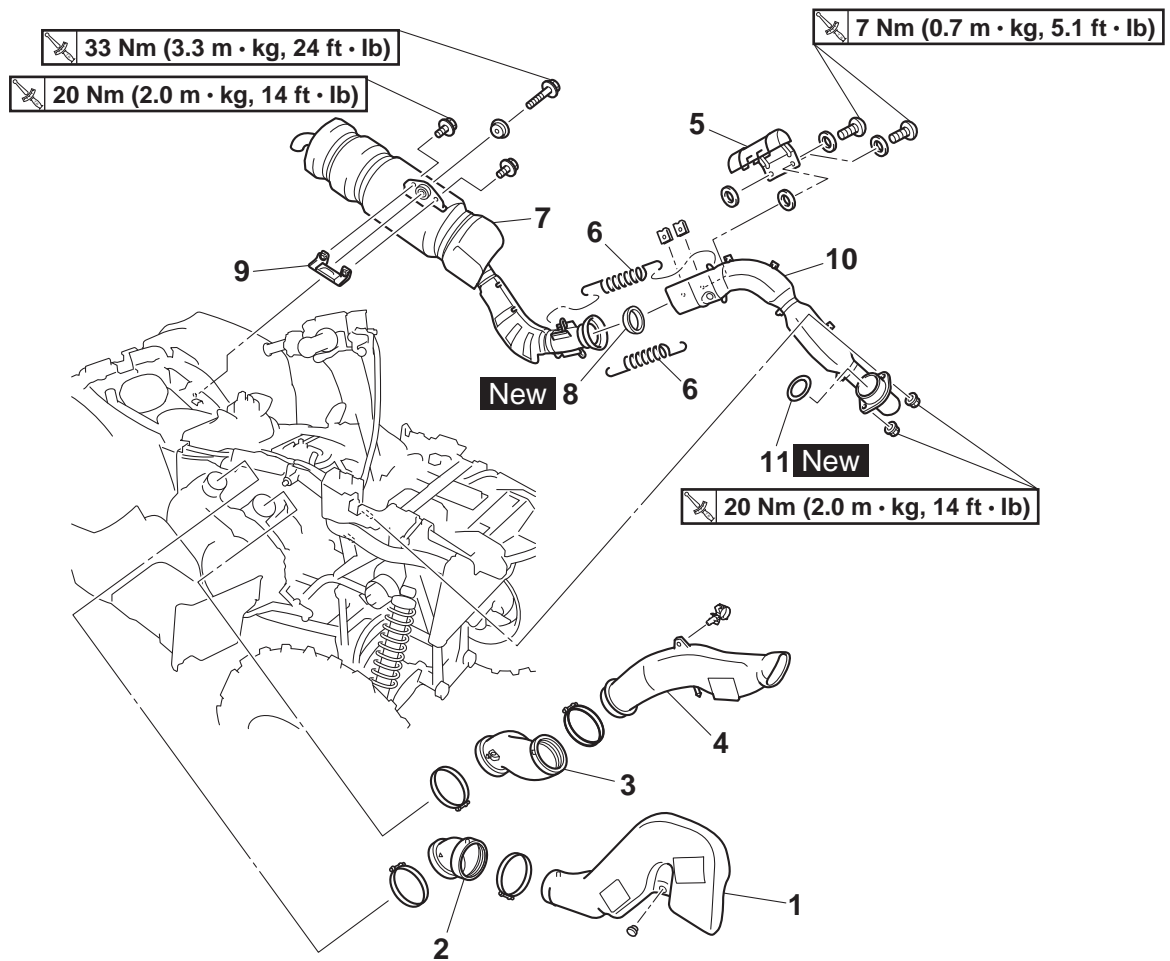

Order	Job/Parts to remove	Q'ty	Remarks
	Front fender/Rear fender/Left footrest board/Air filter case/Meter assembly		Refer to "GENERAL CHASSIS" on page 4-1.
1	V-belt cooling exhaust duct	1	
2	V-belt cooling exhaust duct joint	1	
3	V-belt cooling intake duct joint	1	
4	V-belt cooling intake duct	1	
5	Exhaust pipe protector	1	
6	Spring	2	
7	Muffler	1	
8	Gasket	1	
9	Muffler bracket	1	
10	Exhaust pipe	1	
11	Gasket	1	
			For installation, reverse the removal procedure.

ENGINE REMOVAL

EAS28P1023

INSTALLING THE MUFFLER

1. Install:

- Gasket “1” **New**
- Exhaust pipe “2”
- Exhaust pipe nuts “3”

	Exhaust pipe nut 20 Nm (2.0 m·kg, 14 ft·lb)
---	--

2. Install:

- Muffler bracket “4”
- Muffler bracket bolts “5”

	Muffler bracket bolt 20 Nm (2.0 m·kg, 14 ft·lb)
---	--

3. Install:

- Gasket “6” **New**
- Muffler “7”
- Washer “8”
- Muffler bolt “9”

TIP

Do not fully tighten the muffler bolt.

4. Install:

- Springs “10”

TIP

Install the springs so that the spring ends are pointing inward as shown in the illustration.

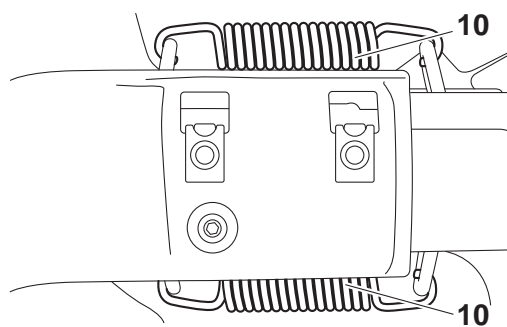

5. Tighten:

- Muffler bolt “9”

	Muffler bolt 33 Nm (3.3 m·kg, 24 ft·lb)
---	--

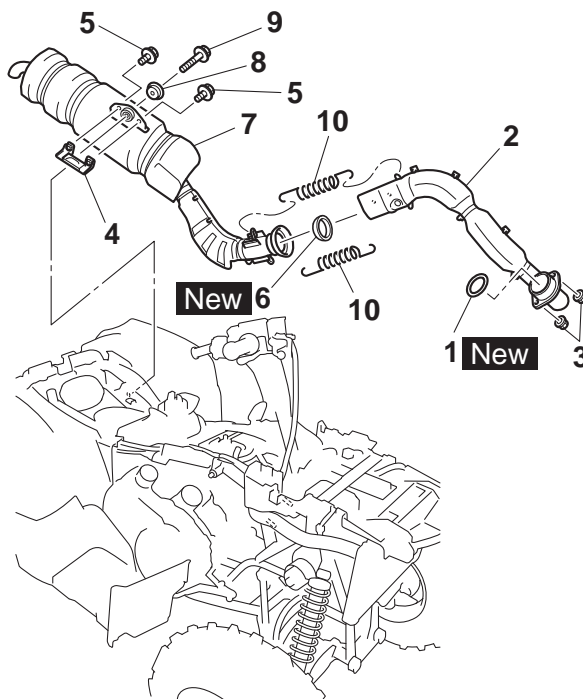

EAS28P1024

INSTALLING THE V-BELT COOLING DUCTS

1. Install:

- V-belt cooling intake duct joint “1”
- V-belt cooling intake duct “2”

- Position the V-belt cooling intake duct joint with its arrow mark “a” pointing toward the engine.
- Align the projection on the V-belt cooling intake duct joint with the rib on the crankcase in the area “b” shown in the illustration.
- Align the screw head with the seam on the V-belt cooling intake duct joint in the area “c” shown in the illustration.
- Align the projection on the V-belt cooling intake duct with the projection on the V-belt cooling intake duct joint in the area “d” shown in the illustration.
- Align the bend in the screw clamp with the projection on the V-belt cooling intake duct joint in the area “e” shown in the illustration.

ENGINE REMOVAL

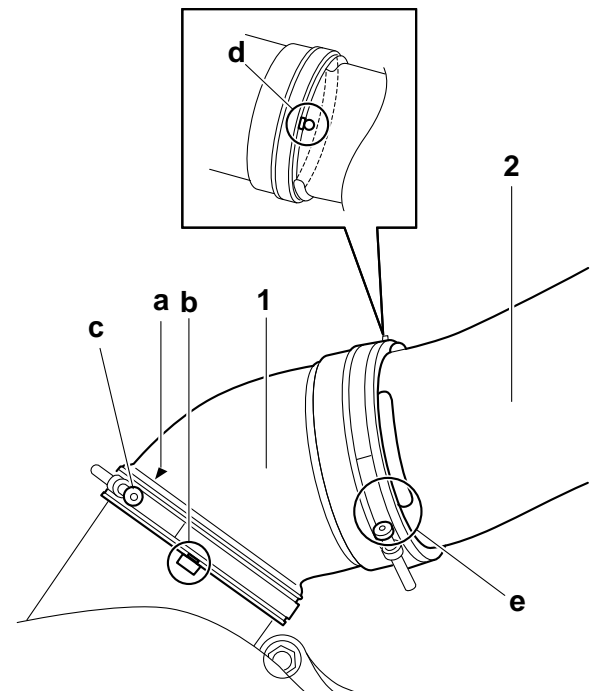
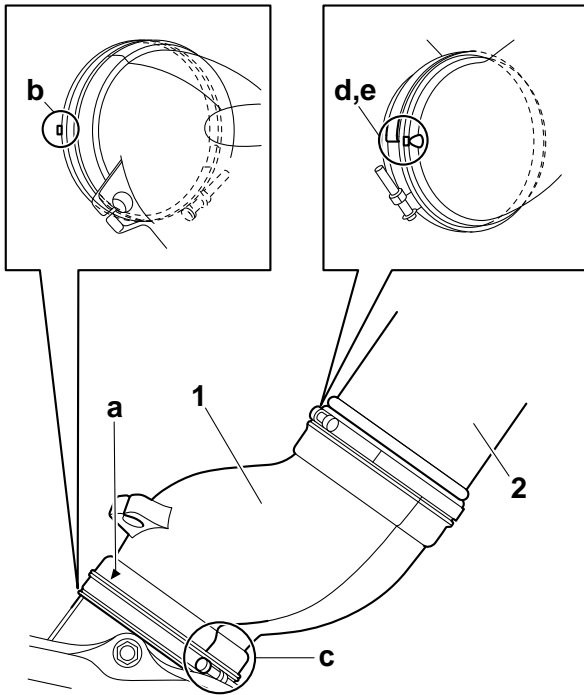

2. Install:

- V-belt cooling exhaust duct joint "1"
- V-belt cooling exhaust duct "2"

- Position the V-belt cooling exhaust duct joint with its arrow mark "a" pointing toward the engine.
- Align the projection on the V-belt cooling exhaust duct joint with the projection on the drive belt case in the area "b" shown in the illustration.
- Align the screw head with the arrow mark "a" on the V-belt cooling exhaust duct joint in the area "c" shown in the illustration.
- Align the projection on the V-belt cooling exhaust duct with the projection on the V-belt cooling exhaust duct joint in the area "d" shown in the illustration.
- Align the screw head with the rib on the V-belt cooling exhaust duct in the area "e" shown in the illustration.

ENGINE REMOVAL

Removing the drive select lever unit

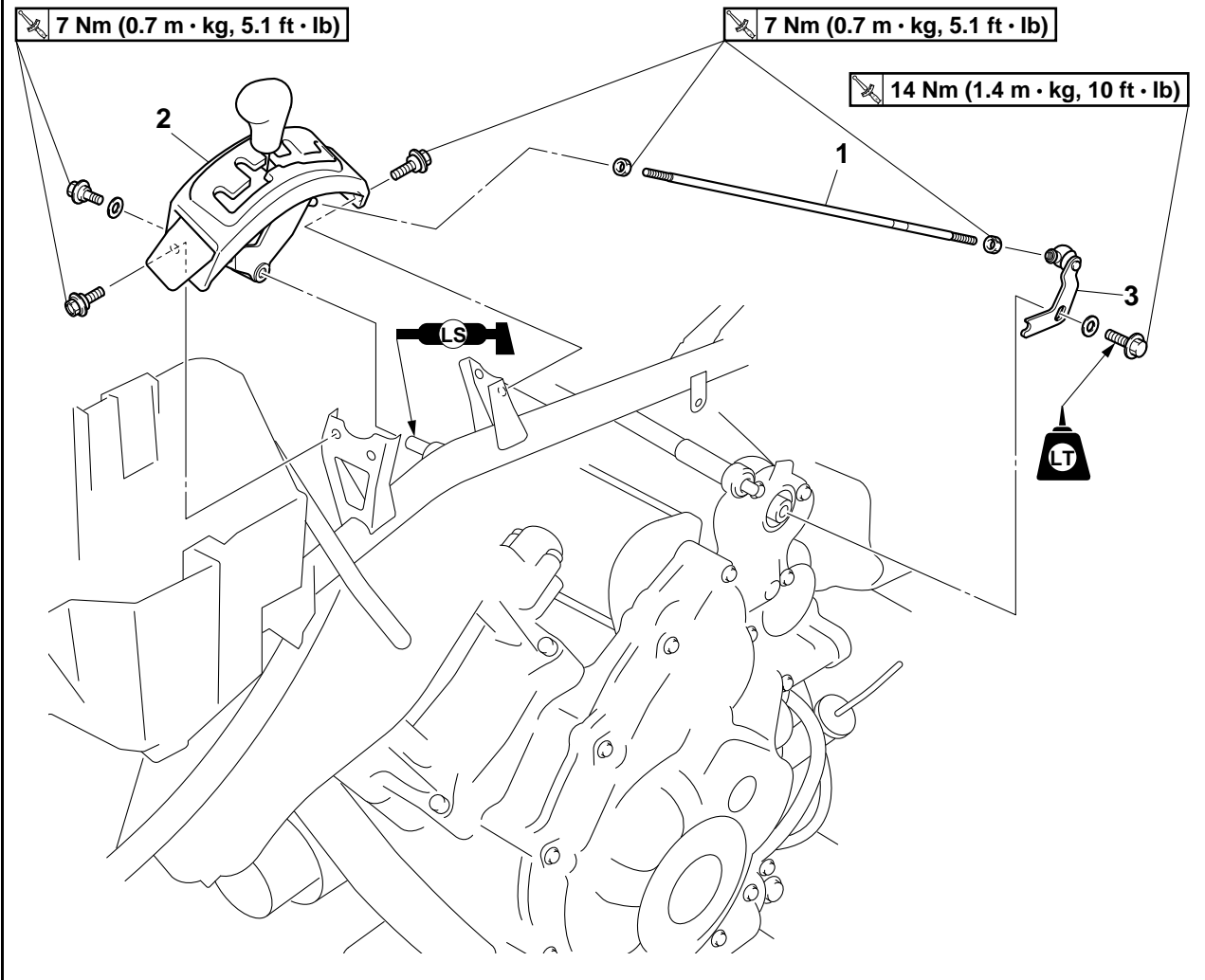

Order	Job/Parts to remove	Q'ty	Remarks
1	Drive select lever shift rod	1	
2	Drive select lever unit	1	
3	Shift arm	1	
			For installation, reverse the removal procedure.

EAS28P1025

INSTALLING THE DRIVE SELECT LEVER UNIT

1. Install:

- Shift arm "1"
- Drive select lever unit "2"
- Drive select lever shift rod "3"

	Shift arm bolt 14 Nm (1.4 m·kg, 10 ft·lb) LOCTITE®
	Drive select lever unit bolt 7 Nm (0.7 m·kg, 5.1 ft·lb)
	Drive select lever shift rod lock-nut 7 Nm (0.7 m·kg, 5.1 ft·lb)

TIP

- Make sure that the drive select lever and transmission are in "N" (neutral).
- The installed length "a" of the shift rod is 413 mm (16.3 in).

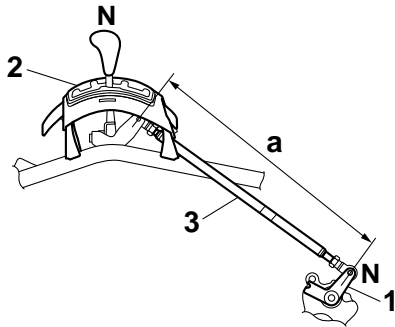

ENGINE REMOVAL

Disconnecting the leads, cables and hoses

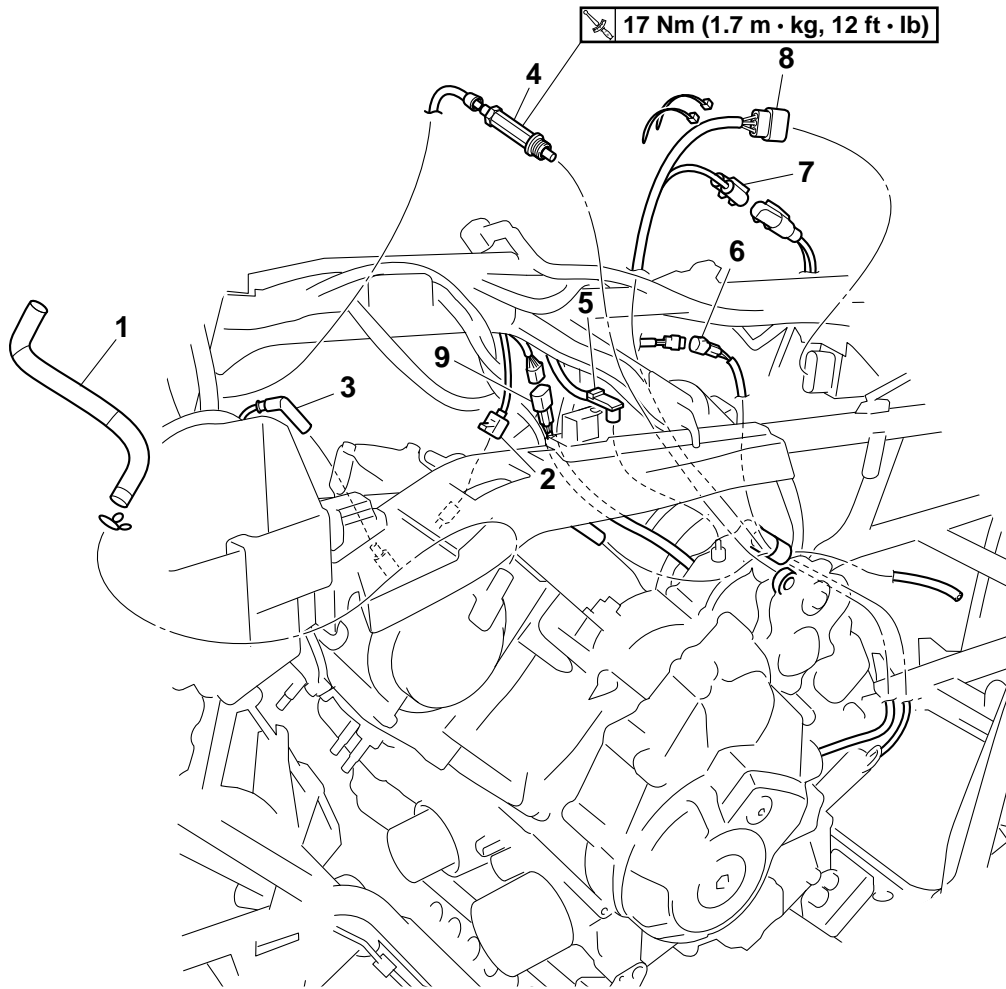

Order	Job/Parts to remove	Q'ty	Remarks
	Footrest board/Air filter case		Refer to "GENERAL CHASSIS" on page 4-1.
	Air cut-off valve assembly		Refer to "AIR INDUCTION SYSTEM" on page 7-9.
	Throttle body assembly		Refer to "THROTTLE BODY" on page 7-4.
	Fuel tank/Fuel tank shield		Refer to "FUEL TANK" on page 7-1.
	Coolant reservoir		Refer to "RADIATOR" on page 6-1.
	Thermostat		Refer to "THERMOSTAT" on page 6-4.
	Water pump assembly		Refer to "WATER PUMP" on page 6-7.
	Oil delivery pipe 2		Refer to "CYLINDER HEAD" on page 5-10.
	Oil delivery pipe 1		Refer to "AC MAGNETO AND STARTER CLUTCH" on page 5-33.
	Differential assembly		Refer to "FRONT CONSTANT VELOCITY SHAFT ASSEMBLIES, DIFFERENTIAL ASSEMBLY AND FRONT DRIVE SHAFT" on page 8-3.
	Final drive assembly		Refer to "REAR CONSTANT VELOCITY SHAFT ASSEMBLIES, FINAL DRIVE ASSEMBLY AND REAR DRIVE SHAFT" on page 8-15.

ENGINE REMOVAL

Disconnecting the leads, cables and hoses

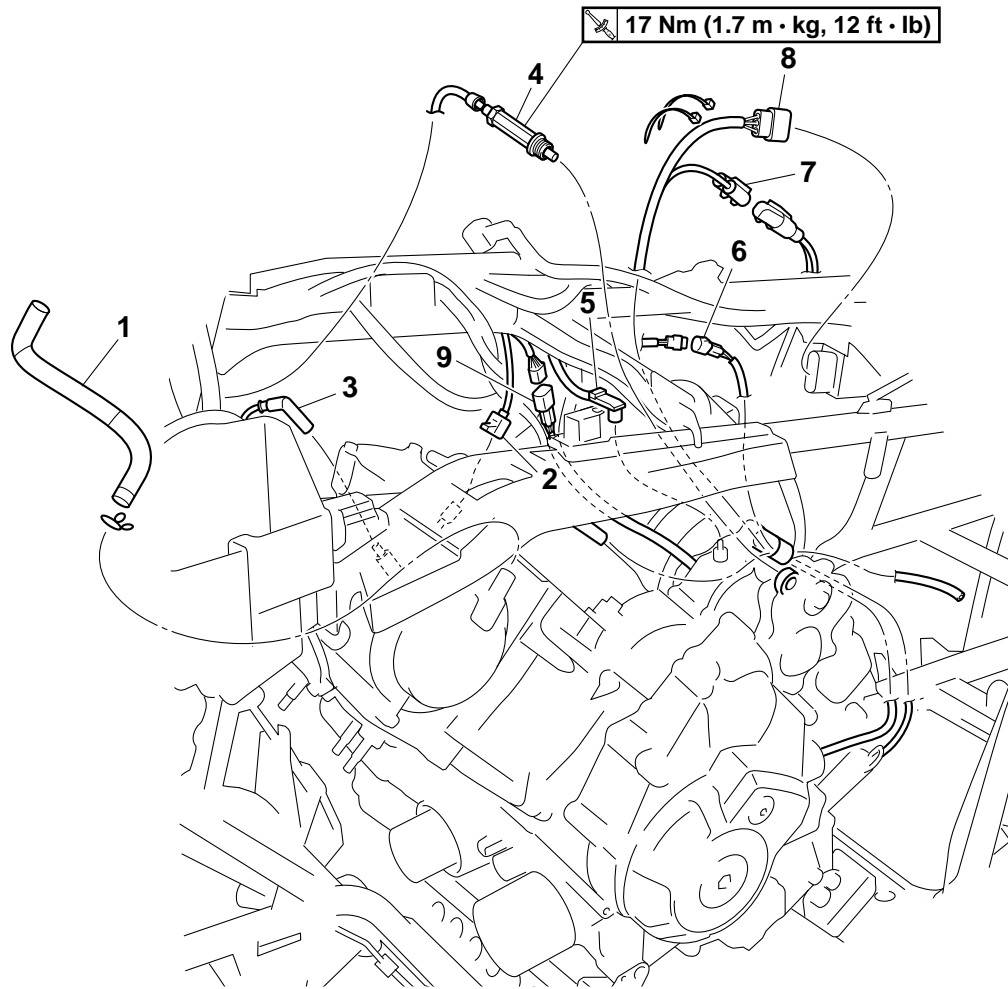

Order	Job/Parts to remove	Q'ty	Remarks
	Starter motor		Refer to "ELECTRIC STARTER" on page 5-39.
	Drive belt case		Refer to "PRIMARY AND SECONDARY SHEAVES" on page 5-46.
1	Cylinder head breather hose	1	
2	Coolant temperature sensor coupler	1	Disconnect.
3	Spark plug cap	1	
4	Shift control cable	1	Disconnect.
5	Reverse switch lead	1	Disconnect.
6	Speed sensor coupler	1	Disconnect.
7	Crankshaft position sensor coupler	1	Disconnect.
8	AC magneto coupler	1	Disconnect.
9	Gear position switch coupler	1	Disconnect.
			For installation, reverse the removal procedure.

ENGINE REMOVAL

Removing the engine

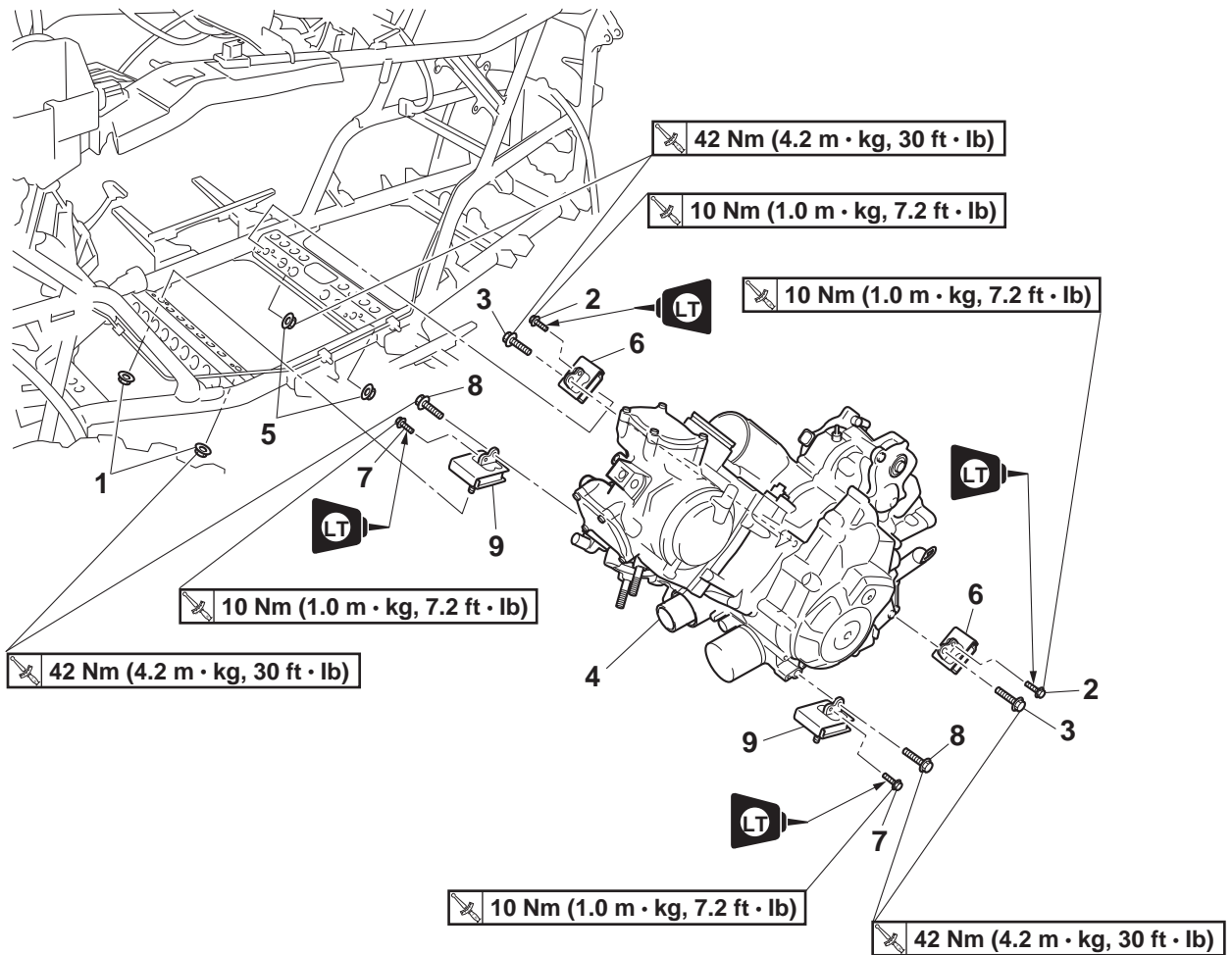

Order	Job/Parts to remove	Q'ty	Remarks
1	Rubber damper nut (front side)	2	
2	Engine mounting bolt (rear upper side)	2	
3	Engine mounting bolt (rear lower side)	2	
4	Engine	1	<p>ECA28P1024</p> <p>NOTICE _____</p> <p>Make sure that the engine does not strike the brake pipe when removing it.</p> <p>TIP _____</p> <p>Remove the engine from the left side of the vehicle.</p> <p>_____</p>
5	Rubber damper nut (rear side)	2	
6	Rubber damper (rear side)	2	
7	Engine mounting bolt (front upper side)	2	
8	Engine mounting bolt (front lower side)	2	
9	Rubber damper (front side)	2	
			For installation, reverse the removal procedure.

ENGINE REMOVAL

EAS23720

INSTALLING THE ENGINE

1. Install:

- Rubber dampers (front side) "1"
- Engine mounting bolts (front lower side) "2"
- Engine mounting bolts (front upper side) "3"
- Rubber dampers (rear side) "4"
- Rubber damper nuts (rear side) "5"
- Engine "6"
- Engine mounting bolts (rear lower side) "7"
- Engine mounting bolts (rear upper side) "8"
- Rubber damper nuts (front side) "9"

ECA28P1025

NOTICE

Make sure that the engine does not strike the brake pipe when installing it.

TIP

Do not fully tighten the bolts and nuts.



Engine mounting bolt (front lower side)

42 Nm (4.2 m·kg, 30 ft·lb)

Engine mounting bolt (front upper side)

10 Nm (1.0 m·kg, 7.2 ft·lb)

LOCTITE®

Engine mounting bolt (rear lower side)

42 Nm (4.2 m·kg, 30 ft·lb)

Engine mounting bolt (rear upper side)

10 Nm (1.0 m·kg, 7.2 ft·lb)

LOCTITE®

Rubber damper nut (front side)

42 Nm (4.2 m·kg, 30 ft·lb)

Rubber damper nut (rear side)

42 Nm (4.2 m·kg, 30 ft·lb)

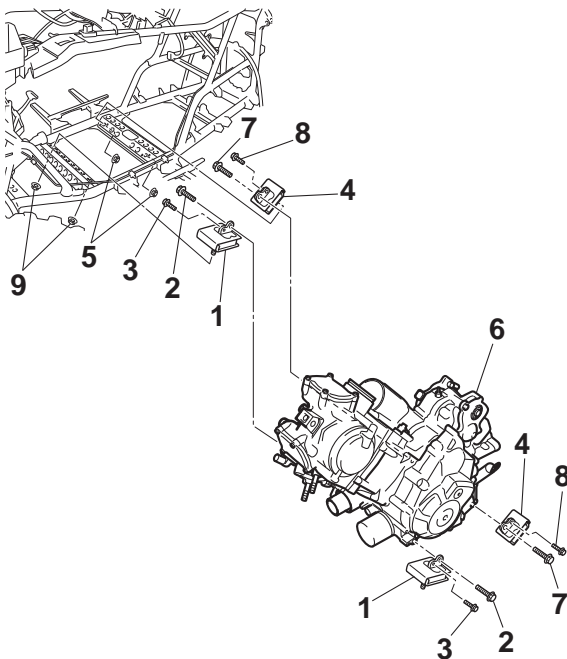

2. Tighten:

- Engine mounting bolts (front lower side) "2"
- Engine mounting bolts (front upper side) "3"
- Engine mounting bolts (rear lower side) "7"
- Engine mounting bolts (rear upper side) "8"
- Rubber damper nuts (front side) "9"
- Rubber damper nuts (rear side) "5"

EAS24100

CYLINDER HEAD

Removing the cylinder head

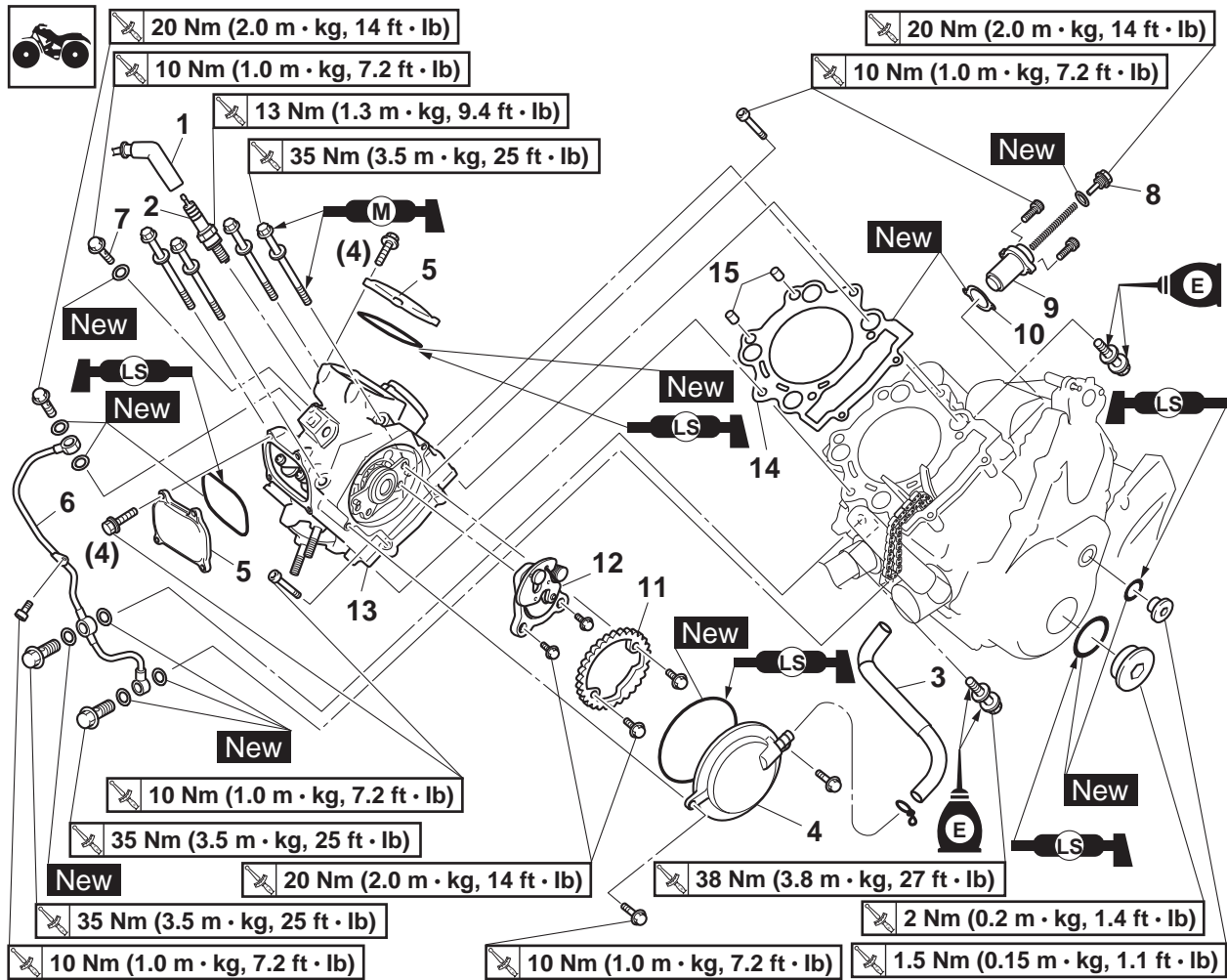

Order	Job/Parts to remove	Q'ty	Remarks
	Throttle body assembly		Refer to "THROTTLE BODY" on page 7-4.
	Thermostat/Coolant temperature sensor		Refer to "THERMOSTAT" on page 6-4.
	V-belt cooling ducts/Exhaust pipe		Refer to "ENGINE REMOVAL" on page 5-1.
	Reed valve assembly		Refer to "AIR INDUCTION SYSTEM" on page 7-9.
1	Spark plug cap	1	Disconnect.
2	Spark plug	1	
3	Cylinder head breather hose	1	
4	Camshaft sprocket cover	1	
5	Tappet cover	2	
6	Oil delivery pipe 2	1	
7	Oil check bolt	1	
8	Timing chain tensioner cap bolt	1	
9	Timing chain tensioner	1	
10	Gasket	1	
11	Camshaft sprocket	1	

CYLINDER HEAD

Removing the cylinder head

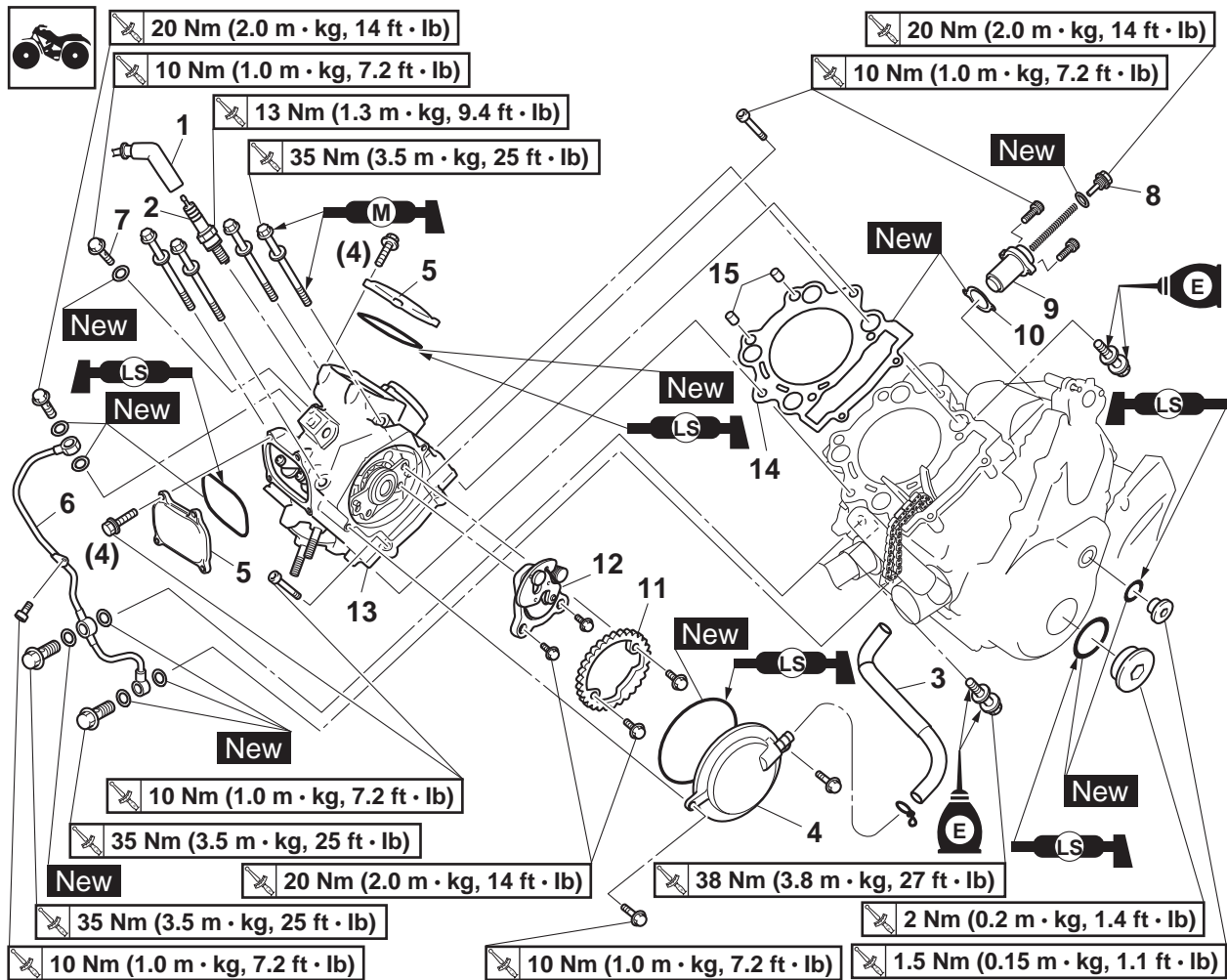

Order	Job/Parts to remove	Q'ty	Remarks
12	Decompressor assembly	1	
13	Cylinder head	1	
14	Cylinder head gasket	1	
15	Dowel pin	2	
			For installation, reverse the removal procedure.

EAS24130

REMOVING THE CYLINDER HEAD

1. Align:

- “I” mark “a” on the AC magneto rotor (with the stationary pointer “b” on the AC magneto cover)

a. Turn the crankshaft counterclockwise.

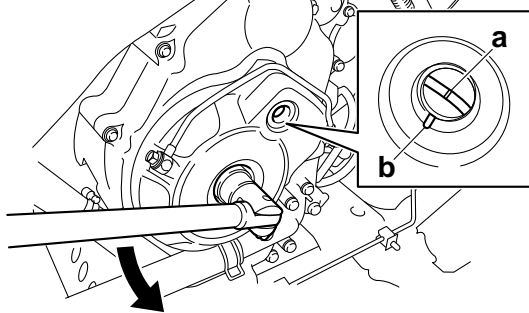

b. When the piston is at TDC on the compression stroke, align the “I” mark “c” on the camshaft sprocket with the stationary pointer “d” on the cylinder head.

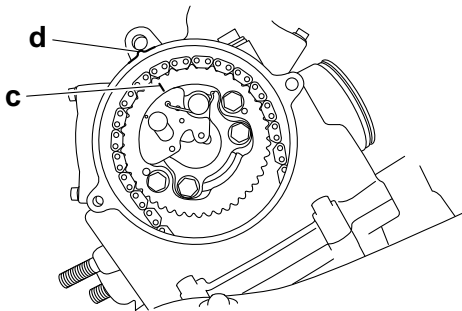

2. Loosen:

- Camshaft sprocket bolts “1”
- Decompressor assembly bolts “2”

TIP

While holding the AC magneto rotor nut with a wrench, loosen the camshaft sprocket bolts and decompressor assembly bolts.

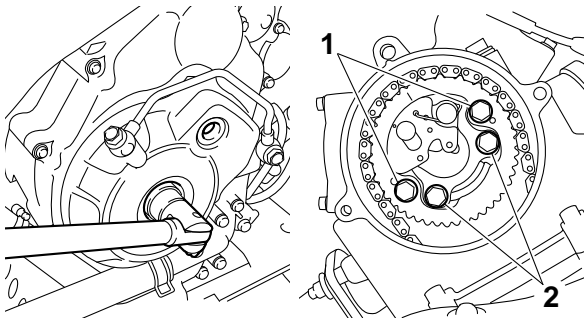

3. Loosen:

- Timing chain tensioner cap bolt

4. Remove:

- Timing chain tensioner (along with the gasket)
- Camshaft sprocket
- Timing chain

TIP

To prevent the timing chain from falling into the crankcase, fasten it with a wire.

5. Remove:

- Cylinder head

TIP

- Loosen the bolts in the proper sequence as shown.
- Loosen each bolt 1/2 of a turn at a time. After all of the bolts are fully loosened, remove them.

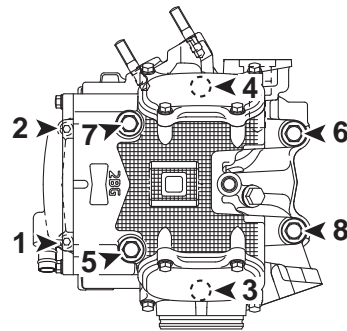

EAS24160

CHECKING THE CYLINDER HEAD

1. Eliminate:

- Combustion chamber carbon deposits (with a rounded scraper)

ECA28P1030

NOTICE

Do not use a sharp instrument; otherwise, the following may be damaged or scratched:

- Spark plug bore threads
- Valve seats

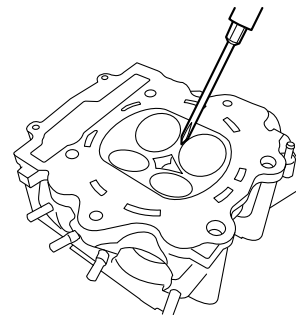

2. Check:

- Cylinder head
Damage/scratches → Replace.
- Cylinder head water jacket
Mineral deposits/rust → Eliminate.

CYLINDER HEAD

EAS24230

INSTALLING THE CYLINDER HEAD

1. Install:

- Cylinder head gasket **New**
- Dowel pins

2. Install:

- Cylinder head
- Cylinder head bolts

	Cylinder head bolt "1" 35 Nm (3.5 m·kg, 25 ft·lb)
	Cylinder head bolt "2" 35 Nm (3.5 m·kg, 25 ft·lb)
	Cylinder head bolt "3" 38 Nm (3.8 m·kg, 27 ft·lb)
	Cylinder head bolt "4" 10 Nm (1.0 m·kg, 7.2 ft·lb)

Cylinder head bolts "1"
Length: 135 mm (5.31 in)
Cylinder head bolts "2"
Length: 145 mm (5.71 in)

TIP

- Lubricate the cylinder head bolt "1" and "2" threads and mating surface with molybdenum disulfide grease.
- Lubricate the cylinder head bolts "3" threads and mating surface with engine oil.
- Tighten the cylinder head bolts in the proper tightening sequence as shown and torque them in two stages.

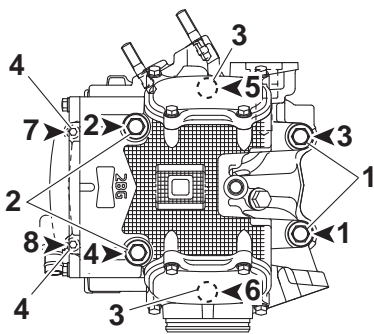

3. Install:

- Decompressor assembly
- Camshaft sprocket (onto the camshaft)

a. Install the decompressor assembly onto the camshaft, and then finger tighten the decompressor assembly bolts "1".

b. Turn the crankshaft counterclockwise.

c. Align the "I" mark "a" on the AC magneto rotor with the stationary pointer "b" on the AC magneto cover.

d. Align the "I" mark "c" on the camshaft sprocket with the stationary pointer "d" on the cylinder head.

e. Install the timing chain "2" onto the camshaft sprocket "3", and then install the camshaft sprocket onto the camshaft, and then finger tighten the camshaft sprocket bolts "4".

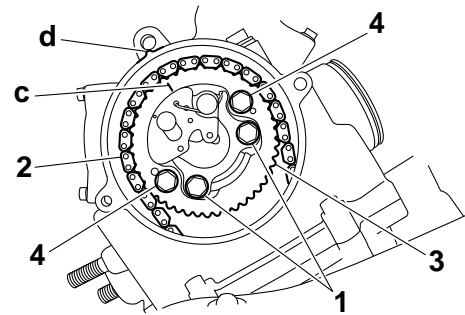
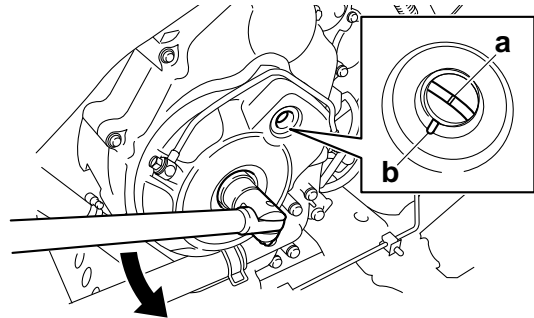

TIP

When installing the camshaft sprocket, be sure to keep the timing chain as tight as possible on the exhaust side.

ECA28P1031

NOTICE

Do not turn the crankshaft when installing the camshaft to avoid damage or improper valve timing.

f. Remove the wire from the timing chain.

4. Install:

- Timing chain tensioner

a. Remove the timing chain tensioner cap bolt "1", copper washer "2" and spring "3".

b. Release the timing chain tensioner one-way cam "4" and push the timing chain tensioner rod "5" all the way into the timing chain tensioner housing.

c. Install the timing chain tensioner and gasket "6" onto the cylinder.



Timing chain tensioner bolt
10 Nm (1.0 m·kg, 7.2 ft·lb)

CYLINDER HEAD

TIP

Install the gasket with its beaded side facing the timing chain tensioner end.

- d. Install the spring, copper washer and timing chain tensioner cap bolt.

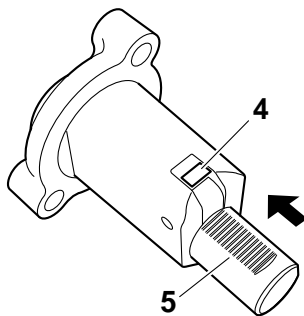
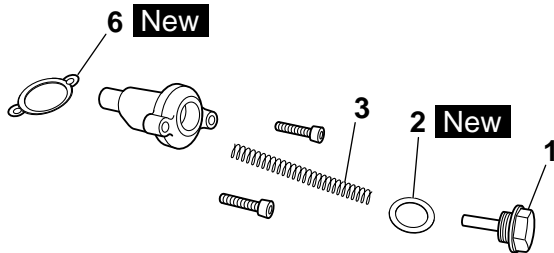
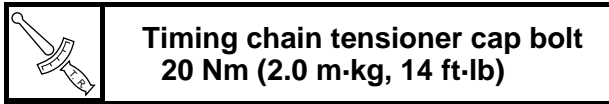

5. Turn:

- Crankshaft
(several turns counterclockwise)

6. Check:

- "I" mark "a"
Align the "I" mark on the AC magneto rotor with the stationary pointer "b" on the AC magneto cover.
- "I" mark "c"
Align the "I" mark on the camshaft sprocket with the stationary pointer "d" on the cylinder head.

Out of alignment → Correct.

Refer to the installation steps above.

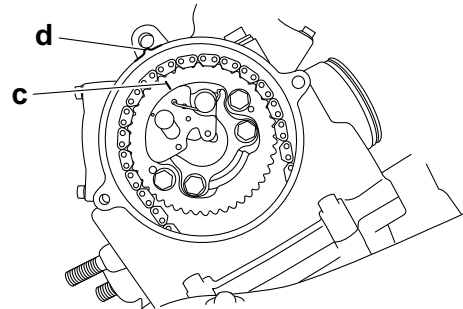
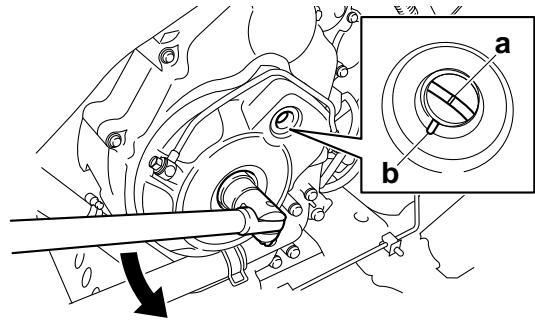

7. Tighten:

- Camshaft sprocket bolts "1"
- Decompressor assembly bolts "2"

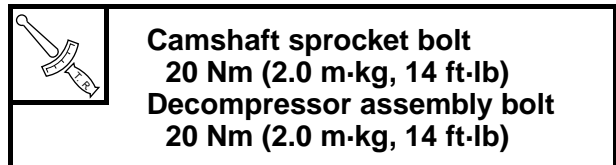

ECA13750

NOTICE

Be sure to tighten the camshaft sprocket bolts to the specified torque to avoid the possibility of the bolts coming loose and damaging the engine.

TIP

- While holding the AC magneto rotor nut with a wrench, tighten the camshaft sprocket bolts and decompressor assembly bolts.
- After tightening the decompressor assembly bolts, check that decompressor assembly moves smoothly.

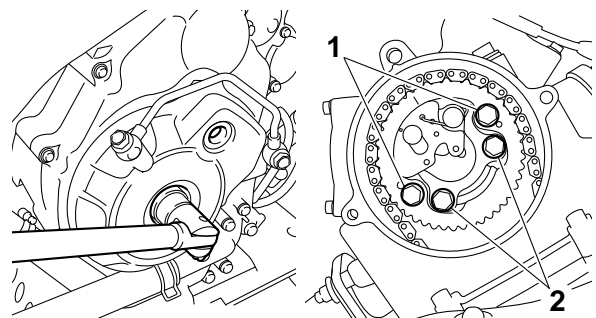

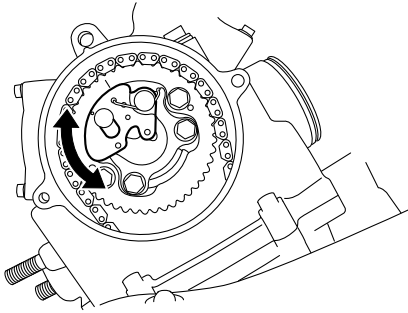

8. Measure:

- Valve clearance
Out of specification → Adjust.
Refer to “ADJUSTING THE VALVE CLEAR-
ANCE” on page 3-4.

ROCKER ARMS AND CAMSHAFT

EAS28P1027

ROCKER ARMS AND CAMSHAFT

Removing the rocker arms and camshaft

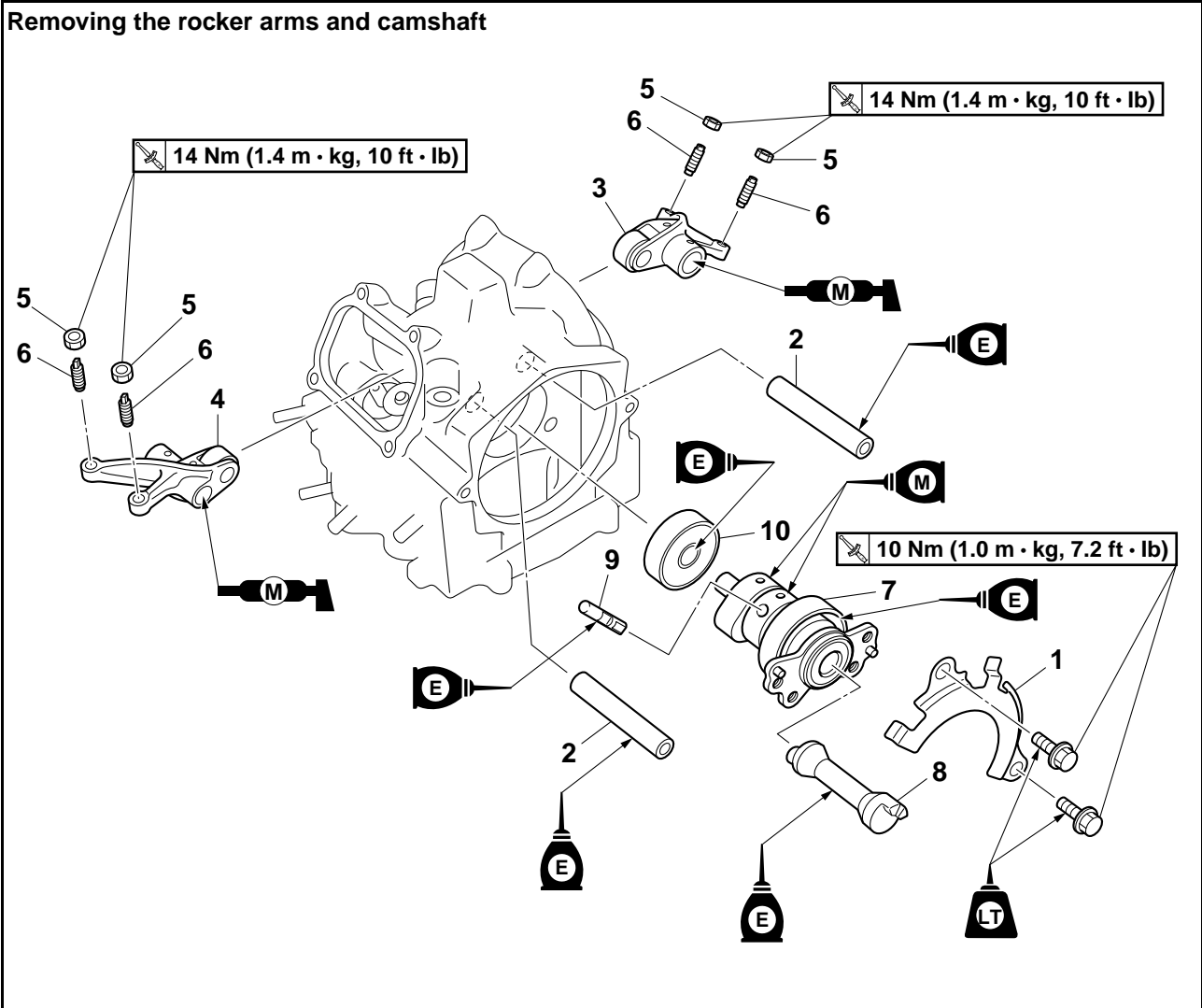

Order	Job/Parts to remove	Q'ty	Remarks
	Cylinder head		Refer to "CYLINDER HEAD" on page 5-10.
1	Bearing retainer	1	
2	Rocker arm shaft	2	
3	Intake rocker arm	1	
4	Exhaust rocker arm	1	
5	Locknut	4	
6	Valve adjusting screw	4	
7	Camshaft	1	ECA28P1026 NOTICE Do not disassemble the camshaft assembly.
8	Decompressor lever	1	
9	Decompressor lever pin	1	
10	Bearing	1	
			For installation, reverse the removal procedure.

ROCKER ARMS AND CAMSHAFT

EAS23770

REMOVING THE ROCKER ARMS AND CAMSHAFT

1. Loosen:
 - Locknuts
 - Valve clearance adjusting screws
2. Remove:
 - Intake rocker arm shaft
 - Exhaust rocker arm shaft
 - Intake rocker arm
 - Exhaust rocker arm

TIP

Remove the rocker arm shafts with the slide hammer bolt "1" and weight "2".



Slide hammer bolt
90890-01083
Slide hammer bolt 6 mm
YU-01083-1
Weight
90890-01084
YU-01083-3

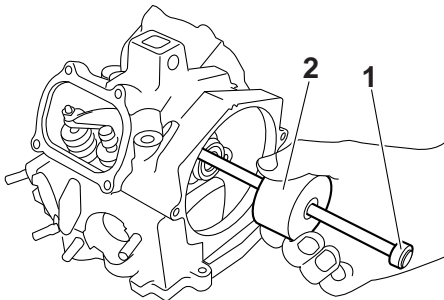

EAS23840

CHECKING THE CAMSHAFT

1. Check:
 - Camshaft lobes
Blue discoloration/pitting/scratches → Replace the camshaft.
2. Measure:
 - Camshaft lobe dimensions "a" and "b"
Out of specification → Replace the camshaft.



Camshaft lobe dimensions

Intake A

42.985–43.085 mm (1.6923–1.6963 in)

Limit

42.885 mm (1.6884 in)

Intake B

36.950–37.050 mm (1.4547–1.4587 in)

Limit

36.850 mm (1.4508 in)

Exhaust A

43.490–43.590 mm (1.7122–1.7161 in)

Limit

43.390 mm (1.7083 in)

Exhaust B

36.950–37.050 mm (1.4547–1.4587 in)

Limit

36.850 mm (1.4508 in)

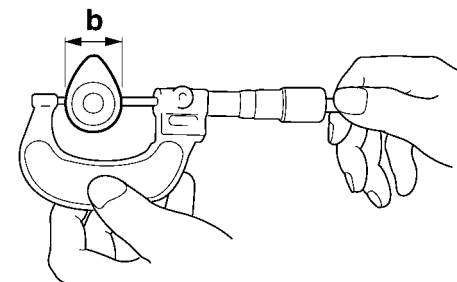
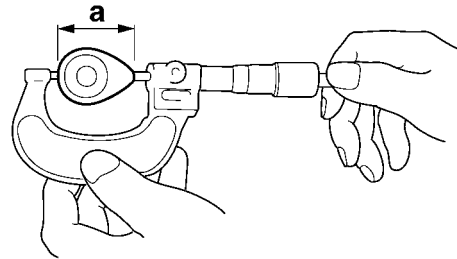

3. Measure:

- Camshaft runout
Out of specification → Replace the camshaft.



Camshaft runout limit
0.015 mm (0.0006 in)

ROCKER ARMS AND CAMSHAFT

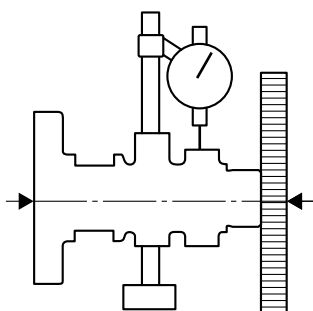

EAS28P1028

CHECKING THE DECOMPRESSION SYSTEM

1. Check:

- Decompression system



- Check the decompression system with the camshaft sprocket installed on the decompressor lever and pin installed in the camshaft.
- Check that the decompressor lever pin "1" projects from the camshaft.
- Check that the decompressor cam "2" moves smoothly.

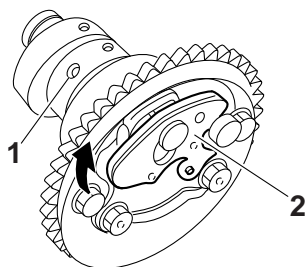

EAS23880

CHECKING THE ROCKER ARMS AND ROCKER ARM SHAFTS

The following procedure applies to all of the rocker arms and rocker arm shafts.

1. Check:

- Rocker arm
Damage/wear → Replace.

2. Check:

- Rocker arm shaft
Blue discoloration/excessive wear/pitting/scratches → Replace or check the lubrication system.

3. Measure:

- Rocker arm inside diameter
Out of specification → Replace.



Rocker arm inside diameter
12.000–12.018 mm (0.4724–0.4731 in)

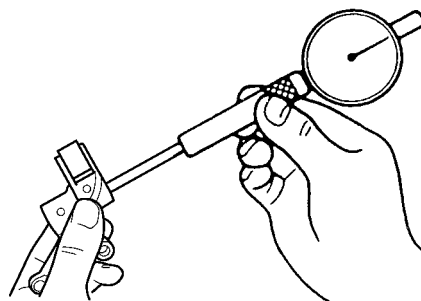

4. Measure:

- Rocker arm shaft outside diameter
Out of specification → Replace.



Rocker arm shaft outside diameter
11.981–11.991 mm (0.4717–0.4721 in)

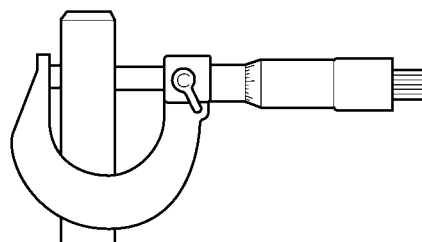

5. Calculate:

- Rocker-arm-to-rocker-arm-shaft clearance
Out of specification → Replace the defective part(s).



Rocker-arm-to-rocker-arm-shaft clearance
0.009–0.037 mm (0.0004–0.0015 in)

TIP

Calculate the clearance by subtracting the rocker arm shaft outside diameter from the rocker arm inside diameter.

EAS24040

INSTALLING THE CAMSHAFT AND ROCKER ARMS

1. Install:

- Bearing "1"
(onto the cylinder head)

ROCKER ARMS AND CAMSHAFT

TIP

- Apply engine oil to the bearing.
- Install the bearing so that the seal "a" is facing the camshaft.



**Installed depth
0 mm (0 in)**

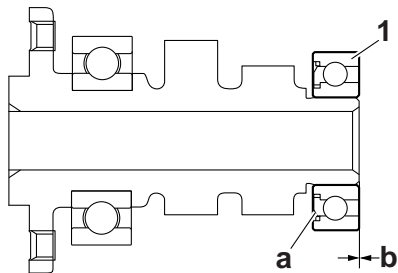

b. Installed depth

2. Lubricate:

- Camshaft
- Decompressor lever pin
- Decompressor lever

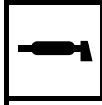

Recommended lubricant
Camshaft
Molybdenum disulfide oil
Camshaft bearing, decompressor
lever pin, decompressor lever
Engine oil

3. Install:

- Decompressor lever pin "1"
- Decompressor lever "2"

TIP

Install the decompressor lever pin "1" and decompressor lever "2" in the camshaft "3" as shown in the illustration.

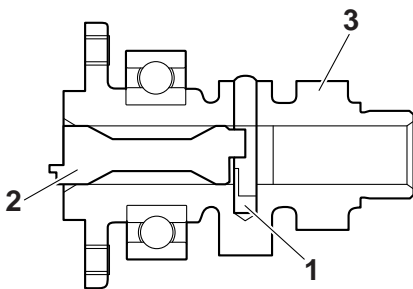

4. Install:

- Camshaft "1"

TIP

Install the camshaft so that the pins "a" become horizontal.

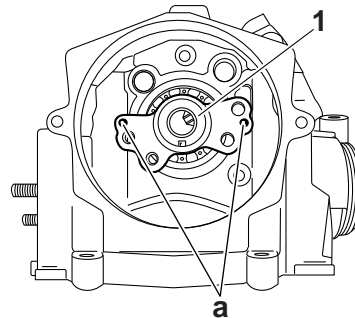

5. Lubricate:

- Rocker arms
- Rocker arm shafts



Recommended lubricant
Rocker arm inner surface
Molybdenum disulfide grease
Rocker arm shaft
Engine oil

6. Install:

- Exhaust rocker arm "1"
- Exhaust rocker arm shaft "2"
- Intake rocker arm
- Intake rocker arm shaft

TIP

- Use a slide hammer bolt "3" to install the rocker arm shaft.
- Make sure the rocker arm shafts are completely pushed into the cylinder head.



Slide hammer bolt
90890-01083
Slide hammer bolt 6 mm
YU-01083-1

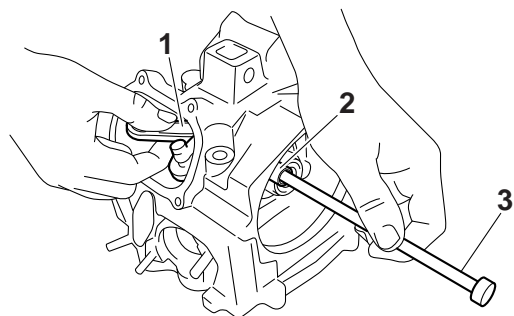

VALVES AND VALVE SPRINGS

EAS24270

VALVES AND VALVE SPRINGS

Removing the valves and valve springs

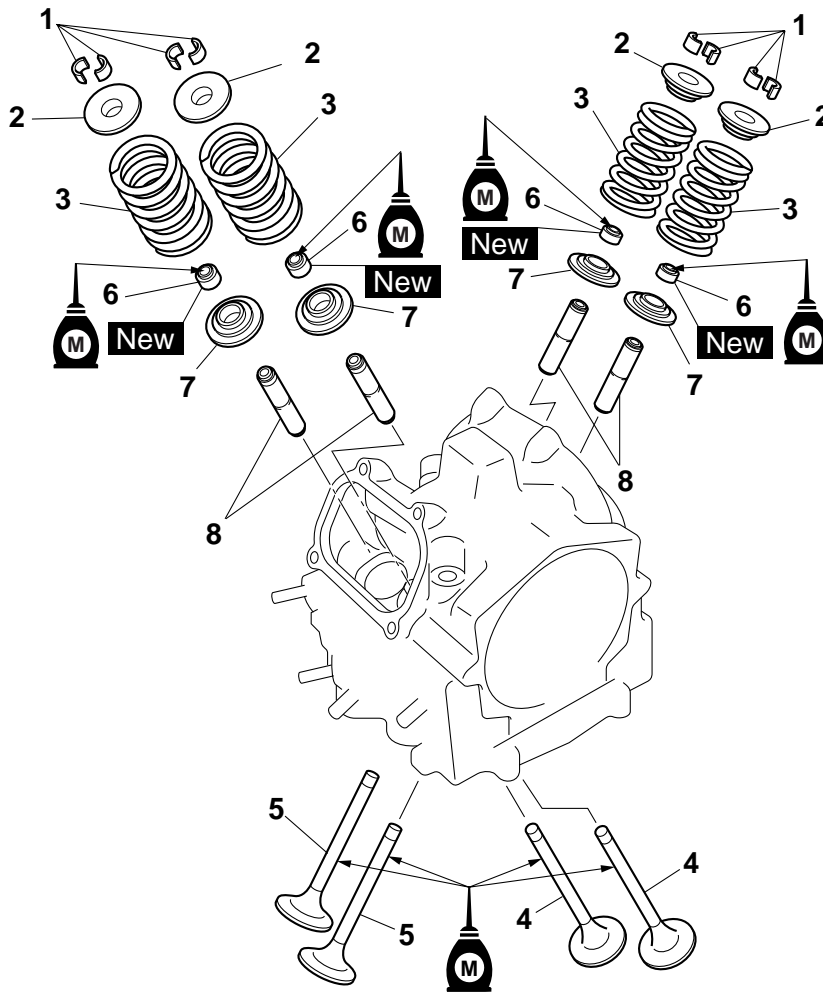

Order	Job/Parts to remove	Q'ty	Remarks
	Cylinder head		Refer to "CYLINDER HEAD" on page 5-10.
	Rocker arms/Rocker arm shafts/Camshaft		Refer to "ROCKER ARMS AND CAM-SHAFT" on page 5-17.
1	Valve cotter	8	
2	Valve spring retainer	4	
3	Valve spring	4	
4	Exhaust valve	2	
5	Intake valve	2	
6	Valve stem seal	4	
7	Valve spring seat	4	
8	Valve guide	4	
			For installation, reverse the removal procedure.

VALVES AND VALVE SPRINGS

EAS24280

REMOVING THE VALVES

The following procedure applies to all of the valves and related components.

TIP

Before removing the internal parts of the cylinder head (e.g., valves, valve springs, valve seats), make sure the valves properly seal.

1. Check:

- Valve sealing
Leakage at the valve seat → Check the valve face, valve seat, and valve seat width.
Refer to "CHECKING THE VALVE SEATS" on page 5-24.

- Pour a clean solvent "a" into the intake and exhaust ports.
- Check that the valves properly seal.

TIP

There should be no leakage at the valve seat "1".

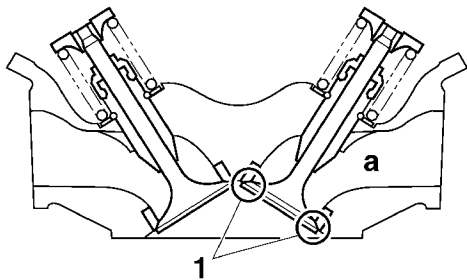

2. Remove:

- Valve cotters

TIP

Remove the valve cotters by compressing the valve spring with the valve spring compressor "1" and the valve spring compressor attachment "2".



Valve spring compressor
90890-04019
YM-04019
Valve spring compressor attachment
90890-01243
Valve spring compressor adapter (26 mm)
YM-01253-1

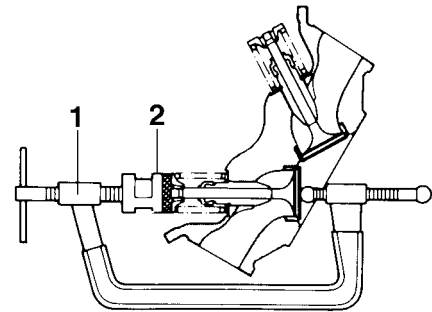

3. Remove:

- Valve spring retainer "1"
- Valve spring "2"
- Valve "3"
- Valve stem seal "4"
- Valve spring seat "5"

TIP

Identify the position of each part very carefully so that it can be reinstalled in its original place.

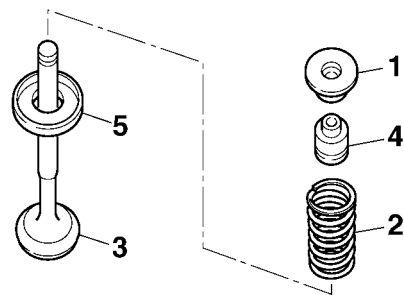

EAS24290

CHECKING THE VALVES AND VALVE GUIDES

The following procedure applies to all of the valves and valve guides.

1. Measure:

- Valve-stem-to-valve-guide clearance
Out of specification → Replace the valve guide.

• Valve-stem-to-valve-guide clearance =
Valve guide inside diameter "a" -
Valve stem diameter "b"

VALVES AND VALVE SPRINGS



Valve-stem-to-valve-guide clearance (intake)
 0.010–0.037 mm (0.0004–0.0015 in)
Limit
 0.080 mm (0.0031 in)
Valve-stem-to-valve-guide clearance (exhaust)
 0.025–0.052 mm (0.0010–0.0020 in)
Limit
 0.100 mm (0.0039 in)

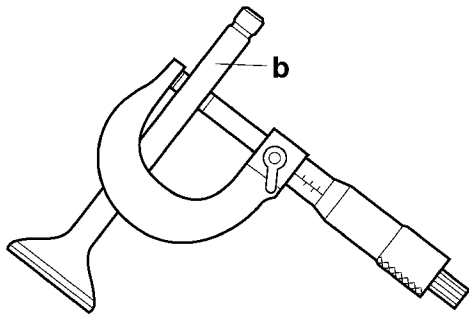
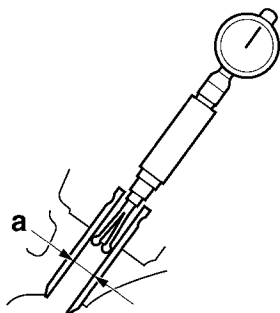

2. Replace:
- Valve guide

TIP

To ease valve guide removal and installation, and to maintain the correct fit, heat the cylinder head to 100 °C (212 °F) in an oven.

- a. Remove the valve guide with the valve guide remover "1".

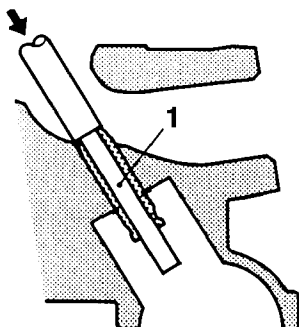

- b. Install the new valve guide with the valve guide installer "2" and valve guide remover "1".



Valve guide position
 12.7–13.1 mm (0.50–0.52 in)

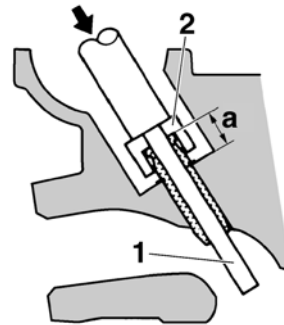

- a. Valve guide position

- c. After installing the valve guide, bore the valve guide with the valve guide reamer "3" to obtain the proper valve-stem-to-valve-guide clearance.

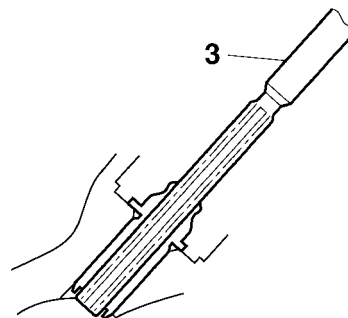

TIP

After replacing the valve guide, reface the valve seat.



Valve guide remover (ø6)
 90890-04064
Valve guide remover (6.0 mm)
 YM-04064-A
Valve guide installer (ø6)
 90890-04065
Valve guide installer (6.0 mm)
 YM-04065-A
Valve guide reamer (ø6)
 90890-04066
Valve guide reamer (6.0 mm)
 YM-04066

3. Eliminate:

- Carbon deposits
 (from the valve face and valve seat)



VALVES AND VALVE SPRINGS

4. Check:

- Valve face
Pitting/wear → Grind the valve face.
- Valve stem end
Mushroom shape or diameter larger than the body of the valve stem → Replace the valve.

5. Measure:

- Valve margin thickness "a"
Out of specification → Replace the valve.

	Valve margin thickness D (intake) 0.80–1.20 mm (0.0315–0.0472 in)
	Limit 0.4 mm (0.02 in)
	Valve margin thickness D (exhaust) 0.80–1.20 mm (0.0315–0.0472 in)
	Limit 0.4 mm (0.02 in)

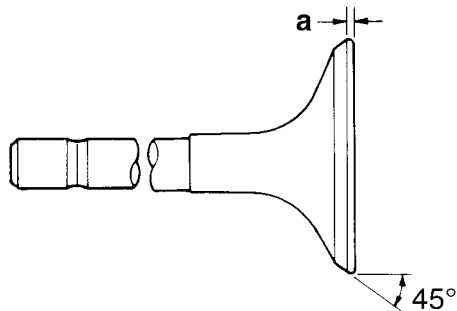

6. Measure:

- Valve stem runout
Out of specification → Replace the valve.

TIP

- When installing a new valve, always replace the valve guide.
- If the valve is removed or replaced, always replace the valve stem seal.

	Width A 74.92–75.00 mm (2.950–2.953 in)
---	---

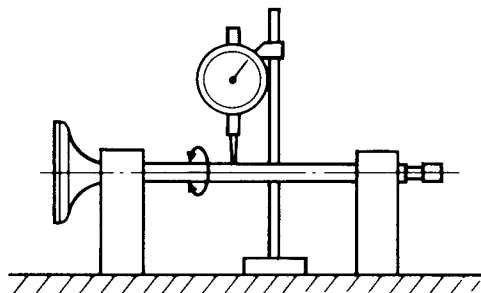

EAS24300

CHECKING THE VALVE SEATS

The following procedure applies to all of the valves and valve seats.

1. Eliminate:



- Carbon deposits
(from the valve face and valve seat)

2. Check:

- Valve seat
Pitting/wear → Replace the cylinder head.

3. Measure:

- Valve seat width C "a"
Out of specification → Replace the cylinder head.

	Valve seat width C (intake) 1.00–1.20 mm (0.0394–0.0472 in)
	Limit 1.60 mm (0.0630 in)
	Valve seat width C (exhaust) 1.00–1.20 mm (0.0394–0.0472 in)
	Limit 1.60 mm (0.0630 in)

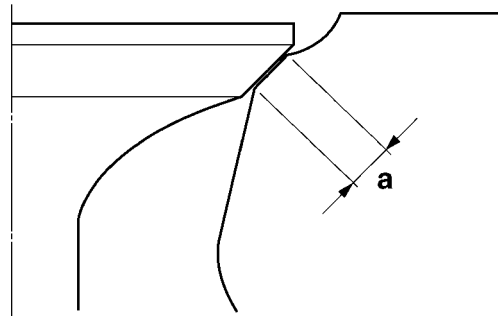

a. Apply blue layout fluid "b" onto the valve face.

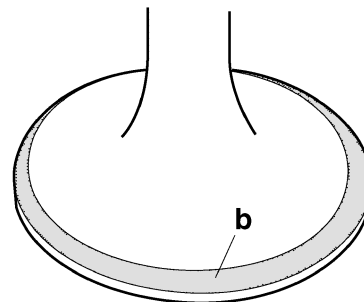

b. Install the valve into the cylinder head.

c. Press the valve through the valve guide and onto the valve seat to make a clear impression.

d. Measure the valve seat width.

TIP

Where the valve seat and valve face contacted one another, the blue layout fluid will have been removed.



4. Lap:

- Valve face
- Valve seat

TIP

After replacing the cylinder head or replacing the valve and valve guide, the valve seat and valve face should be lapped.



- a. Apply a coarse lapping compound "a" to the valve face.

ECA13790

NOTICE

Do not let the lapping compound enter the gap between the valve stem and the valve guide.

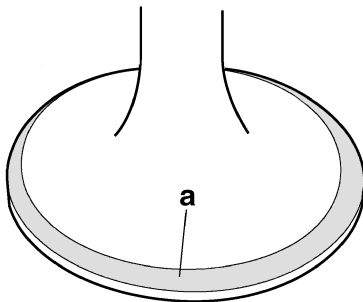

- b. Apply molybdenum disulfide oil onto the valve stem.

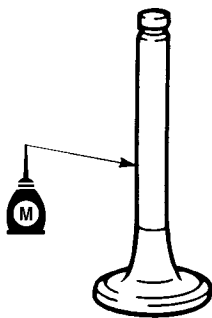

- c. Install the valve into the cylinder head.
 d. Turn the valve until the valve face and valve seat are evenly polished, then clean off all of the lapping compound.

TIP

For the best lapping results, lightly tap the valve seat while rotating the valve back and forth between your hands.

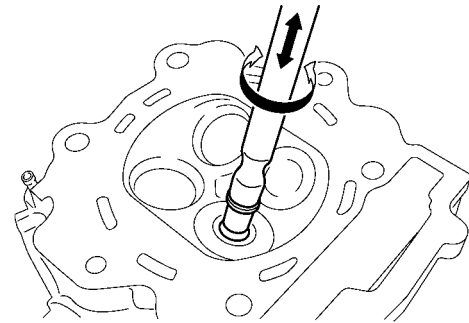

- e. Apply a fine lapping compound to the valve face and repeat the above steps.
 f. After every lapping procedure, be sure to clean off all of the lapping compound from the valve face and valve seat.
 g. Apply blue layout fluid "b" onto the valve face.

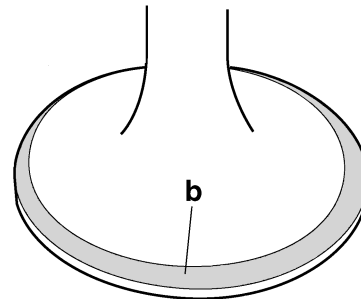

- h. Install the valve into the cylinder head.
 i. Press the valve through the valve guide and onto the valve seat to make a clear impression.
 j. Measure the valve seat width "c" again. If the valve seat width is out of specification, reface and lap the valve seat.

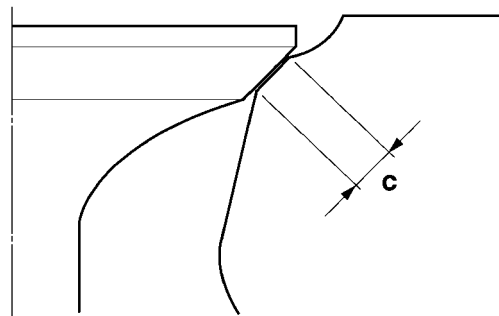

EAS24310

CHECKING THE VALVE SPRINGS

The following procedure applies to all of the valve springs.

1. Measure:
- Valve spring free length "a"
- Out of specification → Replace the valve spring.

VALVES AND VALVE SPRINGS

 **Free length (intake)**
40.38 mm (1.59 in)
Limit
38.36 mm (1.51 in)
Free length (exhaust)
40.38 mm (1.59 in)
Limit
38.36 mm (1.51 in)

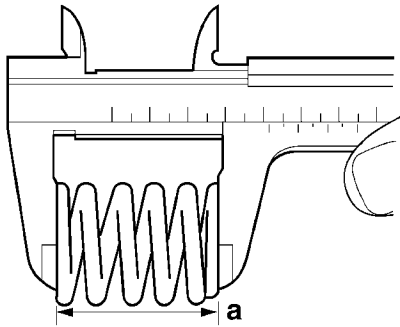

2. Measure:
- Compressed valve spring force "a"
Out of specification → Replace the valve spring.

 **Installed compression spring force (intake)**
171.00–197.00 N (17.44–20.09 kgf, 38.44–44.29 lbf)
Installed compression spring force (exhaust)
171.00–197.00 N (17.44–20.09 kgf, 38.44–44.29 lbf)
Installed length (intake)
35.00 mm (1.38 in)
Installed length (exhaust)
35.00 mm (1.38 in)

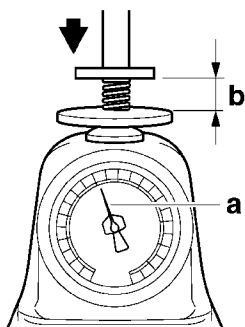

b. Installed length

3. Measure:
- Valve spring tilt "a"
Out of specification → Replace the valve spring.

 **Spring tilt (intake)**
2.5°/1.80 mm (2.5°/0.07 in)
Spring tilt (exhaust)
2.5°/1.80 mm (2.5°/0.07 in)

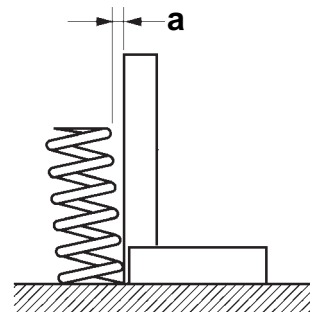

EAS24340

INSTALLING THE VALVES

The following procedure applies to all of the valves and related components.

1. Deburr:
- Valve stem end
(with an oil stone)

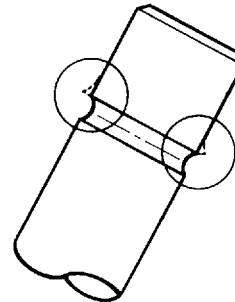

2. Lubricate:
- Valve stem "1"
 - Valve stem seal "2" **New**
(with the recommended lubricant)

 **Recommended lubricant**
Molybdenum disulfide oil

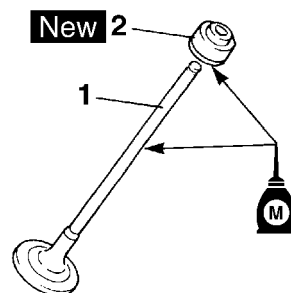

3. Install:
- Valve spring seat "1"
 - Valve stem seal "2" **New**

VALVES AND VALVE SPRINGS

- Valve "3"
- Valve spring "4"
- Valve spring retainer "5"
(into the cylinder head)

TIP

- Make sure each valve is installed in its original place.
- Install the valve springs with the larger pitch "a" facing up.

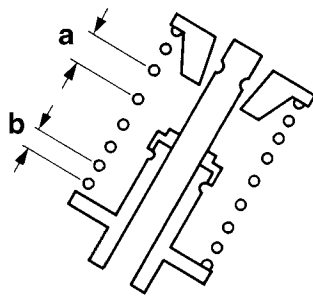
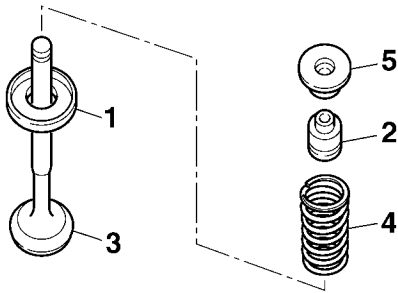

b. Smaller pitch

4. Install:

- Valve cotters

TIP

Install the valve cotters by compressing the valve spring with the valve spring compressor "1" and the valve spring compressor attachment "2".

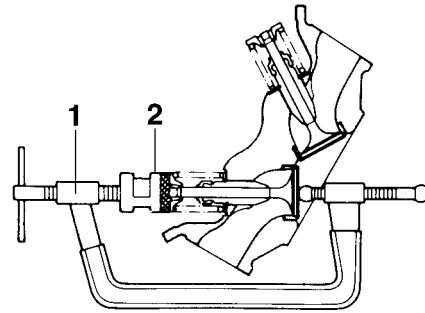

5. To secure the valve cotters onto the valve stem, lightly tap the valve tip with a soft-face hammer.

ECA13800

NOTICE

Hitting the valve tip with excessive force could damage the valve.

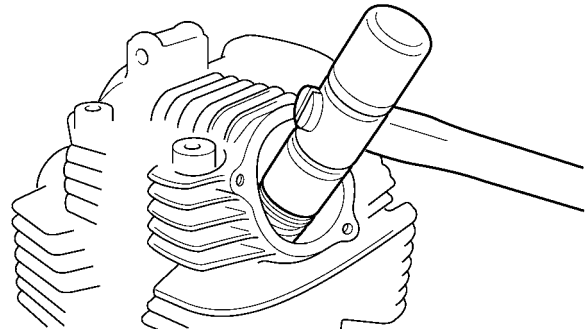

Valve spring compressor

90890-04019

YM-04019

Valve spring compressor attachment

90890-01243

Valve spring compressor adapter (26 mm)

YM-01253-1

EAS24350

CYLINDER AND PISTON

Removing the cylinder and piston

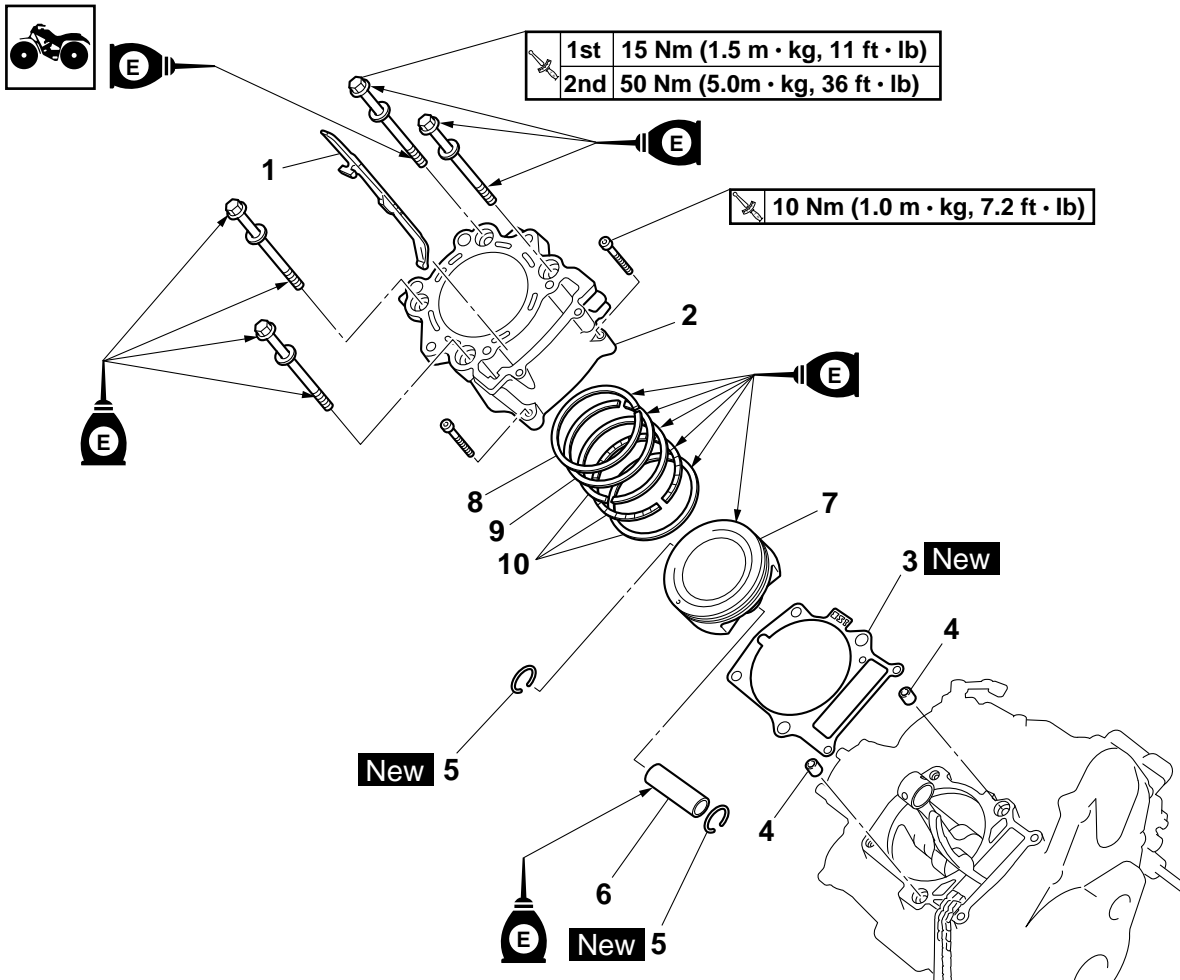

Order	Job/Parts to remove	Q'ty	Remarks
	Cylinder head		Refer to "CYLINDER HEAD" on page 5-10.
	Water jacket joint		Refer to "WATER PUMP" on page 6-7.
1	Timing chain guide (exhaust side)	1	
2	Cylinder	1	
3	Cylinder gasket	1	
4	Dowel pin	2	
5	Piston pin clip	2	
6	Piston pin	1	
7	Piston	1	
8	Top ring	1	
9	2nd ring	1	
10	Oil ring	1	
			For installation, reverse the removal procedure.

CYLINDER AND PISTON

EAS24380

REMOVING THE PISTON

1. Remove:

- Piston pin clips "1"
- Piston pin "2"
- Piston "3"

ECA13810

NOTICE

Do not use a hammer to drive the piston pin out.

TIP

- Before removing the piston pin clips, cover the crankcase opening with a clean rag to prevent the piston pin clips from falling into the crankcase.
- Before removing the piston pin, deburr the piston pin clip grooves and the piston pin bore area. If both areas are deburred and the piston pin is still difficult to remove, remove it with the piston pin puller set "4".



Piston pin puller set
90890-01304
Piston pin puller
YU-01304

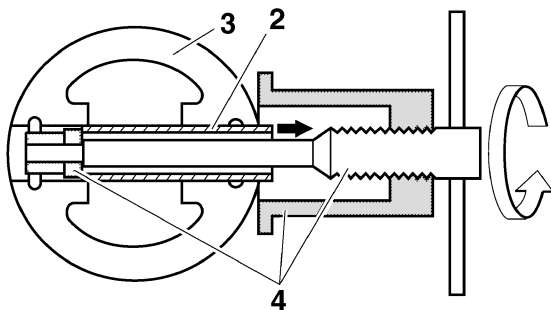
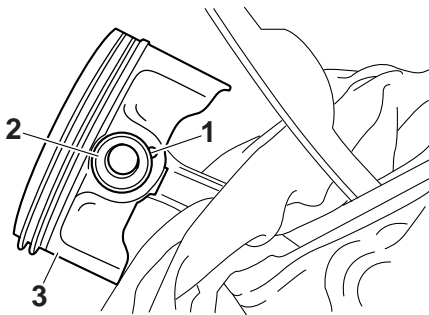

2. Remove:

- Top ring
- 2nd ring
- Oil ring

TIP

When removing a piston ring, open the end gap with your fingers and lift the other side of the ring over the piston crown.

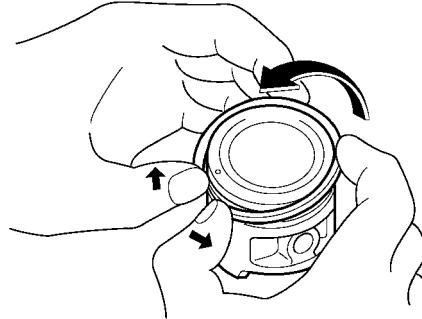

EAS24400

CHECKING THE CYLINDER AND PISTON

1. Check:

- Piston wall
- Cylinder wall

Vertical scratches → Replace the cylinder, and replace the piston and piston rings as a set.

2. Measure:

- Piston-to-cylinder clearance

a. Measure cylinder bore with the cylinder bore gauge.

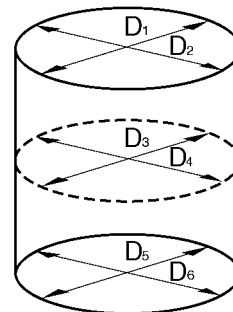

TIP

Measure cylinder bore by taking side-to-side and front-to-back measurements of the cylinder. Then, find the average of the measurements.



Bore
102.000–102.010 mm (4.0157–4.0161 in)
Wear limit
102.080 mm (4.0189 in)
Taper limit
0.05 mm (0.002 in)
Out of round limit
0.05 mm (0.002 in)

CYLINDER AND PISTON

Bore = maximum of D_1 – D_6
Taper limit = maximum of D_1 or D_2 - maximum of D_5 or D_6
Out of round limit = maximum of D_1 , D_3 or D_5 - minimum of D_2 , D_4 or D_6

- b. If out of specification, replace the cylinder, and replace the piston and piston rings as a set.
- c. Measure piston skirt diameter “a” with the micrometer.

	Piston skirt diameter 101.955–101.970 mm (4.0140–4.0146 in)
---	---

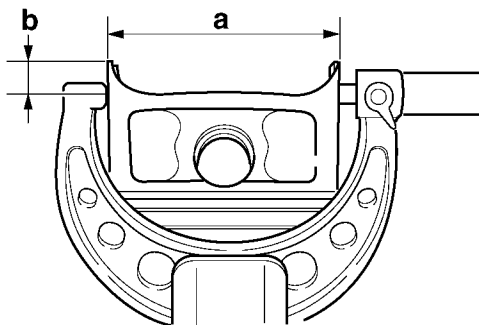

- b. 10 mm (0.39 in) from the bottom edge of the piston
- d. If out of specification, replace the piston and piston rings as a set.
- e. Calculate the piston-to-cylinder clearance with the following formula.

• Piston-to-cylinder clearance = Cylinder bore - Piston skirt diameter

	Piston-to-cylinder clearance 0.030–0.055 mm (0.0012–0.0022 in) Limit 0.13 mm (0.0051 in)
---	---

- f. If out of specification, replace the cylinder, and replace the piston and piston rings as a set.



EAS24430

CHECKING THE PISTON RINGS

1. Measure:
 - Piston ring side clearance
Out of specification → Replace the piston and piston rings as a set.

TIP

Before measuring the piston ring side clearance, eliminate any carbon deposits from the piston ring grooves and piston rings.



Top ring Ring side clearance 0.030–0.070 mm (0.0012–0.0028 in) Limit 0.12 mm (0.0047 in)
2nd ring Ring side clearance 0.030–0.070 mm (0.0012–0.0028 in) Limit 0.13 mm (0.0051 in)
Oil ring Ring side clearance 0.060–0.150 mm (0.0024–0.0059 in)

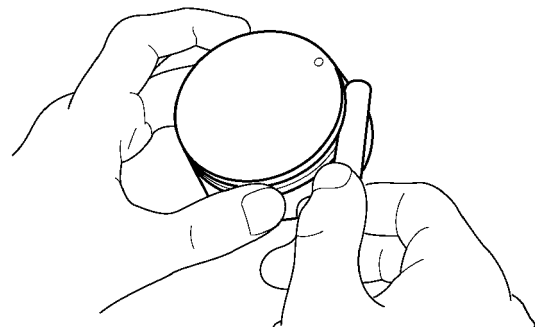

2. Install:
 - Piston ring
(into the cylinder)

TIP

Level the piston ring into the cylinder with the piston crown.

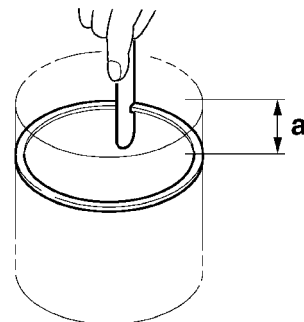

- a. 50 mm (1.97 in)

CYLINDER AND PISTON

3. Measure:

- Piston ring end gap
Out of specification → Replace the piston ring.

TIP

The oil ring expander spacer end gap cannot be measured. If the oil ring rail gap is excessive, replace all three piston rings.



Top ring
End gap (installed)
0.20–0.35 mm (0.008–0.014 in)
Limit
0.60 mm (0.024 in)
2nd ring
End gap (installed)
0.75–0.90 mm (0.03–0.04 in)
Limit
1.25 mm (0.049 in)
Oil ring
End gap (installed)
0.20–0.70 mm (0.01–0.03 in)

EAS24440

CHECKING THE PISTON PIN

1. Check:

- Piston pin
Blue discoloration/grooves → Replace the piston pin and then check the lubrication system.

2. Measure:

- Piston pin outside diameter “a”
Out of specification → Replace the piston pin.



Piston pin outside diameter
22.991–23.000 mm (0.9052–0.9055 in)
Limit
22.971 mm (0.9044 in)

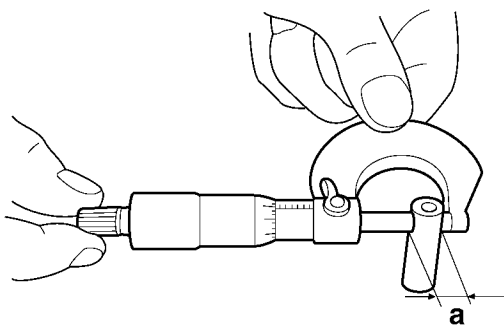

3. Measure:

- Piston pin bore diameter “b”
Out of specification → Replace the piston.



Piston pin bore inside diameter
23.004–23.015 mm (0.9057–0.9061 in)
Limit
23.045 mm (0.9073 in)

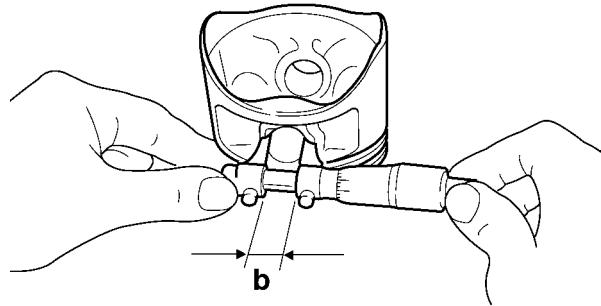

4. Calculate:

- Piston-pin-to-piston-pin-bore clearance
Out of specification → Replace the piston pin and piston as a set.

• Piston-pin-to-piston-pin-bore clearance =
Piston pin bore diameter “b” -
Piston pin outside diameter “a”



Piston-pin-to-piston-pin-bore clearance
0.004–0.024 mm (0.0002–0.0009 in)
Limit
0.0740 mm (0.0029 in)

EAS24450

INSTALLING THE PISTON AND CYLINDER

1. Install:

- Lower oil ring rail “1”
- Oil ring expander “2”
- Upper oil ring rail “3”
- 2nd ring “4”
- Top ring “5”

TIP

Be sure to install the piston rings so that the manufacturer’s marks or numbers face up.

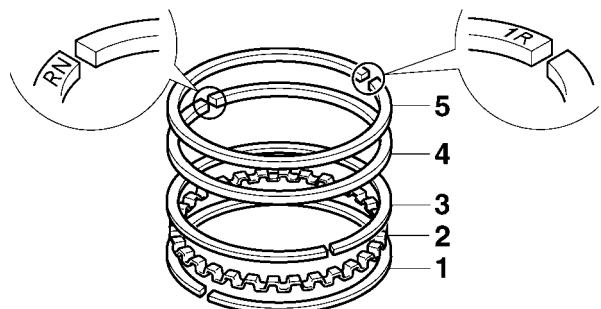

CYLINDER AND PISTON

2. Install:

- Piston "1"
- Piston pin "2"
- Piston pin clips "3" **New**

TIP

- Apply engine oil to the piston pin.
- Make sure the punch mark "a" on the piston points towards the exhaust side of the cylinder.
- Before installing the piston pin clips, cover the crankcase opening with a clean rag to prevent the clips from falling into the crankcase.

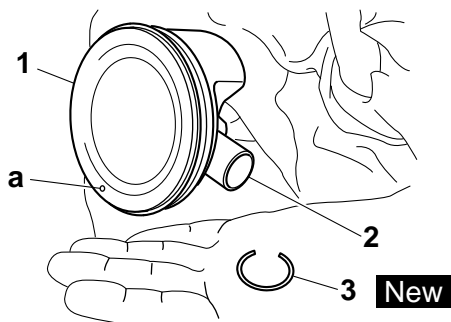

3. Install:

- Cylinder gasket **New**
- Dowel pins

4. Lubricate:

- Piston
- Piston rings
- Cylinder
(with the recommended lubricant)



5. Offset:

- Piston ring end gaps

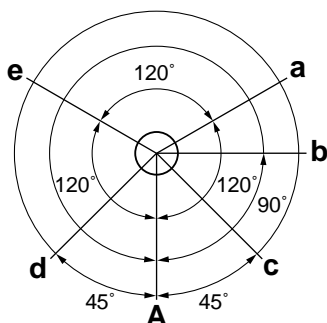

- a. Top ring
- b. Oil ring expander
- c. Upper oil ring rail
- d. Lower oil ring rail
- e. 2nd ring
- A. Exhaust side

6. Install:

- Cylinder "1"
- Timing chain guide (exhaust side)

TIP

- While compressing the piston rings with one hand, install the cylinder with the other hand.
- Pass the timing chain and timing chain guide (exhaust side) through the timing chain cavity.

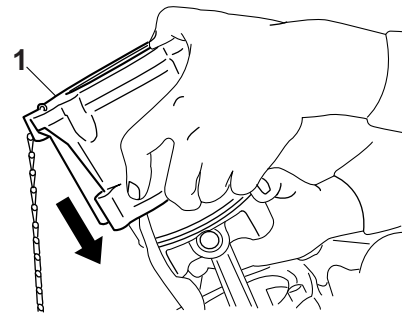

7. Install:

- Cylinder bolts "1"

TIP

Lubricate the cylinder bolt "1" threads and mating surface with engine oil.

8. Tighten:

- Cylinder bolts "1"
- Cylinder bolts (timing chain side) "2"



Cylinder bolt

1st

15 Nm (1.5 m·kg, 11 ft·lb)

2nd

50 Nm (5.0 m·kg, 36 ft·lb)

Cylinder bolt (timing chain side)

10 Nm (1.0 m·kg, 7.2 ft·lb)

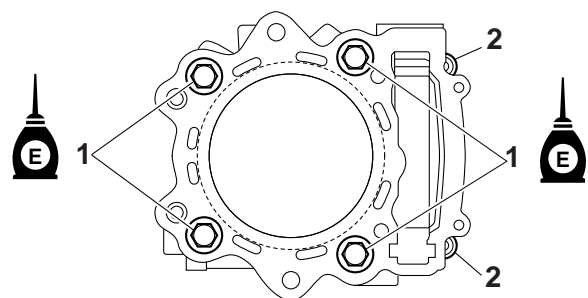

AC MAGNETO AND STARTER CLUTCH

EAS28P1029

AC MAGNETO AND STARTER CLUTCH

Removing the AC magneto and starter clutch

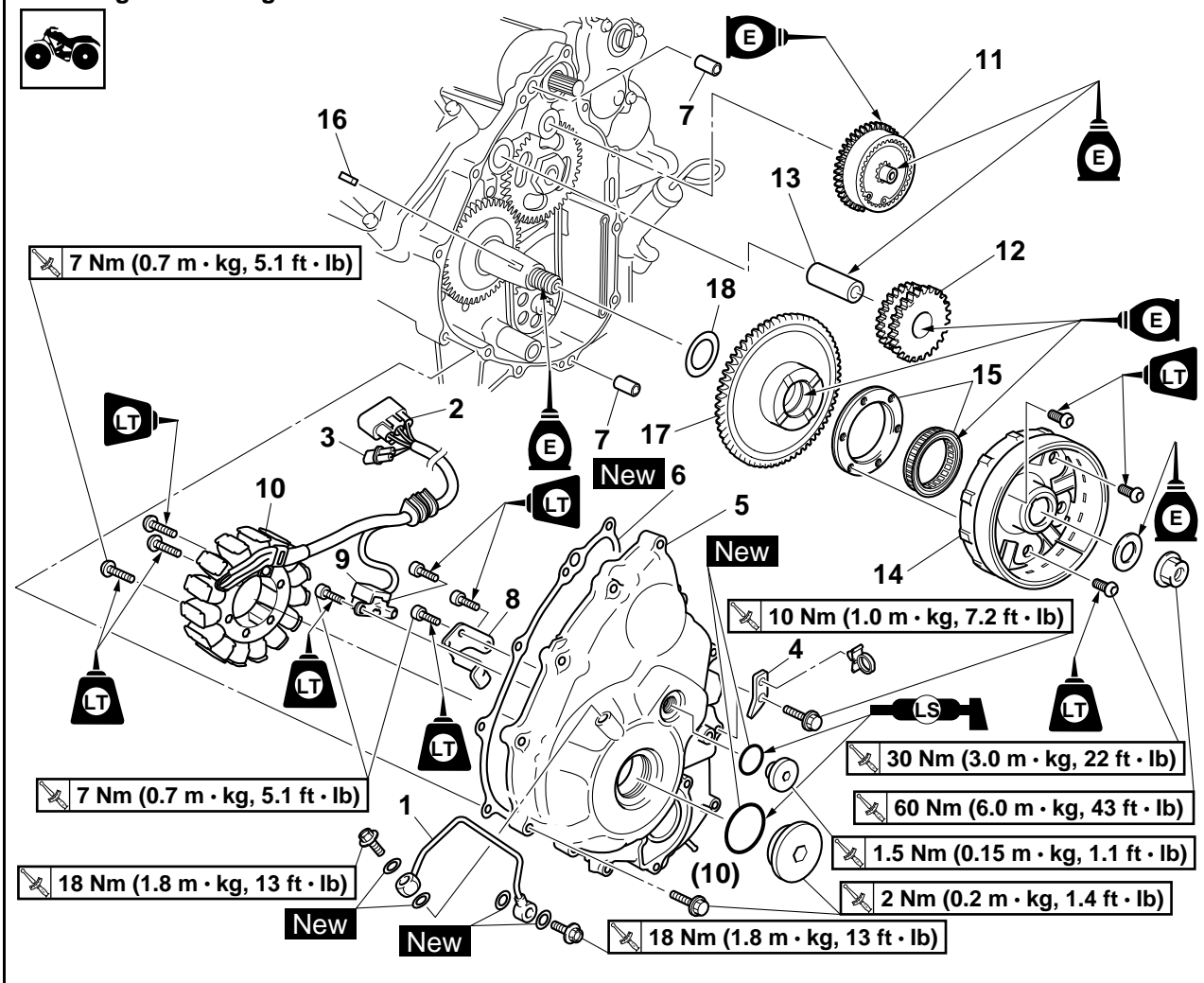

Order	Job/Parts to remove	Q'ty	Remarks
	Engine oil		Drain. Refer to "CHANGING THE ENGINE OIL" on page 3-9.
	Coolant		Drain. Refer to "CHANGING THE COOLANT" on page 3-16.
	Left footrest board		Refer to "GENERAL CHASSIS" on page 4-1.
	Drive select lever unit		Refer to "ENGINE REMOVAL" on page 5-1.
	Water pump		Refer to "WATER PUMP" on page 6-7.
1	Oil delivery pipe 1	1	
2	AC magneto coupler	1	Disconnect.
3	Crankshaft position sensor coupler	1	Disconnect.
4	Lead holder bracket	1	
5	AC magneto cover	1	
6	AC magneto cover gasket	1	
7	Dowel pin	2	
8	Lead holder	1	

AC MAGNETO AND STARTER CLUTCH

Removing the AC magneto and starter clutch

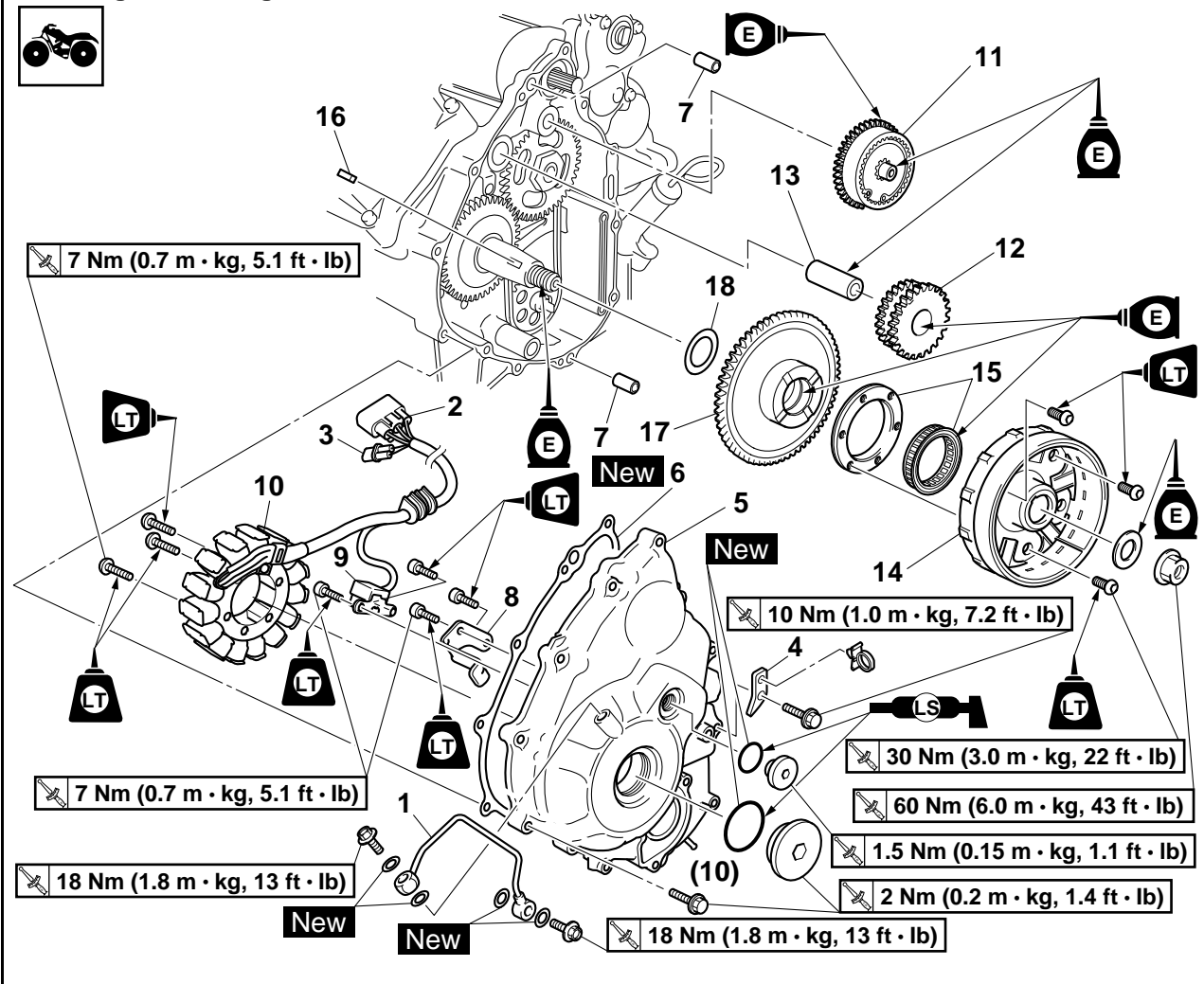

Order	Job/Parts to remove	Q'ty	Remarks
9	Crankshaft position sensor	1	
10	Stator coil	1	
11	Torque limiter	1	
12	Starter idle gear	1	
13	Starter idle gear shaft	1	
14	AC magneto rotor	1	
15	Starter clutch	1	
16	Woodruff key	1	
17	Starter wheel gear	1	
18	Washer	1	
			For installation, reverse the removal procedure.

AC MAGNETO AND STARTER CLUTCH

EAS24490

REMOVING THE AC MAGNETO ROTOR

1. Remove:

- Lead holder bracket "1"
- AC magneto cover

TIP

Loosen each bolt 1/4 of a turn at a time, in stages and in a crisscross pattern. After all of the bolts are fully loosened, remove them.

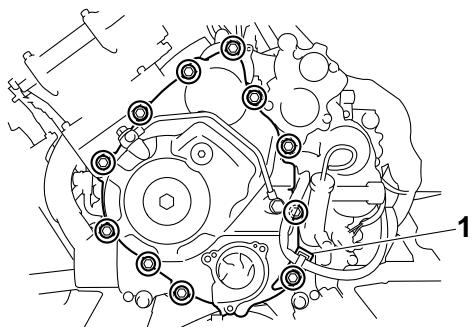

2. Remove:

- AC magneto rotor nut "1"
- Washer

TIP

- Hold the AC magneto rotor "2" with the sheave holder "3" while loosening the AC magneto rotor nut.
- Do not allow the sheave holder to touch the projection on the rotor.



Sheave holder
90890-01701
Primary clutch holder
YS-01880-A

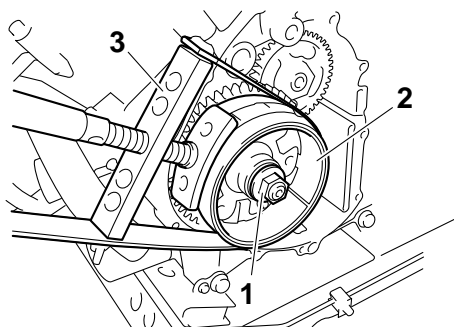

3. Remove:

- AC magneto rotor "1"
(with the starter clutch)
- Woodruff key

ECA13880

NOTICE

To protect the end of the crankshaft, place an appropriate sized socket between the flywheel puller set center bolt and the crankshaft.

TIP

- Use the flywheel puller "2".
- Install the flywheel puller bolts to the threaded holes of the starter clutch.
- Make sure the flywheel puller is centered over the AC magneto rotor.



Flywheel puller
90890-01362
Heavy duty puller
YU-33270-B

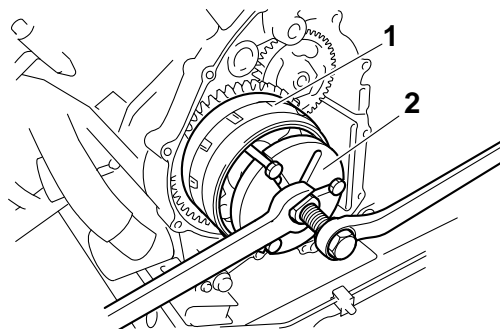

EAS24560

REMOVING THE STARTER CLUTCH

1. Remove:

- Starter clutch bolts "1"

TIP

- Hold the AC magneto rotor "2" with the sheave holder "3" while removing the starter clutch bolts.
- Do not allow the sheave holder to touch the projection on the AC magneto rotor.



Sheave holder
90890-01701
Primary clutch holder
YS-01880-A

AC MAGNETO AND STARTER CLUTCH

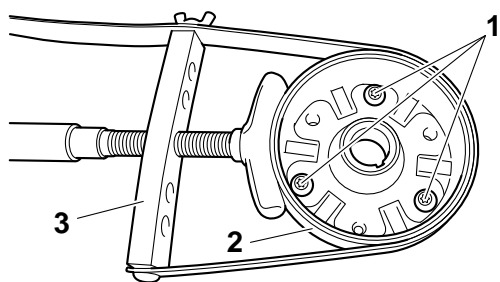

- AC magneto rotor
- Washer
- AC magneto rotor nut

TIP

- Clean the tapered portion of the crankshaft and the AC magneto rotor hub.
- When installing the AC magneto rotor, make sure the woodruff key is properly seated in the keyway of the crankshaft.

EAS28P1068

INSTALLING THE AC MAGNETO

1. Install:

- Stator coil "1"



Stator coil bolt
7 Nm (0.7 m·kg, 5.1 ft·lb)
LOCTITE®

TIP

Align the projection "a" on the stator coil with the slot "b" in the AC magneto cover.

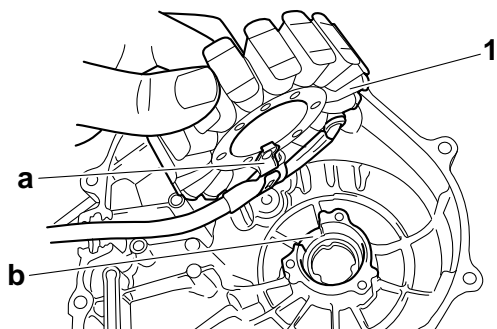

2. Apply:

- Sealant "1"
 (onto the crankshaft position sensor/stator assembly lead grommet)



Yamaha bond No. 1215
90890-85505
(Three Bond No.1215®)

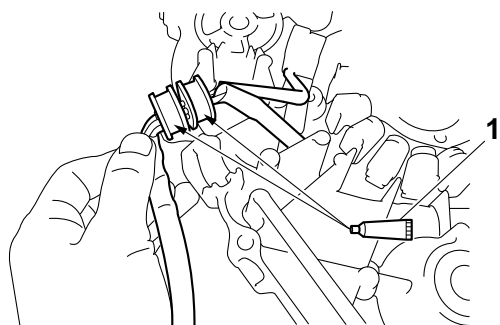

3. Install:

- Woodruff key

4. Tighten:

- AC magneto rotor nut "1"



AC magneto rotor nut
60 Nm (6.0 m·kg, 43 ft·lb)

TIP

- Hold the AC magneto rotor "2" with the sheave holder "3" while tightening the AC magneto rotor nut.
- Do not allow the sheave holder to touch the projection on the AC magneto rotor.



Sheave holder
90890-01701
Primary clutch holder
YS-01880-A

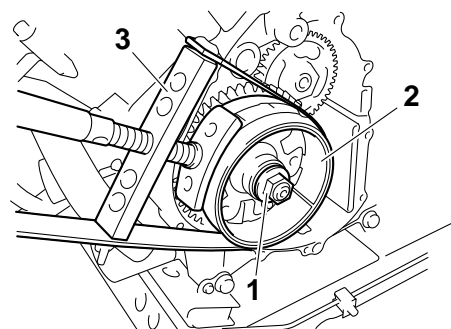

5. Install:

- AC magneto cover
- Lead holder bracket "1"
- AC magneto cover bolts



AC magneto cover bolt
10 Nm (1.0 m·kg, 7.2 ft·lb)

TIP

Tighten the AC magneto cover bolts in stages, using a crisscross pattern.

AC MAGNETO AND STARTER CLUTCH

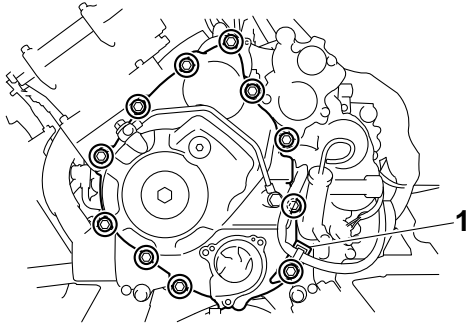

EAS24780

ELECTRIC STARTER

Removing the starter motor

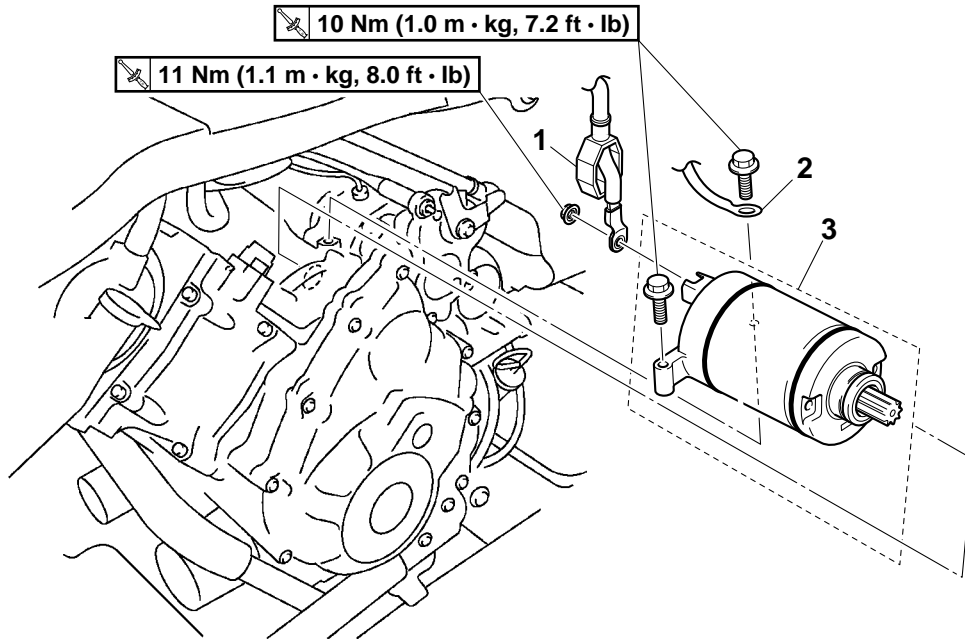

Order	Job/Parts to remove	Q'ty	Remarks
	Muffler		Refer to "ENGINE REMOVAL" on page 5-1.
1	Starter motor lead	1	Disconnect.
2	Ground lead	1	Disconnect.
3	Starter motor	1	
			For installation, reverse the removal procedure.

ELECTRIC STARTER

Disassembling the starter motor

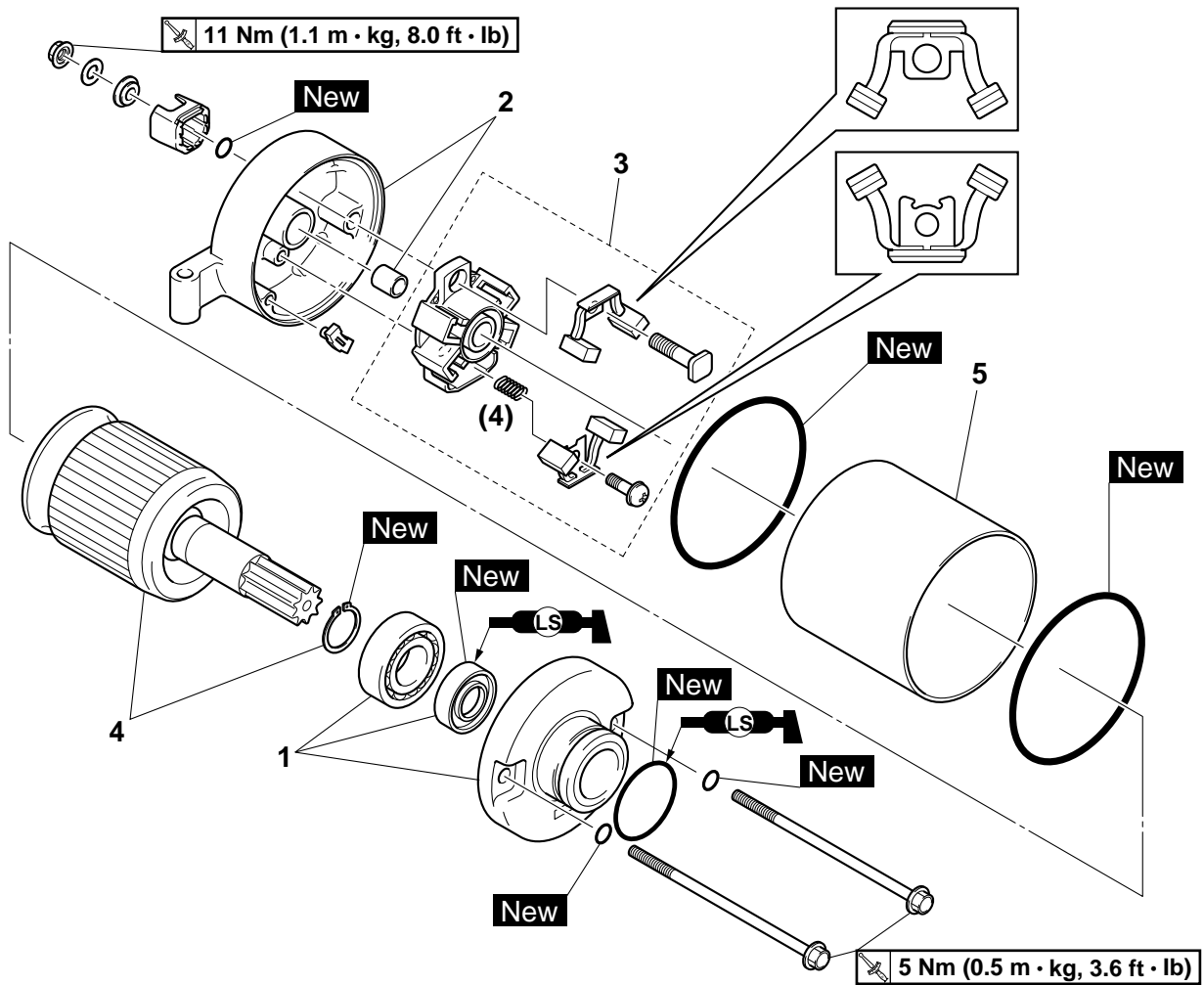

Order	Job/Parts to remove	Q'ty	Remarks
1	Starter motor front cover	1	
2	Starter motor rear cover	1	
3	Brush holder set	1	
4	Armature assembly	1	
5	Starter motor yoke	1	
			For assembly, reverse the disassembly procedure.

ELECTRIC STARTER

EAS24790

CHECKING THE STARTER MOTOR

1. Check:

- Commutator
Dirt → Clean with 600 grit sandpaper.

2. Measure:

- Mica undercut "a"
Out of specification → Cut the mica to the proper measurement with a hacksaw blade that has been grounded to fit the commutator.



Mica undercut (depth)
0.70 mm (0.03 in)

TIP

The mica of the commutator must be undercut to ensure proper operation of the commutator.

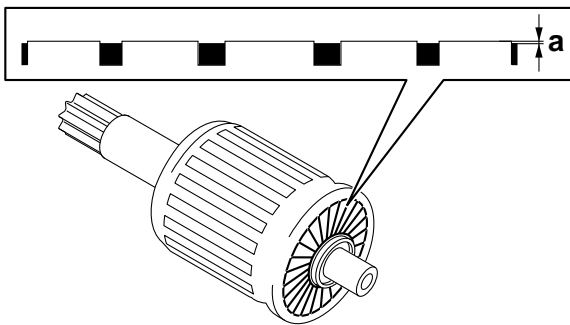

3. Measure:

- Armature assembly resistances (commutator and insulation)
Out of specification → Replace the starter motor.

a. Measure the armature assembly resistances with the digital circuit tester.



Digital circuit tester
90890-03174
Model 88 Multimeter with tachometer
YU-A1927



Armature coil
Commutator resistance "1"
0.0050–0.0150 Ω at 20 °C (68 °F)
Insulation resistance "2"
Above 1 MΩ at 20 °C (68 °F)

b. If any resistance is out of specification, replace the starter motor.

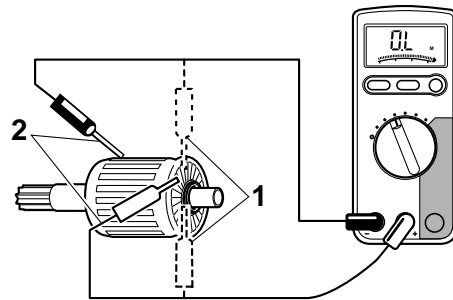

4. Measure:

- Brush length "a"
Out of specification → Replace the brushes as a set.



Brush overall length
12.0 mm (0.47 in)
Limit
6.50 mm (0.26 in)

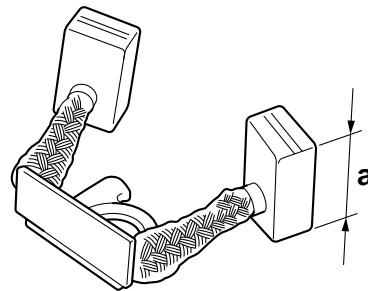

5. Measure:

- Brush spring force
Out of specification → Replace the brush springs as a set.



Brush spring force
6.02–6.51 N (614–664 gf, 21.69–23.45 oz)

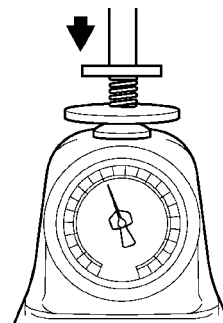

6. Check:

- Gear teeth
Damage/wear → Replace the gear.

7. Check:

- Bearing
 - Oil seal
- Damage/wear → Replace the defective part(s).

EAS24800

ASSEMBLING THE STARTER MOTOR

1. Install:

- Starter motor yoke "1"
- Starter motor front cover "2"
- Starter motor rear cover "3"

TIP _____

Align the alignment marks "a" on the starter motor yoke with the match marks "b" on the front and starter motor rear covers.

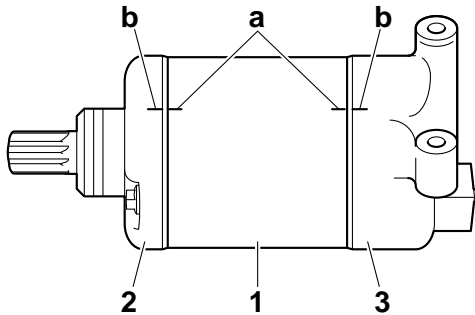

BALANCER GEARS AND OIL PUMP GEARS

EAS28P1040

BALANCER GEARS AND OIL PUMP GEARS

Removing the balancer gears and oil pump gears

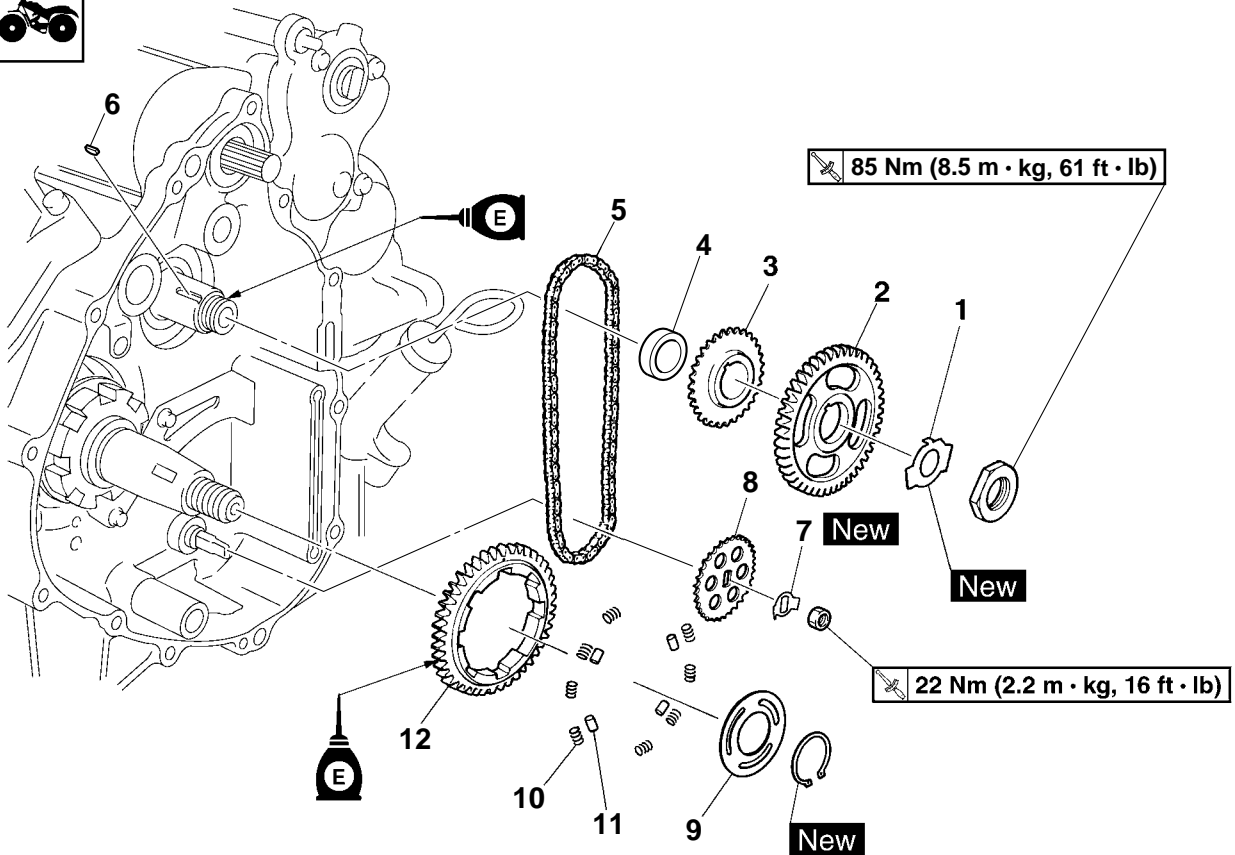

Order	Job/Parts to remove	Q'ty	Remarks
	Starter wheel gear		Refer to "AC MAGNETO AND STARTER CLUTCH" on page 5-33.
1	Lock washer	1	
2	Balancer driven gear	1	
3	Oil pump drive gear	1	
4	Collar	1	
5	Chain	1	
6	Straight key	1	
7	Lock washer	1	
8	Oil pump driven gear	1	
9	Plate	1	
10	Spring	8	
11	Pin	4	
12	Balancer drive gear	1	
			For installation, reverse the removal procedure.

BALANCER GEARS AND OIL PUMP GEARS

EAS28P1041

REMOVING THE BALANCER DRIVEN GEAR AND OIL PUMP DRIVEN GEAR

1. Straighten the lock washer tabs.
2. Loosen:
 - Balancer driven gear nut “1”
 - Oil pump driven gear nut “2”

TIP

Place an aluminum plate “3” between the teeth of the balancer drive gear “4” and balancer driven gear “5”, then loosen the nuts.

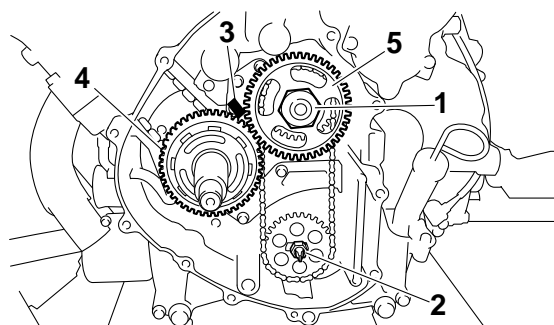

EAS28P1042

CHECKING THE OIL PUMP DRIVE

1. Check:
 - Oil pump drive gear
 - Oil pump driven gearCracks/wear/damage → Replace.

EAS28P1043

CHECKING THE BALANCER DRIVE

1. Check:
 - Balancer drive gear
 - Balancer driven gearDamage/wear → Replace the balancer drive gear and balancer driven gear as a set.
Excessive noise during operation → Replace the balancer drive gear and balancer driven gear as a set.

EAS28P1044

INSTALLING THE BALANCER DRIVE GEAR, BALANCER DRIVEN GEAR, AND OIL PUMP DRIVEN GEAR

1. Install:
 - Pin
 - Spring
 - Balancer drive gear (onto the buffer boss)

TIP

Align the punch mark “a” on the balancer drive gear with the hole “b” to the buffer boss.

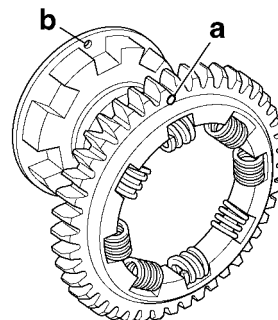

2. Install:
 - Balancer drive gear “1”
 - Balancer driven gear “2”
 - Oil pump driven gear “3”

TIP

- Align the punch mark “a” on the balancer drive gear with the punch mark “b” on the balancer driven gear.
- Install the oil pump driven gear with the “3B4” mark “c” facing out.

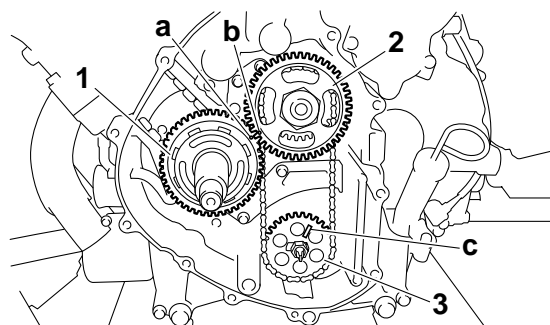

3. Install:
 - Lock washers **New**
 - Oil pump driven gear nut “1”
 - Balancer driven gear nut “2”



Oil pump driven gear nut
22 Nm (2.2 m·kg, 16 ft·lb)
Balancer driven gear nut
85 Nm (8.5 m·kg, 61 ft·lb)

TIP

- Place an aluminum plate “3” between the teeth of the balancer drive gear “4” and balancer driven gear “5”, then tighten the nuts.
- Apply the engine oil to the thread of axles and nuts.

BALANCER GEARS AND OIL PUMP GEARS

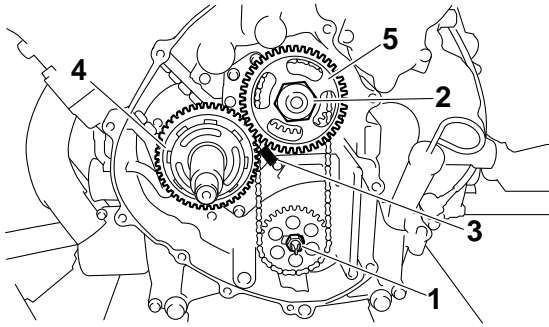

4. Bend the lock washer tabs along the balancer driven gear nut and oil pump driven gear nut.

PRIMARY AND SECONDARY SHEAVES

EAS28P1045

PRIMARY AND SECONDARY SHEAVES

Removing the primary and secondary sheaves

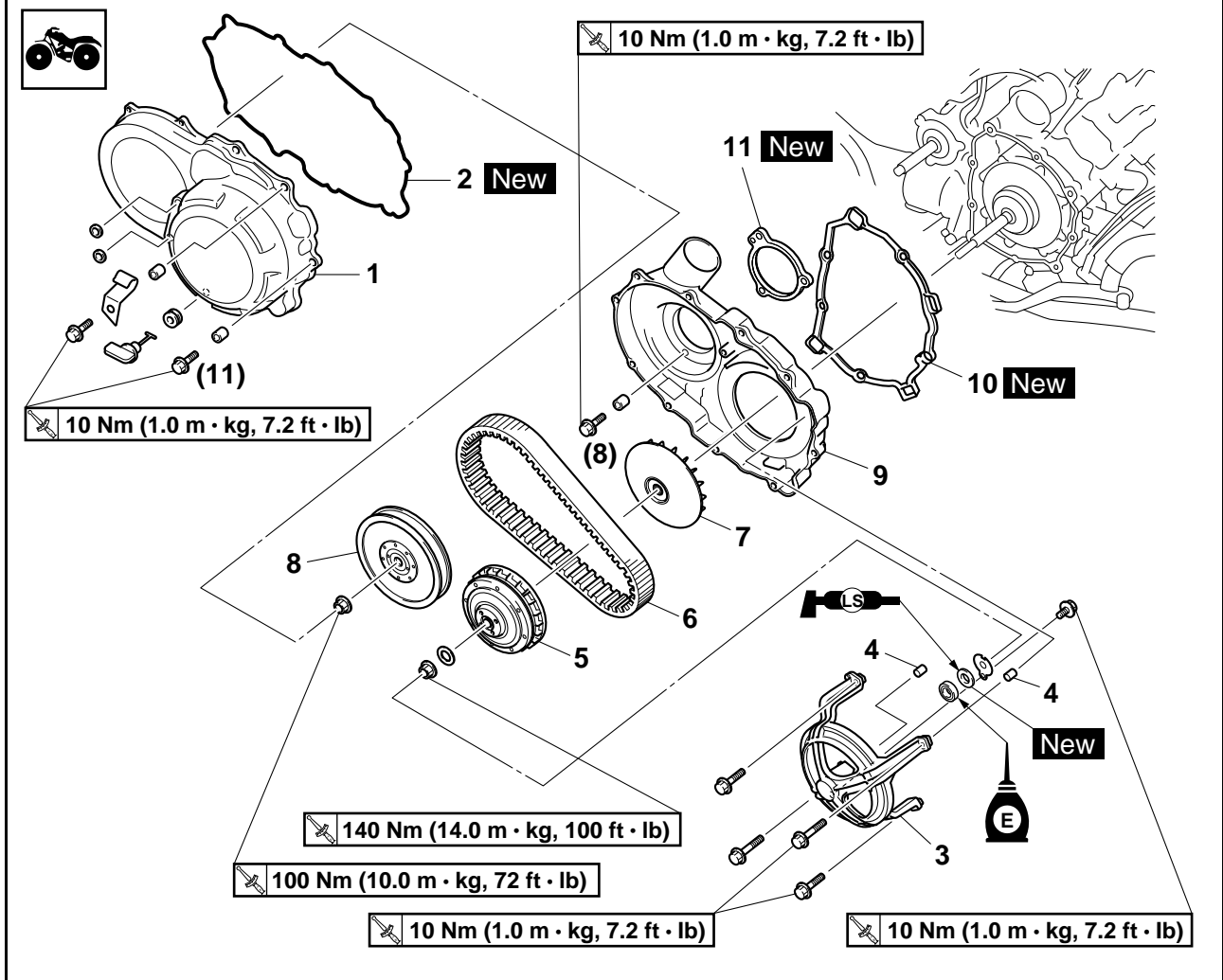

Order	Job/Parts to remove	Q'ty	Remarks
	Front fender/Rear fender/Right footrest board		Refer to "GENERAL CHASSIS" on page 4-1.
	V-belt cooling ducts		Refer to "ENGINE REMOVAL" on page 5-1.
1	Drive belt cover	1	
2	Rubber gasket	1	
3	Bearing housing	1	
4	Dowel pin	2	
5	Primary sheave assembly	1	
6	V-belt	1	
7	Primary fixed sheave	1	
8	Secondary sheave assembly	1	
9	Drive belt case	1	
10	Rubber gasket	1	
11	Rubber gasket	1	
			For installation, reverse the removal procedure.

PRIMARY AND SECONDARY SHEAVES

Disassembling the primary sheave

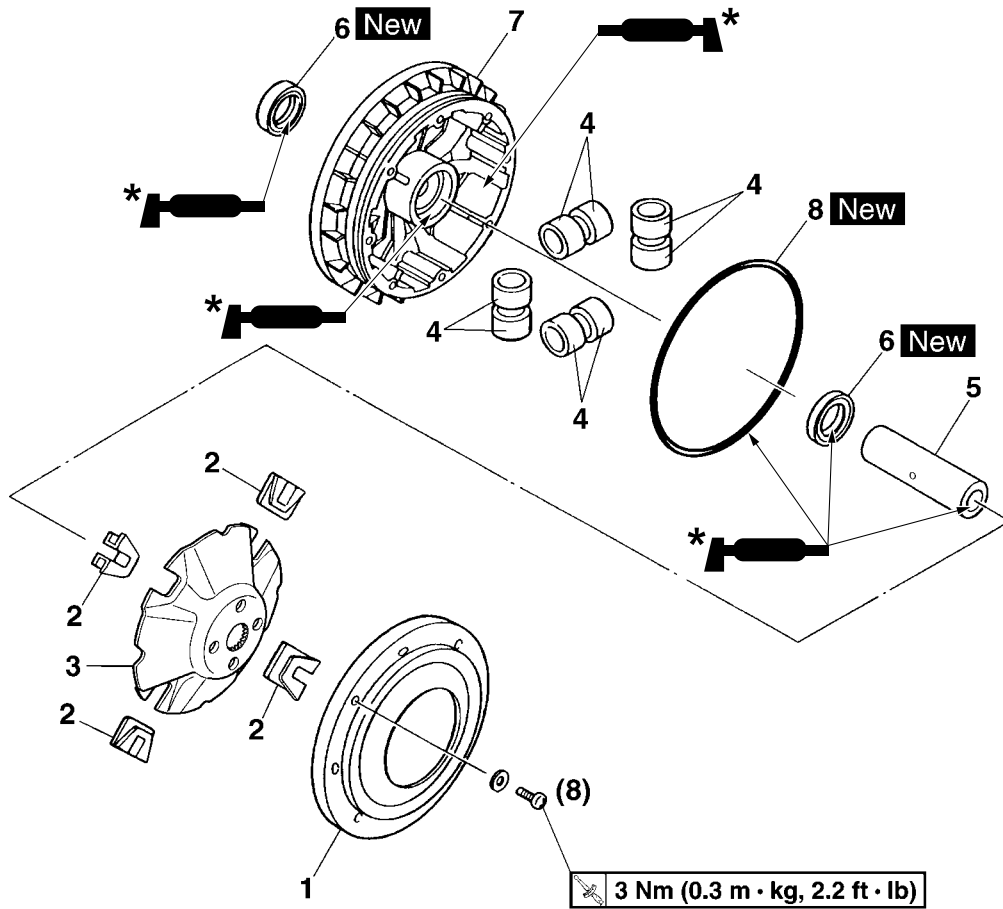

Order	Job/Parts to remove	Q'ty	Remarks
1	Primary sheave cap	1	
2	Primary sheave slider	4	
3	Primary sheave cam	1	
4	Primary sheave weight	8	
5	Collar	1	
6	Oil seal	2	
7	Primary sliding sheave	1	
8	O-ring	1	
			For assembly, reverse the disassembly procedure.

* Apply Yamaha Grizzly grease.

PRIMARY AND SECONDARY SHEAVES

Disassembling the secondary sheave

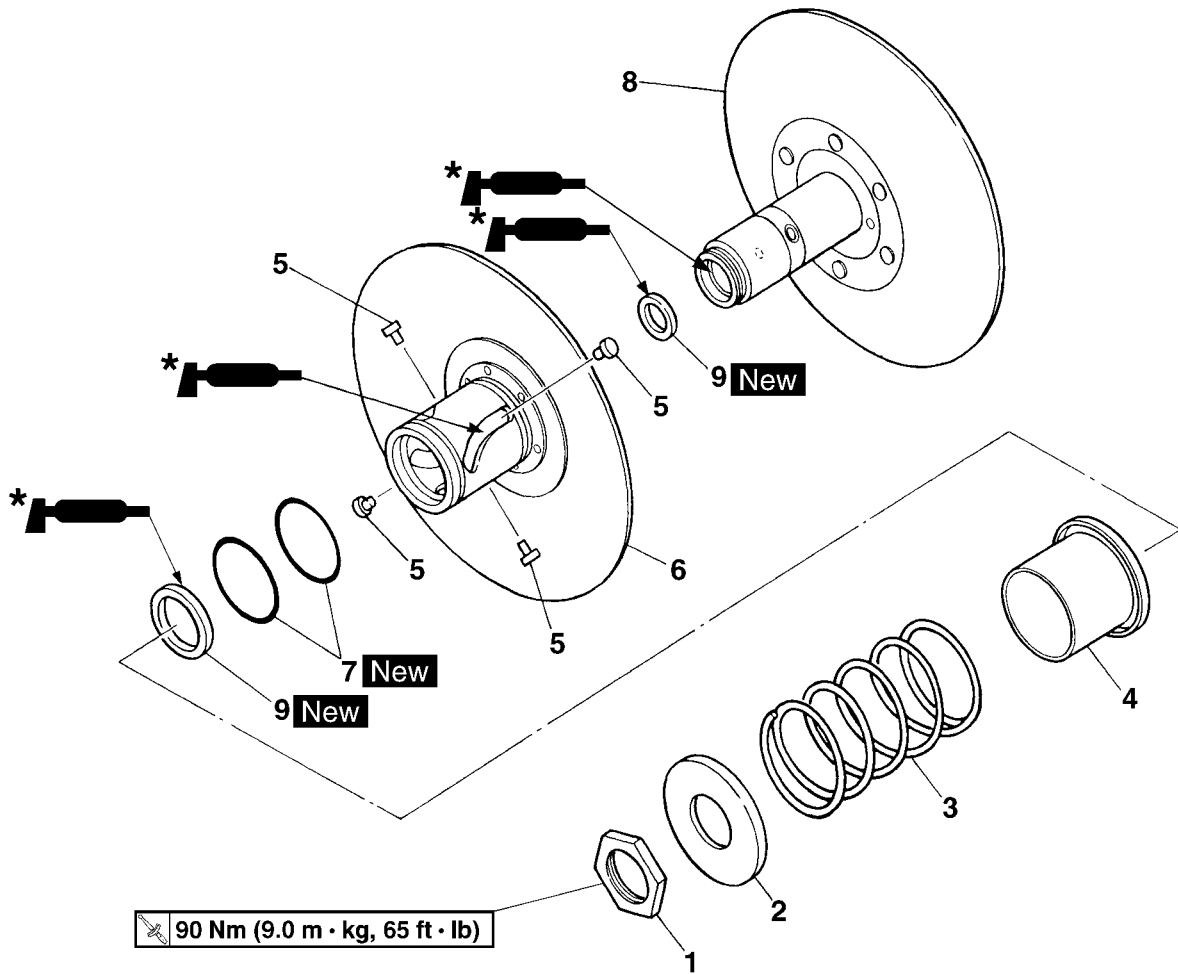

Order	Job/Parts to remove	Q'ty	Remarks
1	Nut	1	
2	Spring seat	1	
3	Compression spring	1	
4	Spring seat	1	
5	Guide pin	4	
6	Secondary sliding sheave	1	
7	O-ring	2	
8	Secondary fixed sheave	1	
9	Oil seal	2	
			For assembly, reverse the disassembly procedure.

* Apply BEL-RAY assembly lube®.

PRIMARY AND SECONDARY SHEAVES

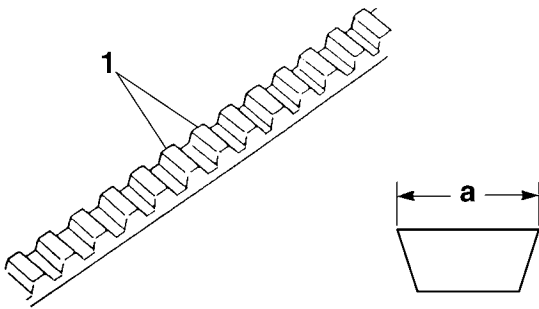

EAS24680

CHECKING THE PRIMARY SHEAVE

1. Check:
 - Primary sliding sheave splines
Wear/cracks/damage → Replace.
 - Primary sheave cam
Cracks/damage → Replace.
2. Check:
 - Primary sliding sheave
 - Primary fixed sheave
Cracks/damage → Replace.

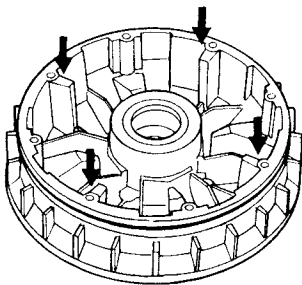

EAS24690

CHECKING THE PRIMARY SHEAVE WEIGHTS

The following procedure applies to all of the primary sheave weights.

1. Check:
 - Primary sheave weight
Cracks/damage/wear → Replace.
2. Measure:
 - Primary sheave weight outside diameter "a"
Out of specification → Replace.



Primary sheave weight outside diameter
30 mm (1.16 in)
Limit
29.5 mm (1.16 in)

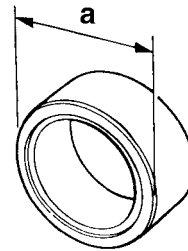

EAS24700

CHECKING THE PRIMARY SHEAVE SLIDERS

The following procedure applies to all of the primary sheave sliders.

1. Check:
 - Primary sheave slider
Cracks/damage/wear → Replace.

EAS24710

CHECKING THE SECONDARY SHEAVE

1. Check:
 - Secondary fixed sheave
 - Secondary sliding sheave
Cracks/damage/wear → Replace the secondary fixed and sliding sheaves as a set.
2. Check:
 - Torque cam grooves "1"
Damage/wear → Replace the secondary fixed and sliding sheaves as a set.
3. Check:
 - Guide pins "2"
Damage/wear → Replace the secondary fixed and sliding sheaves as a set.

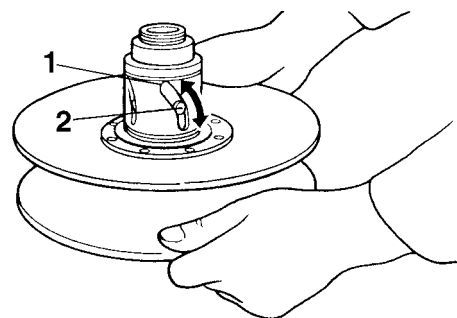

4. Check:
 - Secondary sheave spring
Damage → Replace.
5. Measure:
 - Secondary sheave spring free length "a"
Out of specification → Replace the secondary sheave spring.

PRIMARY AND SECONDARY SHEAVES



Free length
130.6 mm (5.14 in)
Limit
128.0 mm (5.04 in)

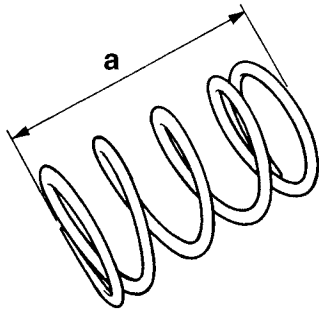

EAS24720

ASSEMBLING THE PRIMARY SHEAVE

1. Clean:

- Primary sliding sheave "1"
- Primary fixed sheave "2"
- Collar "3"
- Primary sheave weights "4"
- Primary sliding sheave cam face

TIP

Remove any excess grease.

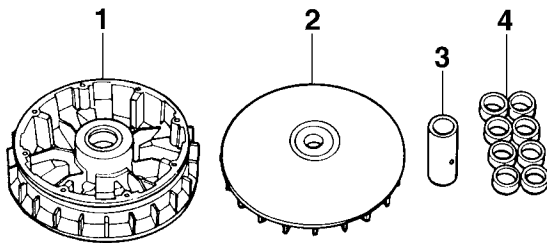

2. Install:

- Oil seals "1" **New**



Installed depth "a"
0 mm (0 in)

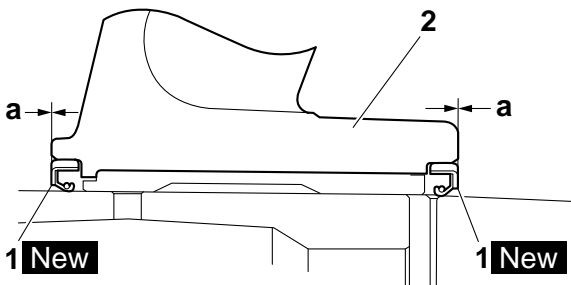

2. Primary sliding sheave

3. Install:

- Primary sheave weights "1"

TIP

- Apply Yamaha Grizzly grease (90 g) to the whole outer surface of the weights and install.
- Apply Yamaha Grizzly grease (2.5 g) to the inner surface of the collar.
- Apply Yamaha Grizzly grease (2.5 g) to the inner surface of the primary sliding sheave.

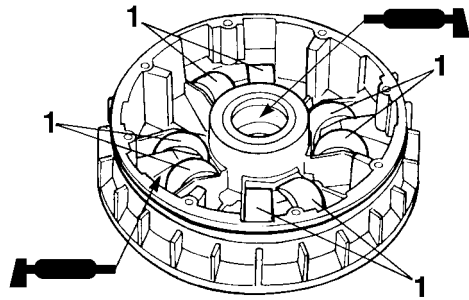

EAS24730

ASSEMBLING THE SECONDARY SHEAVE

1. Install:

- Oil seals "1" **New**



Installed depth "a"
0 mm (0 in)

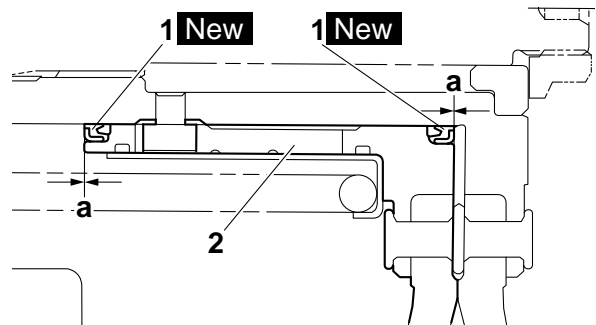

2. Secondary sliding sheave

2. Lubricate:

- Secondary sliding sheave "1"
- Secondary fixed sheave "2"
(with the recommended lubricant)



Recommended lubricant
BEL-RAY assembly lube®

TIP

Apply BEL-RAY assembly lube® (15 g) to the inner surface of the secondary fixed sheave.

PRIMARY AND SECONDARY SHEAVES

TIP

- Be sure to push in the primary sheave cam “1” when installing the primary sheave so that the primary sheave weights “2” will be properly position “a”.
- Tightening the bolts “3” will push the secondary sliding sheave away, causing the gap between the secondary fixed and sliding sheaves to widen.
- Install the V-belt so that its arrow points in the direction of rotation as shown in the illustration.

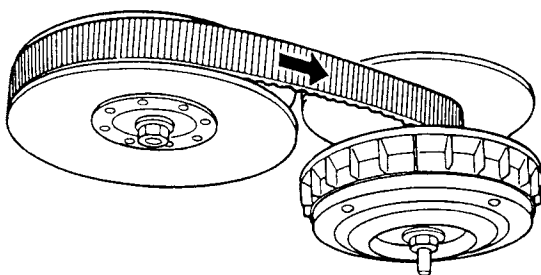
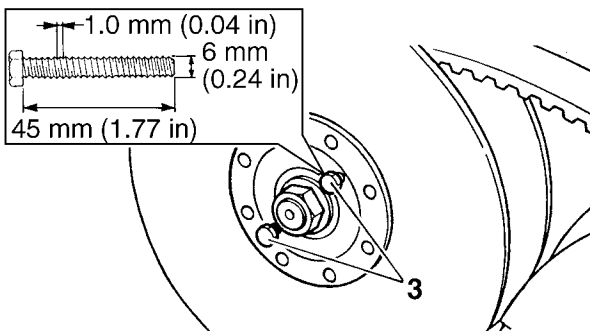
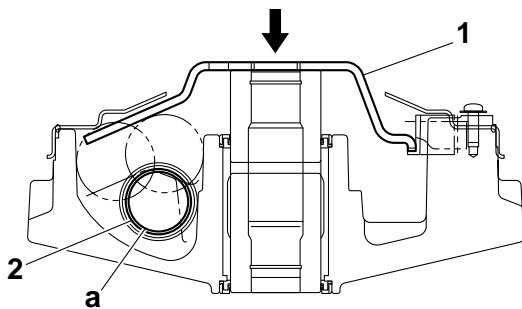

2. Check:

- Primary sheave weights position
Out of specification → Repeat step (1).

TIP

To check that the primary sheave weights “1” are installed correctly, make sure that the secondary sheave “2”, primary sheave “3”, and V-belt “4” are positioned as shown in the illustration.

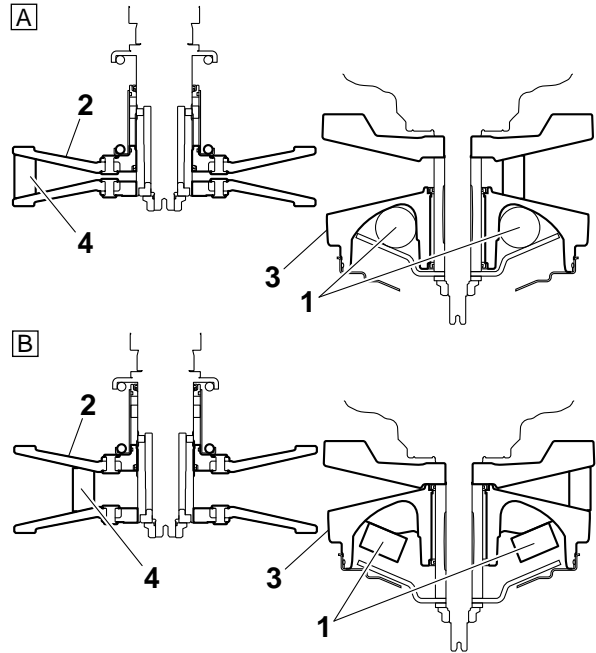

- A. Correct position
B. Incorrect position

3. Tighten:

- Primary sheave nut “1”
- Secondary sheave nut “2”

	<p>Primary sheave nut 140 Nm (14.0 m·kg, 100 ft·lb) Secondary sheave nut 100 Nm (10.0 m·kg, 72 ft·lb)</p>
---	---

TIP

- Use the sheave holder “3” to hold the primary sheave.
- First, tighten the primary sheave nut “1”, then tighten the secondary sheave nut “2”.

	<p>Sheave holder 90890-01701 Primary clutch holder YS-01880-A</p>
---	---

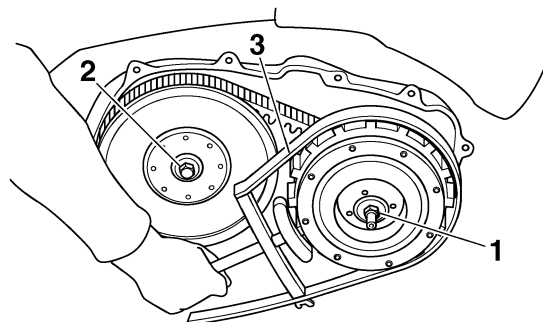

EAS25061

CLUTCH

Removing the clutch

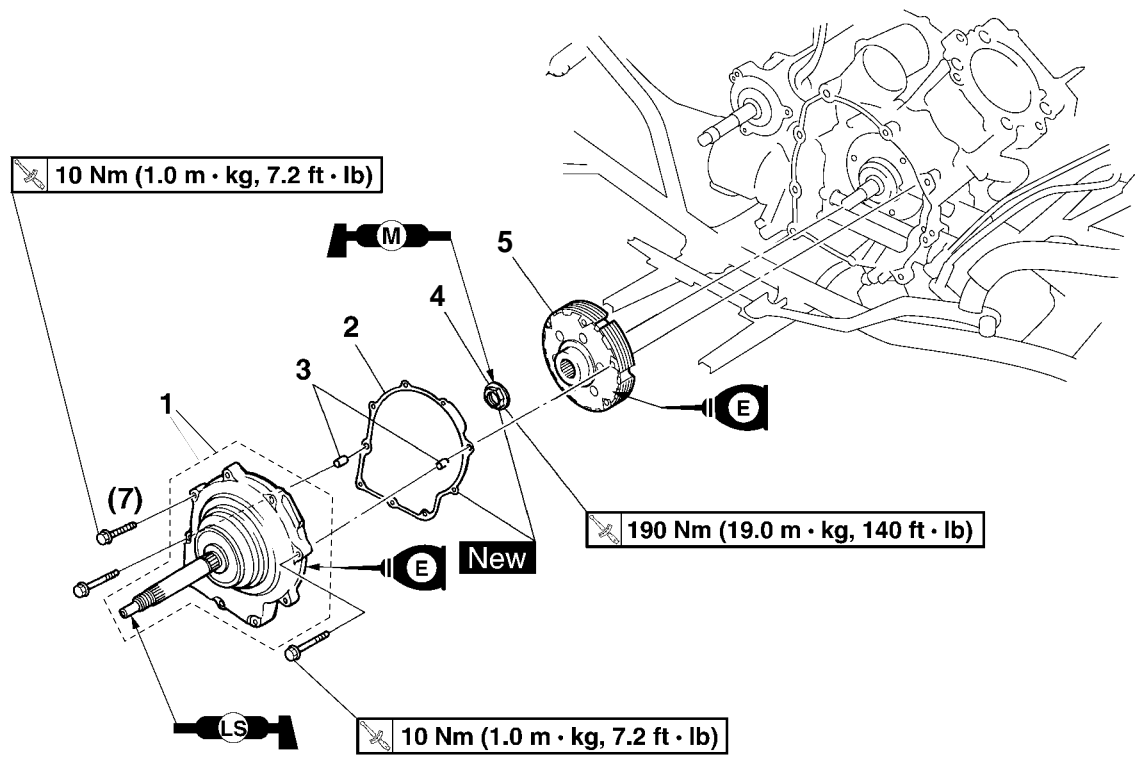

Order	Job/Parts to remove	Q'ty	Remarks
	Primary sheave/Secondary sheave		Refer to "PRIMARY AND SECONDARY SHEAVES" on page 5-46.
1	Clutch housing assembly	1	
2	Gasket	1	
3	Dowel pin	2	
4	Nut	1	
5	Clutch carrier assembly	1	
			For installation, reverse the removal procedure.

Disassembling the clutch housing assembly

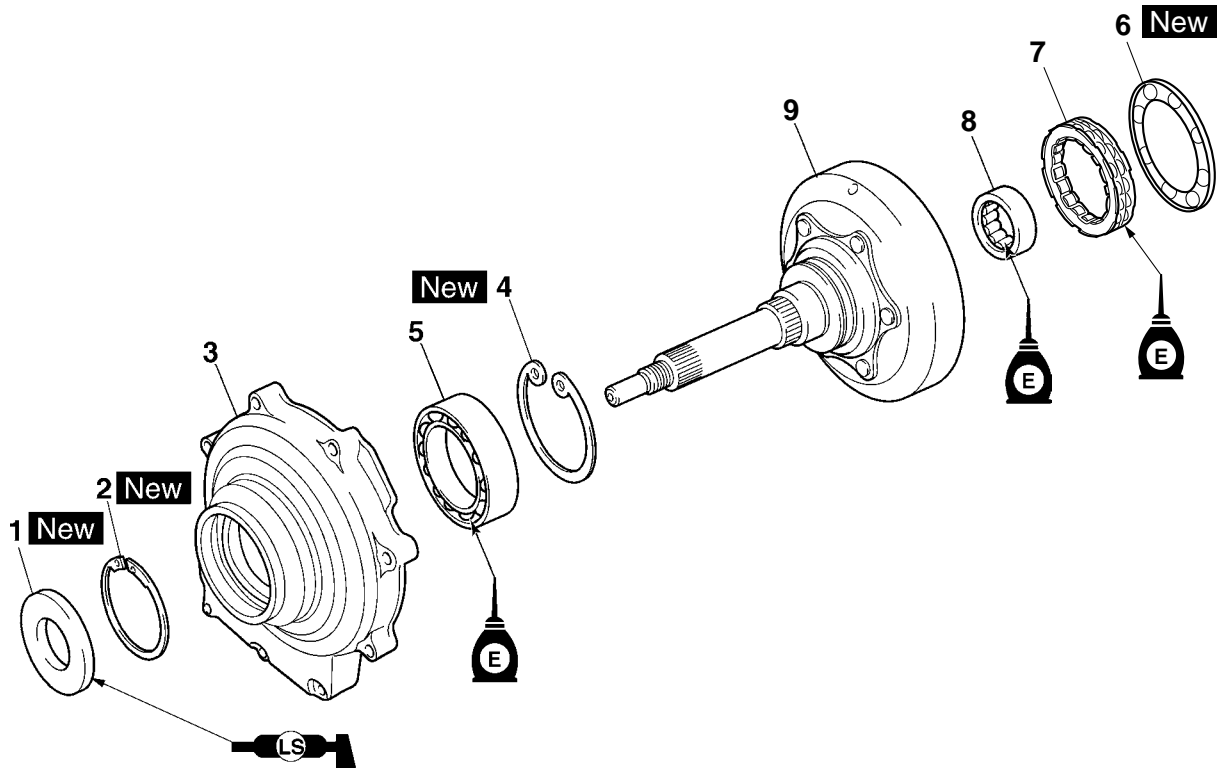

Order	Job/Parts to remove	Q'ty	Remarks
1	Oil seal	1	
2	Circlip	1	
3	Bearing housing	1	
4	Circlip	1	
5	Bearing	1	
6	Seal ring	1	
7	One-way clutch bearing	1	
8	Bearing	1	
9	Clutch housing	1	
			For assembly, reverse the disassembly procedure.

EAS25070

REMOVING THE CLUTCH

1. Remove:

- Clutch housing assembly
- Gasket
- Dowel pins

TIP

Working in crisscross pattern, loosen each bolt 1/4 of a turn. Remove them after all of them are loosened.

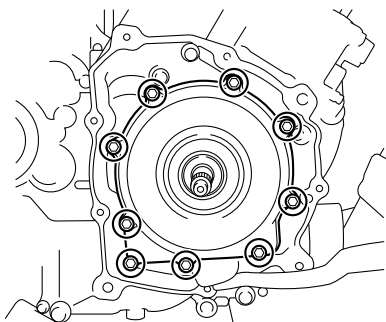

2. Straighten:

- Punched portion "a" of the nut "1"

3. Remove:

- Nut "1"

ECA28P1032

NOTICE

The clutch carrier assembly nut has left-handed threads. To loosen the clutch carrier assembly nut, turn it clockwise.

TIP

Use a clutch holding tool "2" to hold the clutch carrier assembly.



Universal clutch holder
90890-04086
YM-91042

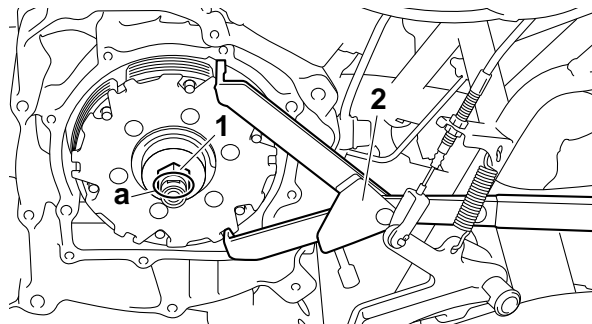

EAS28P1048

CHECKING THE CLUTCH

1. Check:

- Clutch housing
Damage/wear → Replace.

- One-way clutch bearing
Chafing/wear/damage → Replace.

TIP

- Replace the one-way clutch assembly and clutch housing as a set.
- The one-way clutch bearing must be installed with the flange side facing in.

2. Check:

- One-way clutch operation

- Install the one-way clutch bearing and clutch carrier assembly to the clutch housing and hold the clutch carrier assembly.
- When turning the clutch housing clockwise "A", it should turn freely; otherwise, the one-way clutch assembly is faulty and must be replaced.
- When turning the clutch housing counter-clockwise "B", the clutch housing and crankshaft should engage; otherwise, the one-way clutch assembly is faulty and must be replaced.

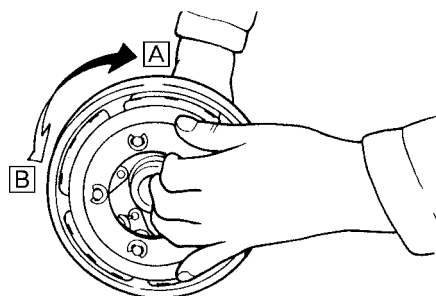

EAS28990

CHECKING THE CLUTCH SHOE

1. Check:

- Clutch shoe
Damage/wear → Replace.
Glazed areas → Sand with coarse sandpaper.

TIP

After sanding the glazed areas, clean the clutch with a cloth.

2. Measure:

- Clutch shoe thickness
Out of specification → Replace.



Clutch shoe thickness
1.5 mm (0.06 in)
Limit
1.0 mm (0.04 in)

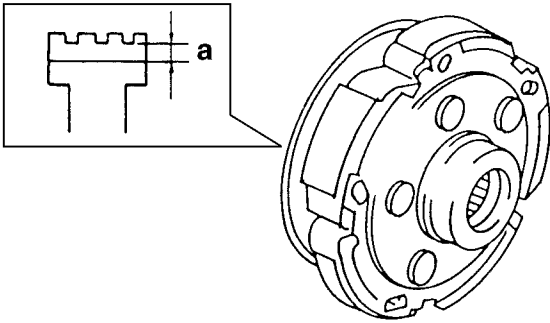

EAS28P1037

ASSEMBLING THE CLUTCH HOUSING

1. Install:

- Bearing "1"

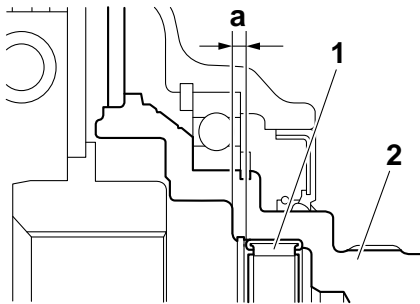
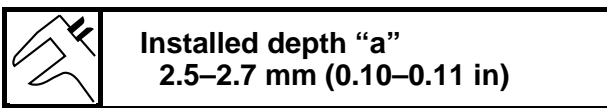

2. Clutch housing

2. Install:

- Oil seal "1" **New**

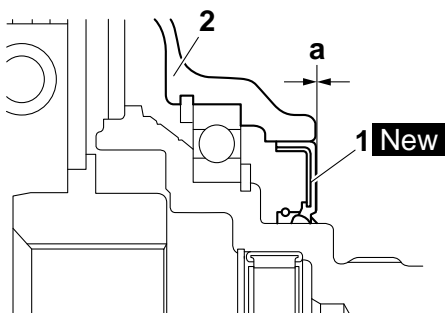
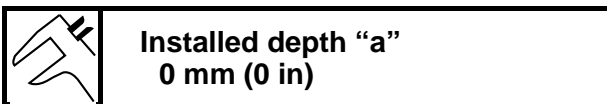

2. Bearing housing

3. Install:

- One-way clutch bearing

TIP

The one-way clutch bearing should be installed in the clutch carrier assembly with the "OUT SIDE" mark "a" facing toward the clutch housing.

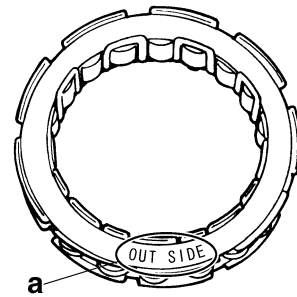

4. Install:

- Seal ring "1" **New**

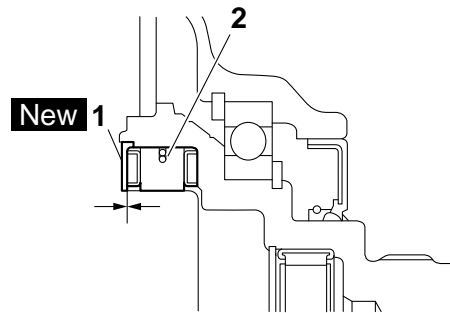

2. One-way clutch bearing

ECA28P1049

INSTALLING THE CLUTCH

1. Install:

- Clutch carrier assembly
- Nut "1" **New**



Clutch carrier assembly nut
190 Nm (19.0 m·kg, 140 ft·lb)

ECA28P1033

NOTICE

The clutch carrier assembly nut has left-handed threads. To tighten the clutch carrier assembly nut, turn it counterclockwise.

TIP

Use a clutch holding tool "2" to hold the clutch carrier assembly.



Universal clutch holder
90890-04086
YM-91042

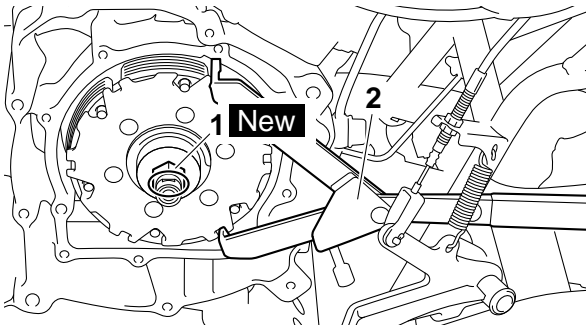

2. Lock the threads with a drift punch.

3. Install:

- Dowel pins
- Gasket **New**
- Clutch housing assembly



Clutch housing assembly bolt
10 Nm (1.0 m·kg, 7.2 ft·lb)

TIP

- Tighten the bolts in stages, using a crisscross pattern.
- After tightening the bolts, check that the clutch housing assembly rotates smoothly.

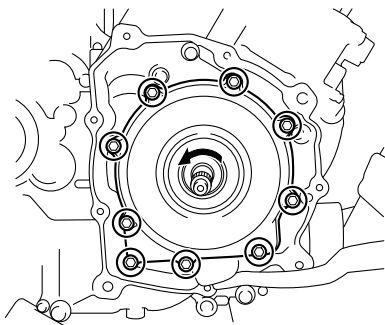

EAS25540

CRANKCASE

Removing the timing chain and oil filter cartridge

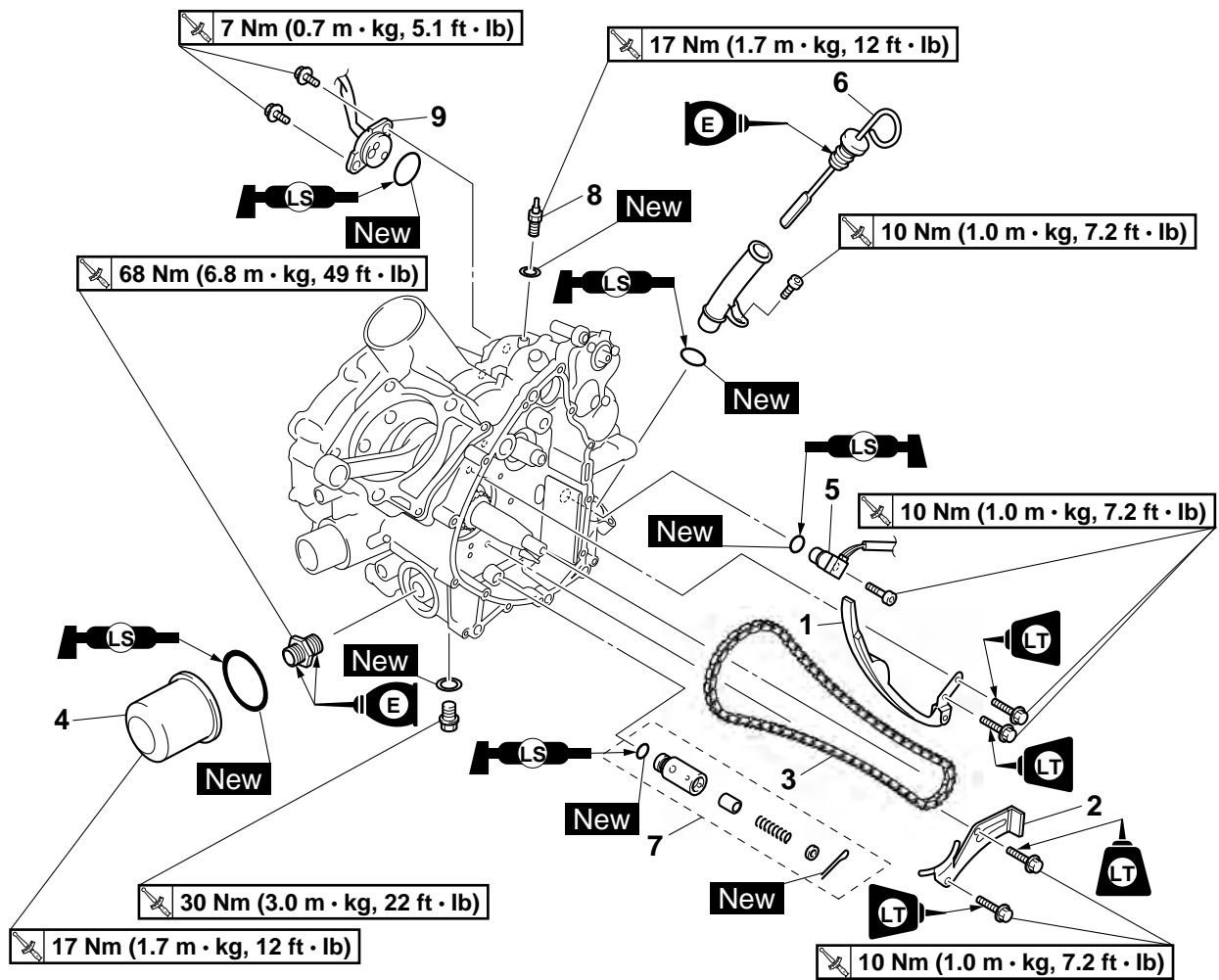

Order	Job/Parts to remove	Q'ty	Remarks
	Engine		Refer to "ENGINE REMOVAL" on page 5-1.
	Cylinder head		Refer to "CYLINDER HEAD" on page 5-10.
	Cylinder/Piston		Refer to "CYLINDER AND PISTON" on page 5-28.
	AC magneto rotor/Starter wheel gear		Refer to "AC MAGNETO AND STARTER CLUTCH" on page 5-33.
	Balancer driven gear/Oil pump driven gear		Refer to "BALANCER GEARS AND OIL PUMP GEARS" on page 5-43.
	Primary sheave assembly/Secondary sheave assembly		Refer to "PRIMARY AND SECONDARY SHEAVES" on page 5-46.
	Clutch carrier assembly		Refer to "CLUTCH" on page 5-54.
1	Timing chain guide (intake side)	1	
2	Timing chain guide (lower)	1	
3	Timing chain	1	
4	Oil filter cartridge	1	
5	Speed sensor	1	
6	Dipstick	1	

CRANKCASE

Removing the timing chain and oil filter cartridge

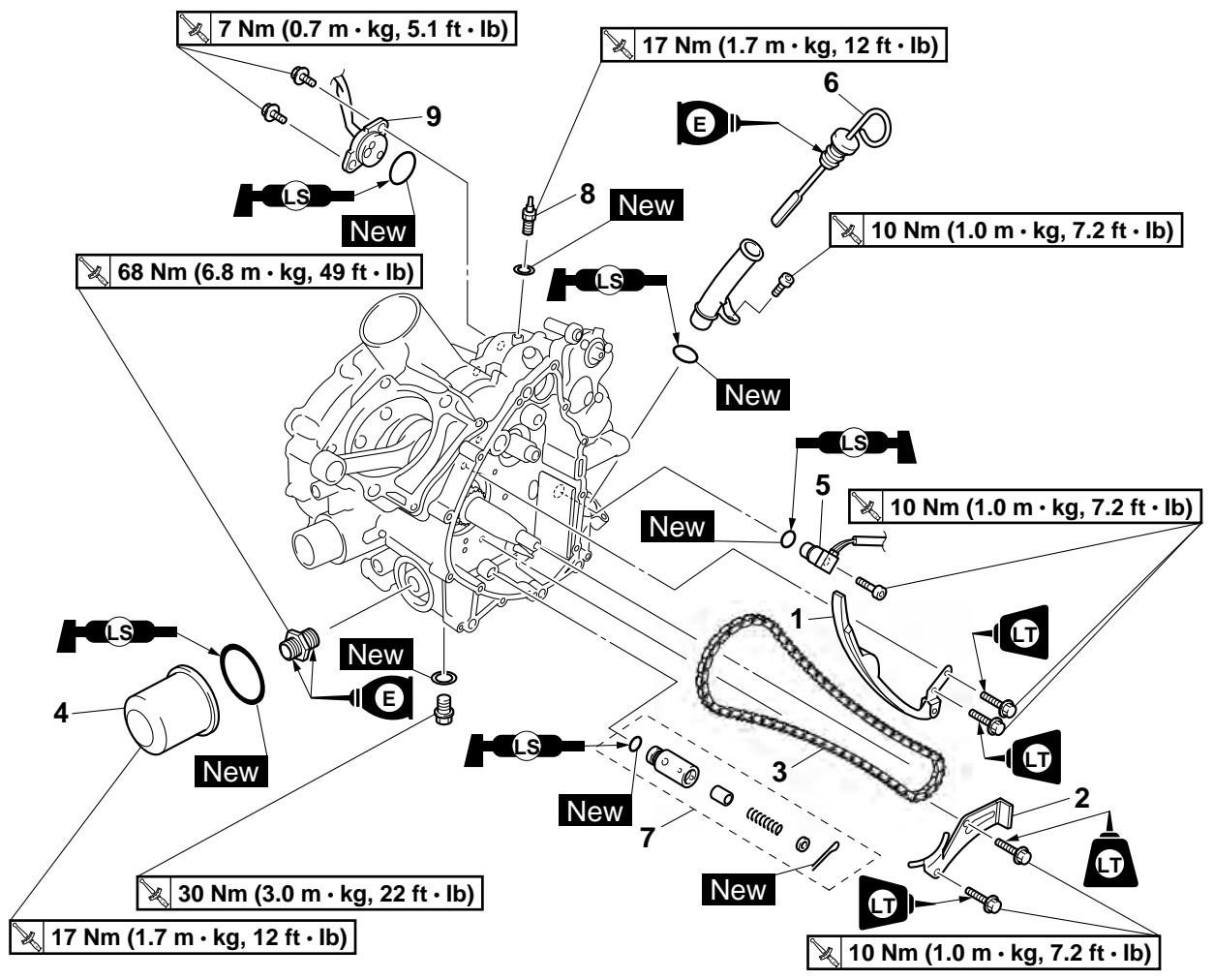

Order	Job/Parts to remove	Q'ty	Remarks
7	Relief valve assembly	1	
8	Reverse switch	1	
9	Gear position switch	1	
			For installation, reverse the removal procedure.

CRANKCASE

Separating the crankcase

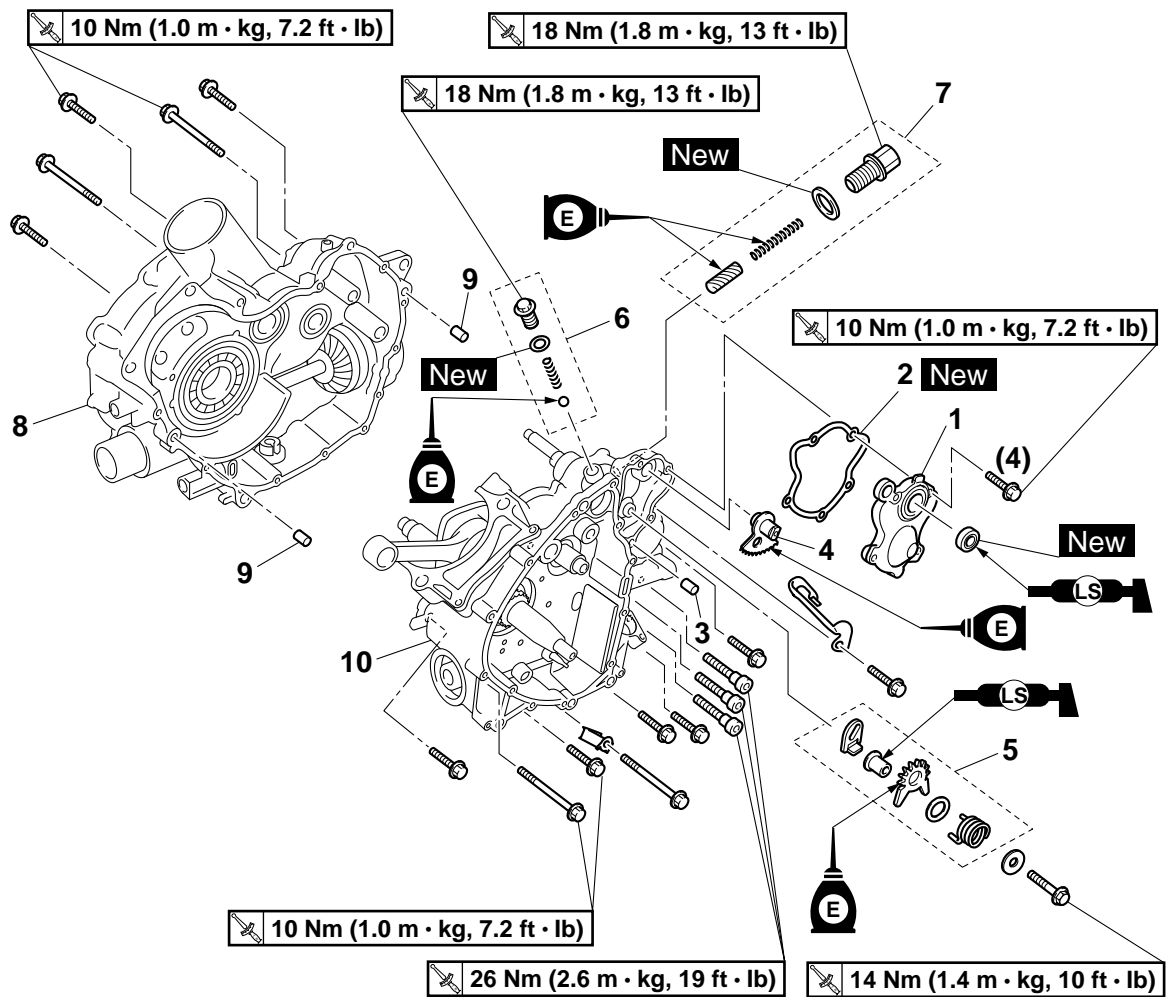

Order	Job/Parts to remove	Q'ty	Remarks
1	Shift lever cover	1	
2	Gasket	1	
3	Dowel pin	1	
4	Shift lever 1	1	
5	Shift lever 2 assembly	1	
6	Shift drum stopper	1	Spring identification color: white
7	Stopper lever stopper	1	Spring identification color: red
8	Right crankcase	1	
9	Dowel pin	2	
10	Left crankcase	1	
			For assembly, reverse the disassembly procedure.

CRANKCASE

Removing the crankcase bearings

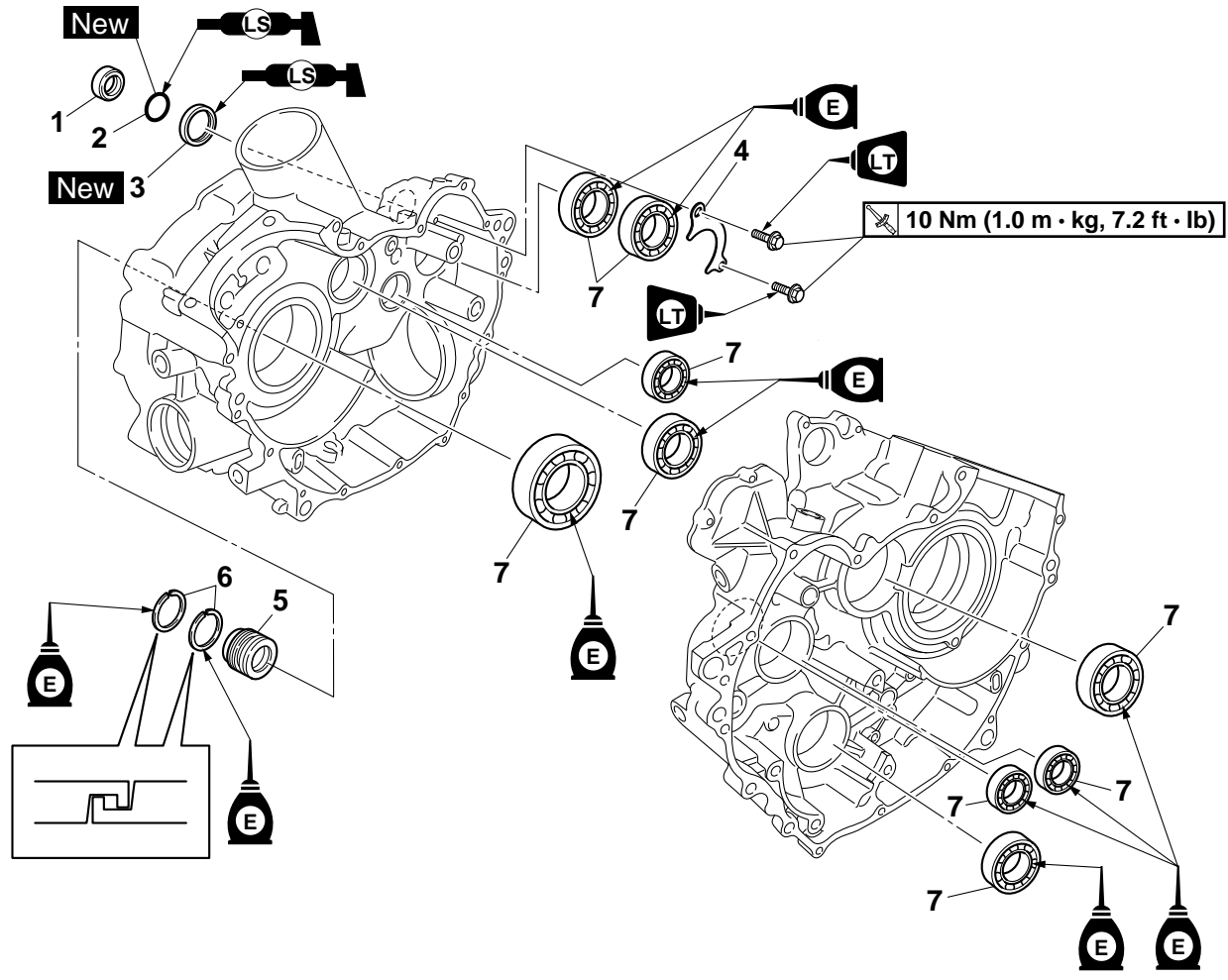

Order	Job/Parts to remove	Q'ty	Remarks
	Crankshaft/Oil pump		Refer to "CRANKSHAFT AND OIL PUMP" on page 5-66.
	Transmission		Refer to "TRANSMISSION" on page 5-71
	Middle drive shaft/Middle driven shaft		Refer to "MIDDLE GEAR" on page 5-78
1	Collar	1	
2	O-ring	1	
3	Oil seal	1	
4	Bearing retainer	1	
5	Spacer	1	
6	Crank seal	2	
7	Bearing	9	
			For installation, reverse the removal procedure.

EAS25560

SEPARATING THE CRANKCASE

- Remove:
 - Crankcase bolts
 - Lead holders

TIP

Loosen each bolt 1/4 of a turn at a time, in stages and in a crisscross pattern. After all of the bolts are fully loosened, remove them.

A

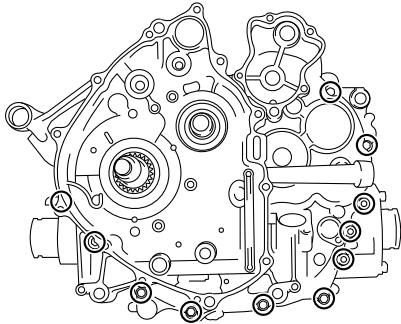

B

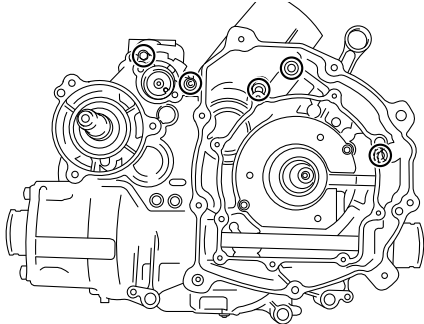

- A. Left crankcase
B. Right crankcase

- Remove:
 - Right crankcase
 - Dowel pins

ECA13900

NOTICE

Tap on one side of the crankcase with a soft-face hammer. Tap only on reinforced portions of the crankcase, not on the crankcase mating surfaces. Work slowly and carefully and make sure the crankcase halves separate evenly.

EAS24180

CHECKING THE TIMING CHAIN AND TIMING CHAIN GUIDE

- Check:
 - Timing chain
Damage/stiffness → Replace the timing chain and camshaft sprocket as a set.

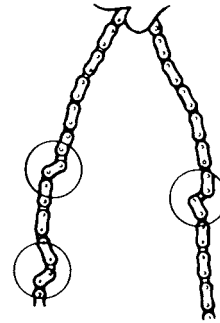

- Check:
 - Timing chain guide (intake side)
Damage/wear → Replace.

EAS28P1050

CHECKING THE RELIEF VALVE

- Check:
 - Spring seat "1"
 - Spring "2"
 - Relief valve body "3"
 - Relief valve "4"
 Damage/wear → Replace the defective part(s).

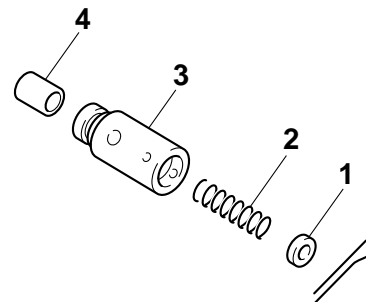

EAS28P1051

CHECKING THE BEARINGS

- Check:
 - Bearings
Clean and lubricate, then rotate the inner race with a finger.
Roughness → Replace.

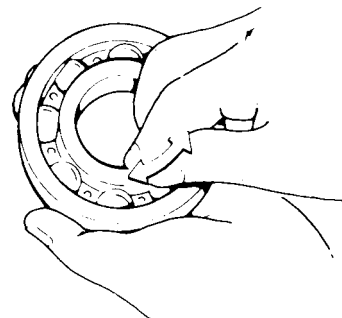

CRANKCASE

EAS25580

CHECKING THE CRANKCASE

1. Thoroughly wash the crankcase halves in a mild solvent.
2. Thoroughly clean all the gasket surfaces and crankcase mating surfaces.
3. Check:
 - Crankcase
Cracks/damage → Replace.
 - Oil delivery passages
Obstruction → Blow out with compressed air.

EAS25700

ASSEMBLING THE CRANKCASE

1. Install:

- Oil seal "1" **New**



Installed depth "a"
1.0–1.5 mm (0.04–0.06 in)

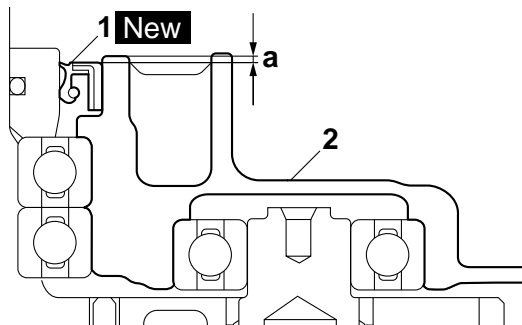

2. Crankcase

2. Thoroughly clean the crankcase mating surfaces.
3. Apply:
 - Sealant "1"
(onto the crankcase mating surfaces)



Yamaha bond No. 1215
90890-85505
(Three Bond No.1215®)

TIP

- Apply two coats of sealant to the area "a" shown in the illustration.
- Do not allow any sealant to come into contact with the oil gallery.

4. Install:

- Dowel pins "2"

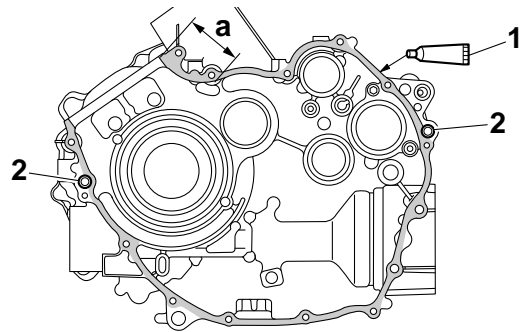

5. Fit the right crankcase onto the left crankcase. Tap lightly on the case with a soft hammer.

ECA28P1034

NOTICE

Before installing and torquing the crankcase holding bolts, be sure to check whether the transmission is functioning properly by manually rotating the shift drum in both directions.

6. Install:
 - Lead holders
 - Crankcase bolts
7. Tighten:
 - Crankcase bolts



Crankcase bolt "1"
26 Nm (2.6 m·kg, 19 ft·lb)
Crankcase bolt "2", "3"
10 Nm (1.0 m·kg, 7.2 ft·lb)

M8 × 40 mm "1"
M6 × 60 mm "2"
M6 × 30 mm "3"

TIP

Tighten the bolts in stages, using a crisscross pattern.

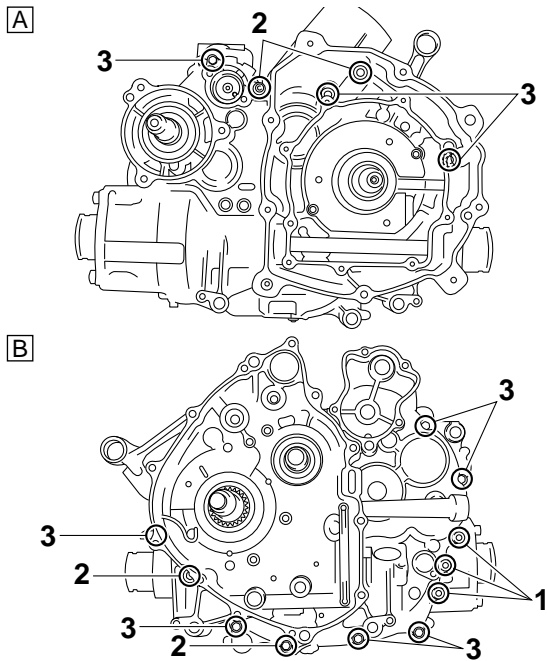

- A. Right crankcase
- B. Left crankcase

8. Apply:
 - 4-stroke engine oil
(to the crankshaft pin, bearings and oil delivery hole)
9. Check:
 - Crankshaft and transmission operation
Rough operation → Repair.

EAS28P1052

INSTALLING THE SHIFT LEVER

1. Install:
 - Shift lever 2 assembly "1"
 - Shift lever 1 "2"

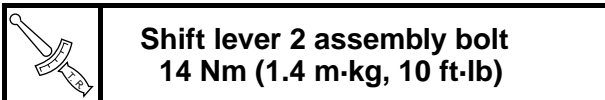

TIP

When installing the shift lever 1, align the alignment mark "a" on the shift lever 1 with the punch marks "b" on the shift lever 2.

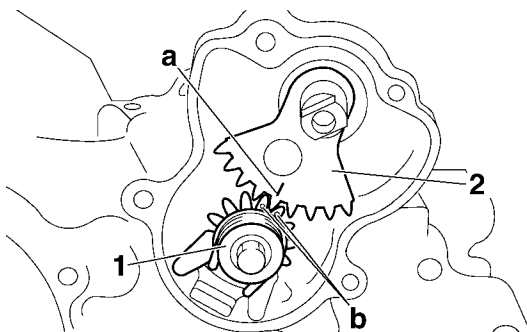

CRANKSHAFT AND OIL PUMP

EAS28P1053

CRANKSHAFT AND OIL PUMP

Removing the crankshaft and oil pump

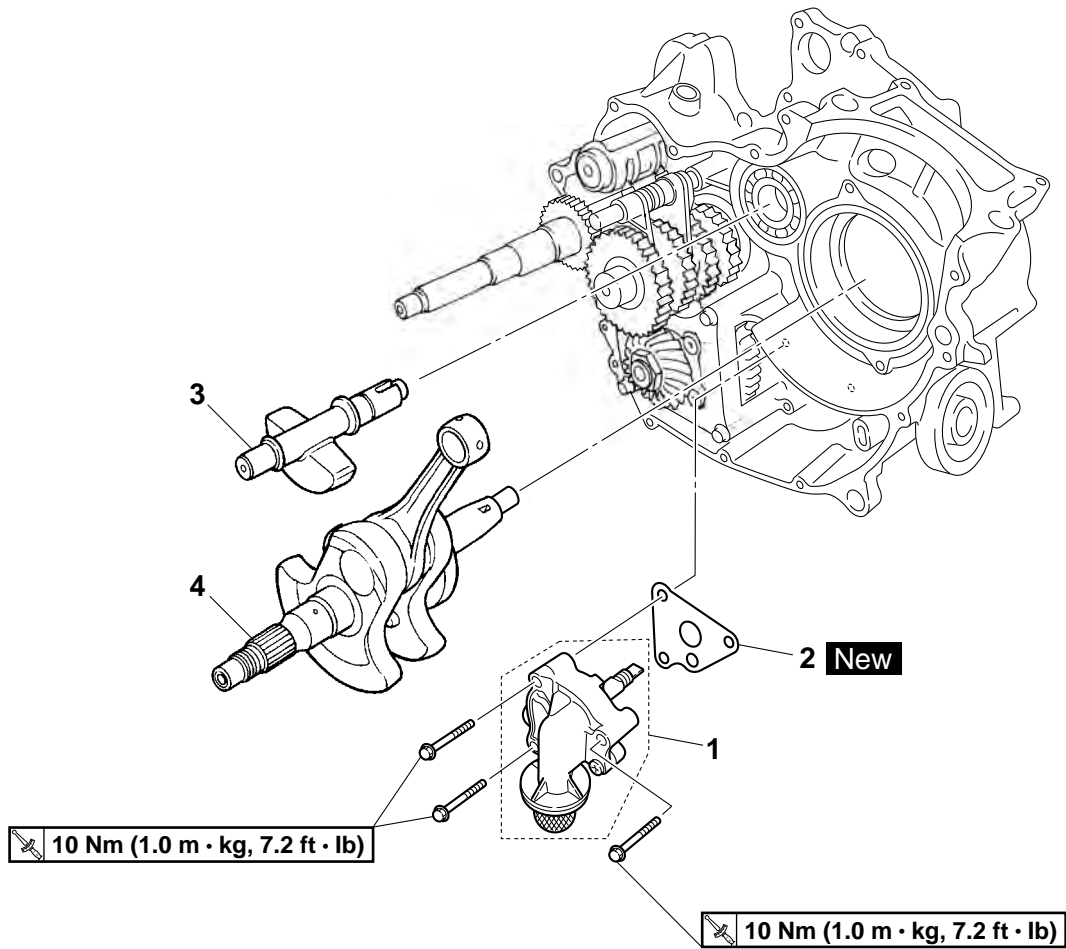

Order	Job/Parts to remove	Q'ty	Remarks
	Crankcase		Separate. Refer to "CRANKCASE" on page 5-59.
1	Oil pump	1	
2	Gasket	1	
3	Balancer	1	
4	Crankshaft	1	
			For installation, reverse the removal procedure.

CRANKSHAFT AND OIL PUMP

Disassembling the oil pump

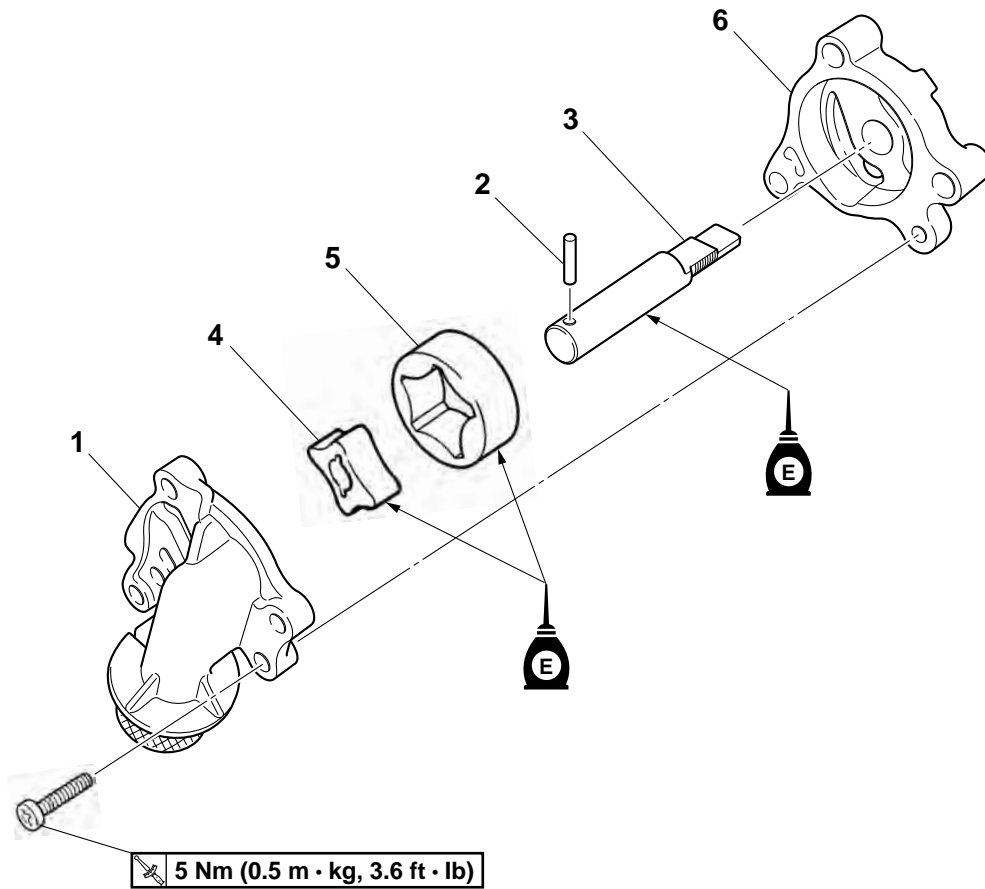

Order	Job/Parts to remove	Q'ty	Remarks
1	Oil pump housing cover	1	
2	Pin	1	
3	Oil pump shaft	1	
4	Inner rotor	1	
5	Outer rotor	1	
6	Oil pump housing	1	
			For assembly, reverse the disassembly procedure.

CRANKSHAFT AND OIL PUMP

EAS28P1054

REMOVING THE CRANKSHAFT

- Remove:
 - Crankshaft "1"

TIP

- Remove the crankshaft with the crankcase separating tool "2".
- Make sure the crankcase separating tool is centered over the crankshaft.

ECA28P1029

NOTICE

- To protect the end of the crankshaft, place an appropriate sized socket between the crankcase separating tool bolt and the crankshaft.
- Do not tap on the crankshaft.



**Crankcase separating tool
90890-01135
Crankcase separator
YU-01135-B**

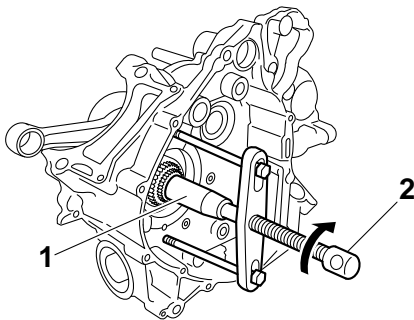

EAS24960

CHECKING THE OIL PUMP

- Check:
 - Oil pump housing
 - Oil pump housing cover
 Cracks/damage/wear → Replace the defective part(s).
- Measure:
 - Inner-rotor-to-outer-rotor-tip clearance "a"
 - Outer-rotor-to-oil-pump-housing clearance "b"
 - Oil-pump-housing-to-inner-rotor-and-outer-rotor clearance "c"
 Out of specification → Replace the oil pump.



**Inner-rotor-to-outer-rotor-tip
clearance**

Less than 0.12 mm (0.0047 in)

Limit

0.20 mm (0.0079 in)

**Outer-rotor-to-oil-pump-housing
clearance**

0.090–0.170 mm (0.0035–0.0067 in)

Limit

0.24 mm (0.0094 in)

**Oil-pump-housing-to-inner-and-
outer-rotor clearance**

0.03–0.10 mm (0.0012–0.0039 in)

Limit

0.17 mm (0.0067 in)

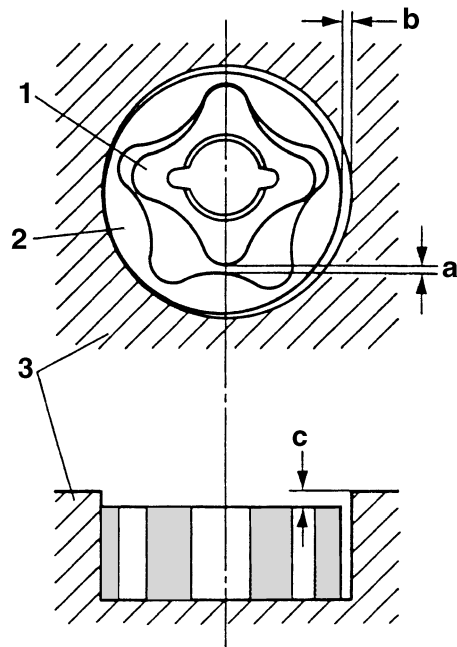

1. Inner rotor
2. Outer rotor
3. Oil pump housing

3. Check:

- Oil pump operation
- Rough movement → Repeat steps (1) and (2) or replace the defective part(s).

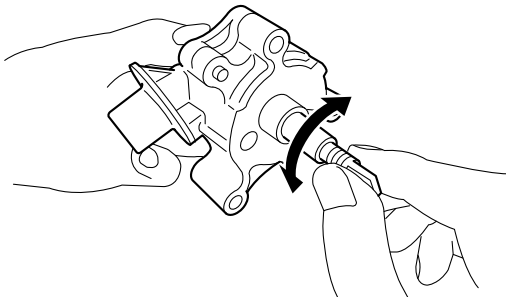

EAS24990

CHECKING THE OIL STRAINER

- Check:
 - Oil strainer
 - Damage → Replace.
 - Contaminants → Clean with solvent.

EAS28P1055

CHECKING THE CRANKSHAFT

- Measure:
 - Crankshaft width A “a”
 - Out of specification → Replace the crankshaft.



Width A
74.92–75.00 mm (2.950–2.953 in)

- Measure:
 - Crankshaft runout C “b”
 - Out of specification → Replace the crankshaft.



Runout limit C
0.030 mm (0.0012 in)

- Measure:
 - Big end side clearance D “c”
 - Out of specification → Replace the crankshaft.



Big end side clearance D
0.350–0.650 mm (0.0138–0.0256 in)

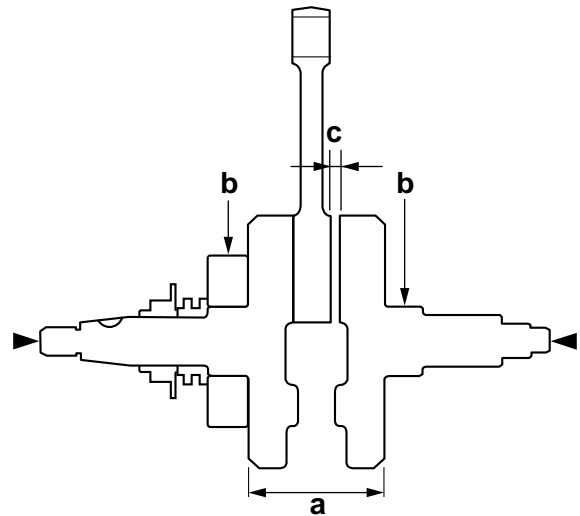

- Check:
 - Crankshaft sprocket
 - Damage/wear → Replace the crankshaft.
 - Bearing
 - Cracks/damage/wear → Replace the crankshaft.
- Check:
 - Crankshaft journal
 - Scratches/wear → Replace the crankshaft.
 - Crankshaft journal oil passage
 - Obstruction → Blow out with compressed air.

EAS25010

ASSEMBLING THE OIL PUMP

- Lubricate:
 - Inner rotor
 - Outer rotor
 - Oil pump shaft
 - (with the recommended lubricant)



Recommended lubricant
Engine oil

- Install:
 - Oil pump housing “1”
 - Outer rotor “2”
 - Inner rotor “3”
 - Oil pump shaft “4”
 - Pin “5”

TIP

To install the oil pump shaft “4”, align the pin “5” with the groove “a” in the inner rotor “3”.

CRANKSHAFT AND OIL PUMP

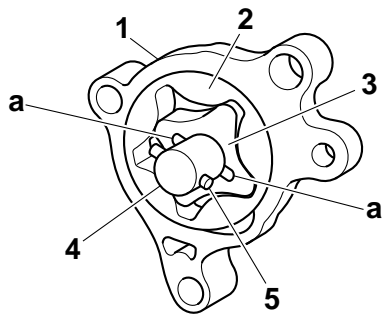

3. Check:

- Oil pump operation
Refer to "CHECKING THE OIL PUMP" on page 5-68.

EAS28P1056

INSTALLING THE CRANKSHAFT

1. Install:

- Crankshaft "1"

TIP

Install the crankshaft assembly with the crankshaft installer pot "2", crankshaft installer bolt "3", adapter (M16) "4", spacer (crankshaft installer) "5" and spacer "6".

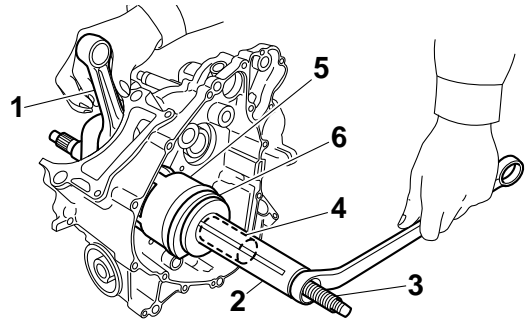

ECA28P1035

NOTICE

Apply engine oil to each bearing to protect the crankshaft against scratches and to make installation easier.

TIP

Hold the connecting rod at top dead center (TDC) with one hand while turning the nut of the crankshaft installer bolt with the other. Turn the crankshaft installer bolt until the crankshaft assembly bottoms against the bearing.



Crankshaft installer pot
90890-01274
Installing pot
YU-90058
Crankshaft installer bolt
90890-01275
Bolt
YU-90060
Adapter (M16)
90890-04130
Adapter #13
YM-04059
Spacer (crankshaft installer)
90890-04081
Pot spacer
YM-91044
Spacer
90890-01309
Pot spacer
YU-90059

EAS26241

TRANSMISSION

Removing the transmission, shift drum and shift forks

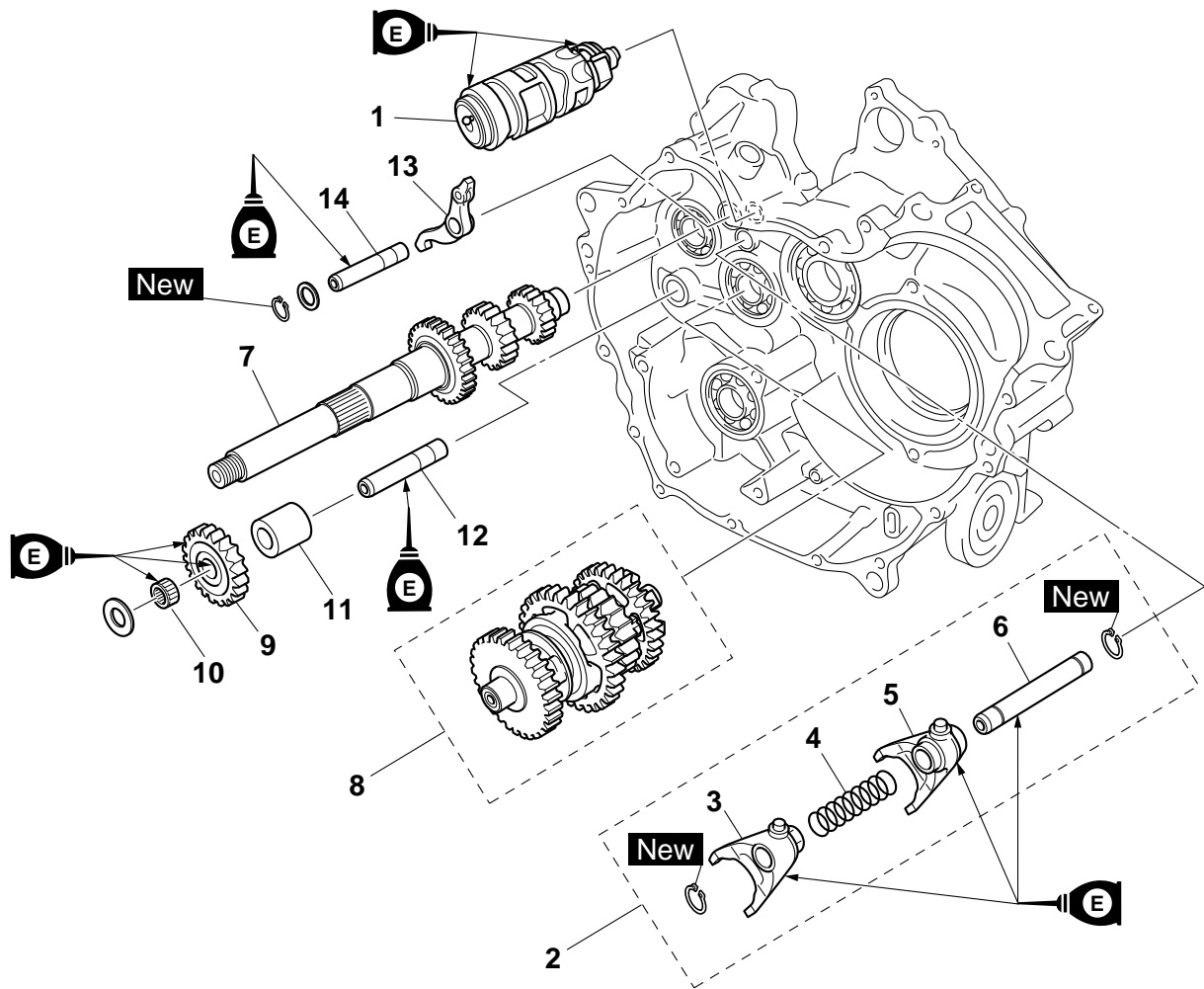

Order	Job/Parts to remove	Q'ty	Remarks
	Crankcase		Separate. Refer to "CRANKCASE" on page 5-59
	Middle driven gear		Refer to "MIDDLE GEAR" on page 5-78
1	Shift drum	1	
2	Shift fork assembly	1	
3	Shift fork "R"	1	
4	Spring	1	
5	Shift fork "L"	1	
6	Shift fork guide bar	1	
7	Secondary shaft	1	
8	Drive axle assembly	1	
9	Reverse idle gear	1	
10	Bearing	1	
11	Collar	1	
12	Reverse idle gear shaft	1	
13	Stopper lever	1	

TRANSMISSION

Removing the transmission, shift drum and shift forks

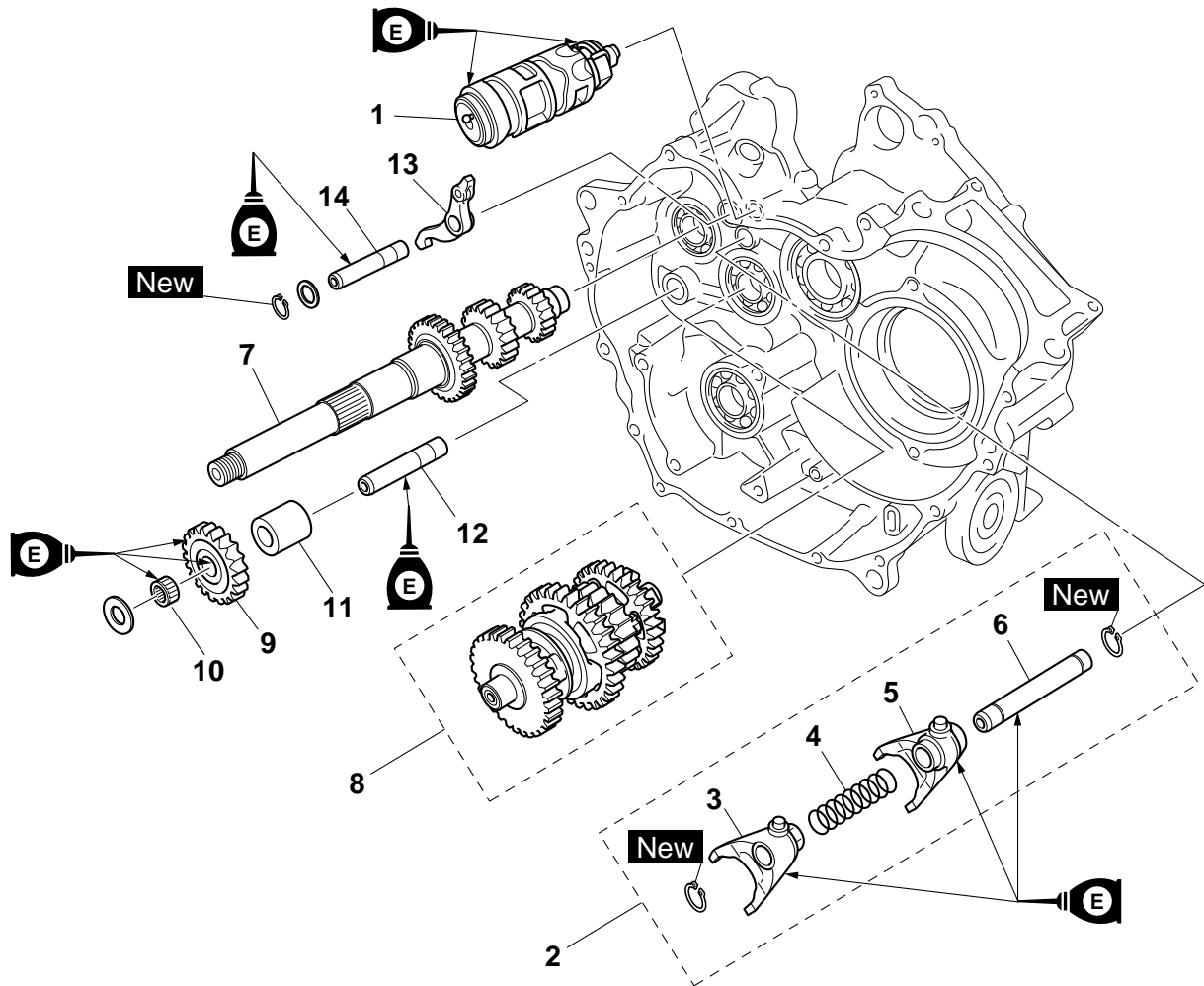

Order	Job/Parts to remove	Q'ty	Remarks
14	Stopper lever shaft	1	
			For installation, reverse the removal procedure.

TRANSMISSION

Disassembling the drive axle assembly

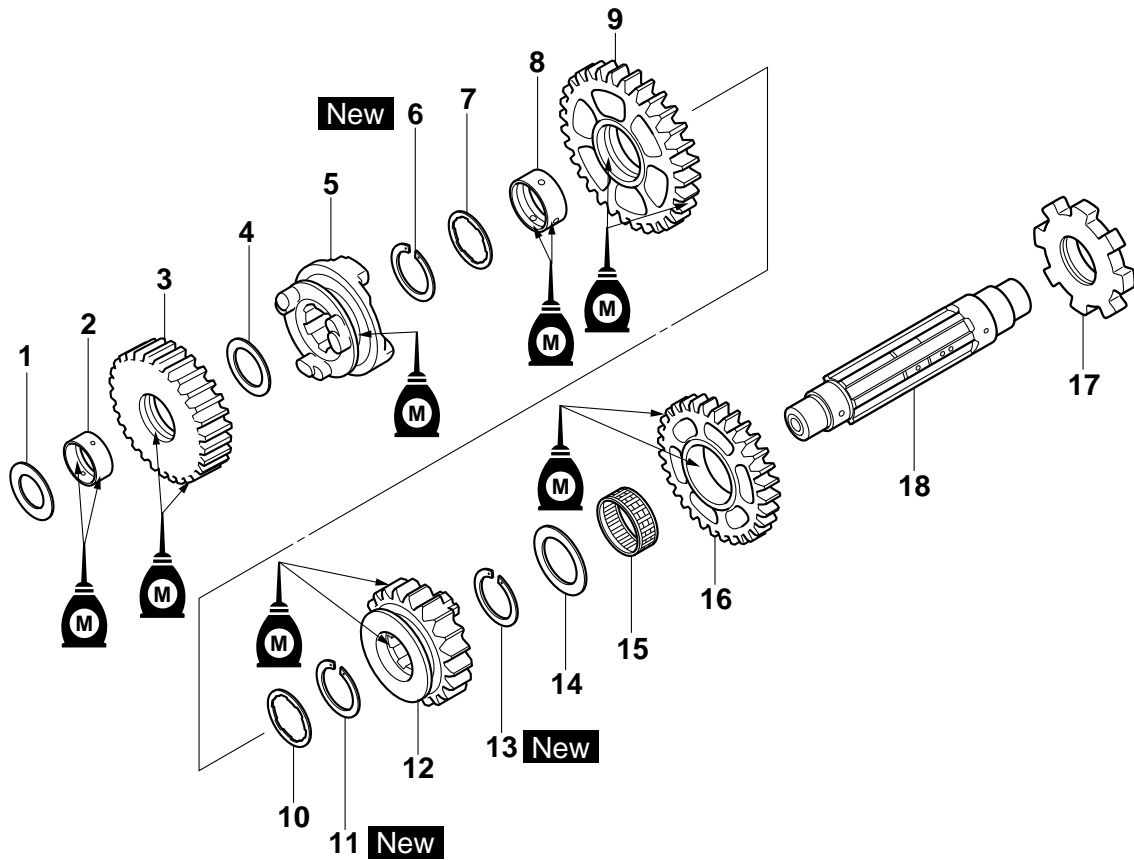

Order	Job/Parts to remove	Q'ty	Remarks
1	Washer	1	
2	Collar	1	
3	High wheel gear	1	
4	Washer	1	
5	Clutch dog	1	
6	Circlip	1	
7	Washer	1	
8	Collar	1	
9	Low wheel gear	1	
10	Washer	1	
11	Circlip	1	
12	Middle drive gear	1	
13	Circlip	1	
14	Washer	1	
15	Bearing	1	
16	Reverse wheel gear	1	
17	Stopper wheel	1	

TRANSMISSION

Disassembling the drive axle assembly

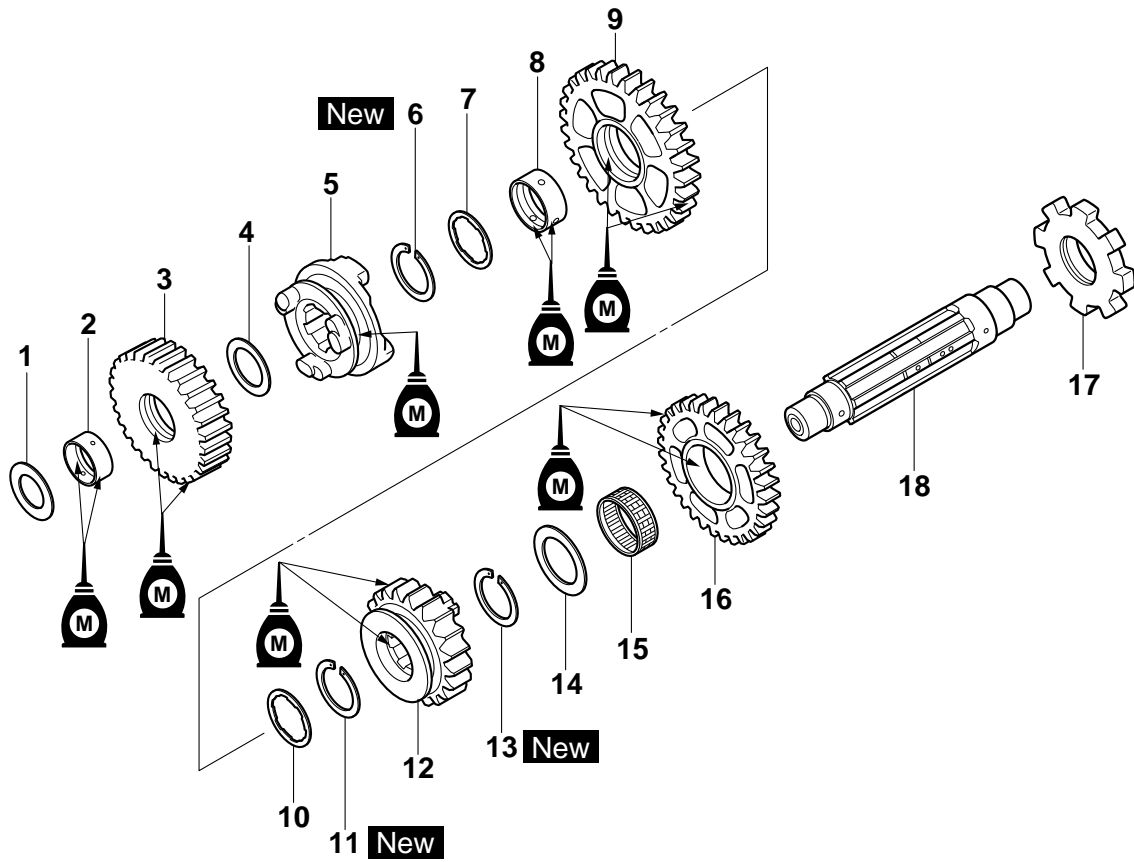

Order	Job/Parts to remove	Q'ty	Remarks
18	Drive axle	1	
			For assembly, reverse the disassembly procedure.

EAS26250

REMOVING THE TRANSMISSION

1. Remove:
 - Shift drum "1"
 - Shift fork assembly "2"

- a. Pull out the guide bar from the left crankcase.
- b. Push down on the drive shaft, and then slide the shift fork assembly to remove the shift fork cam followers.
- c. Remove the shift drum.
- d. Remove the shift fork assembly.

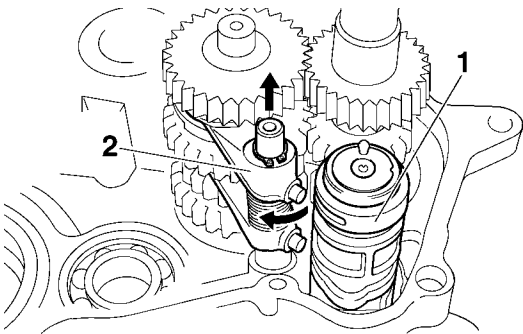

EAS26260

CHECKING THE SHIFT FORKS

The following procedure applies to all of the shift forks.

1. Check:
 - Shift fork cam follower "1"
 - Shift fork pawl "2"
 Bends/damage/scoring/wear → Replace the shift fork.

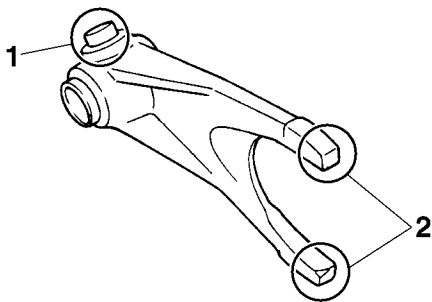

2. Check:
 - Shift fork guide bar
 Roll the shift fork guide bar on a flat surface.
 Bends → Replace.

EWA12840

⚠ WARNING

Do not attempt to straighten a bent shift fork guide bar.

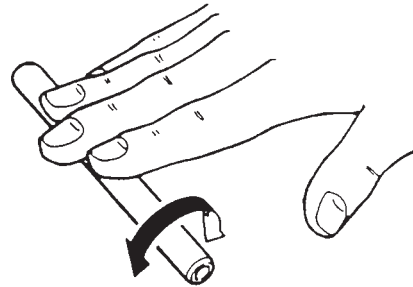

319-010

3. Check:
 - Shift fork movement (along the shift fork guide bar)
 Rough movement → Replace the shift forks and shift fork guide bar as a set.

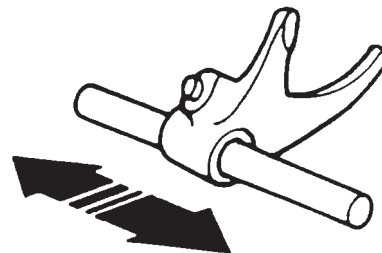

319-011

4. Check:
 - Spring
 Cracks/damage → Replace.

EAS28P1057

CHECKING THE SHIFT DRUM

1. Check:
 - Shift drum grooves
 Damage/scratches/wear → Replace the shift drum.

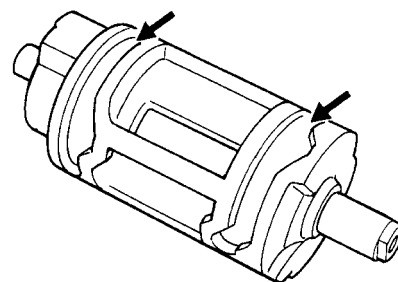

EAS26300

CHECKING THE TRANSMISSION

1. Measure:
 - Drive axle runout (with a centering device and dial gauge "1")
 Out of specification → Replace the drive axle.



**Drive axle runout limit
0.06 mm (0.0024 in)**

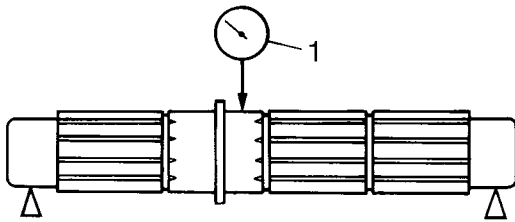

2. Check:

- Transmission gears
Blue discoloration/pitting/wear → Replace the defective gear(s).
- Transmission gear dogs
Cracks/damage/rounded edges → Replace the defective gear(s).

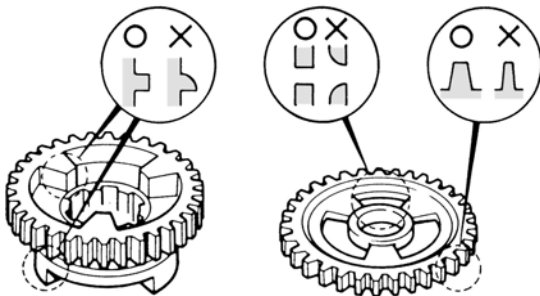

3. Check:

- Transmission gear engagement
(each pinion gear to its respective wheel gear)
Incorrect → Reassemble the transmission axle assemblies.

4. Check:

- Transmission gear movement
Rough movement → Replace the defective part(s).

5. Check:

- Circlips
Bends/damage/looseness → Replace.

EAS28P1058

CHECKING THE SECONDARY SHAFT

1. Check:

- Gear teeth
Blue discoloration/pitting/wear → Replace.

EAS28P1059

CHECKING THE STOPPER LEVER AND STOPPER WHEEL

1. Check:

- Stopper lever pawl "1"
Bends/damage/wear → Replace the stopper lever and stopper wheel as a set.

- Stopper wheel "2"
Damage/wear → Replace the stopper wheel and stopper lever as a set.
- Stopper lever shaft "3"
Bends/damage/wear → Replace.

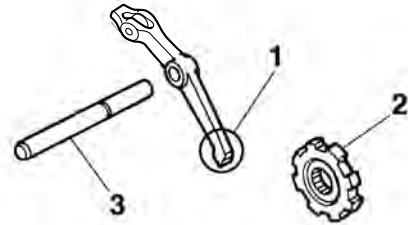

EAS28P1060

ASSEMBLING THE SHIFT FORK ASSEMBLY

1. Install:

- Shift fork guide bar "1"
- Shift fork "L" "2"
- Spring "3"
- Shift fork "R" "4"
- Circlip "5" **New**

TIP

Install the shift forks with "28P" mark "a" and "3B4" mark "b" facing each other.

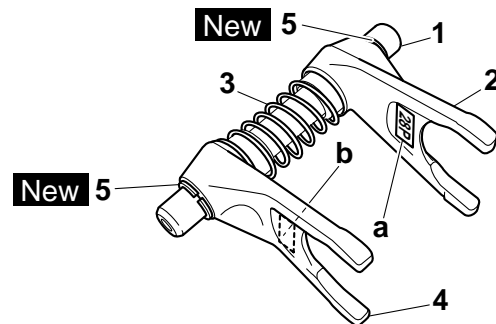

EAS28P1061

INSTALLING THE SHIFT FORKS AND SHIFT DRUM

1. Install:

- Stopper lever shaft
- Stopper lever
- Reverse idle gear "1"
- Drive axle assembly "2"
- Secondary shaft "3"
- Shift fork assembly "4"
- Shift drum "5"

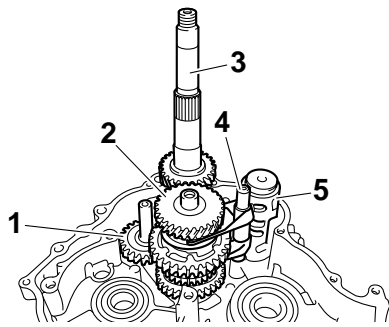

TIP

Install the shift forks "6" with the "L" mark "a" and "R" mark "b" facing towards the left and right sides of the crankcase respectively.

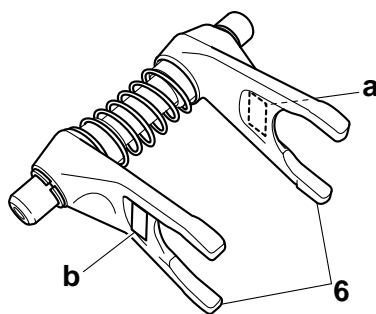

2. Check:

- Shift operation
- Rough operation → Repair.

TIP

- Oil each gear and bearing thoroughly.
 - Before assembling the crankcase, make sure that the transmission is in neutral and that the gears turn freely.
-

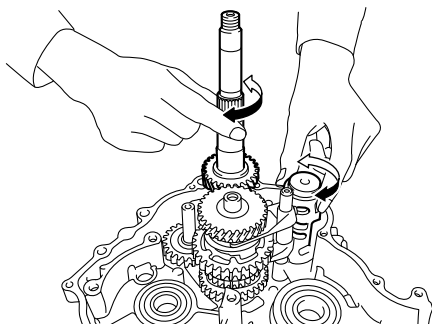

EAS25710

MIDDLE GEAR

Removing the middle drive shaft

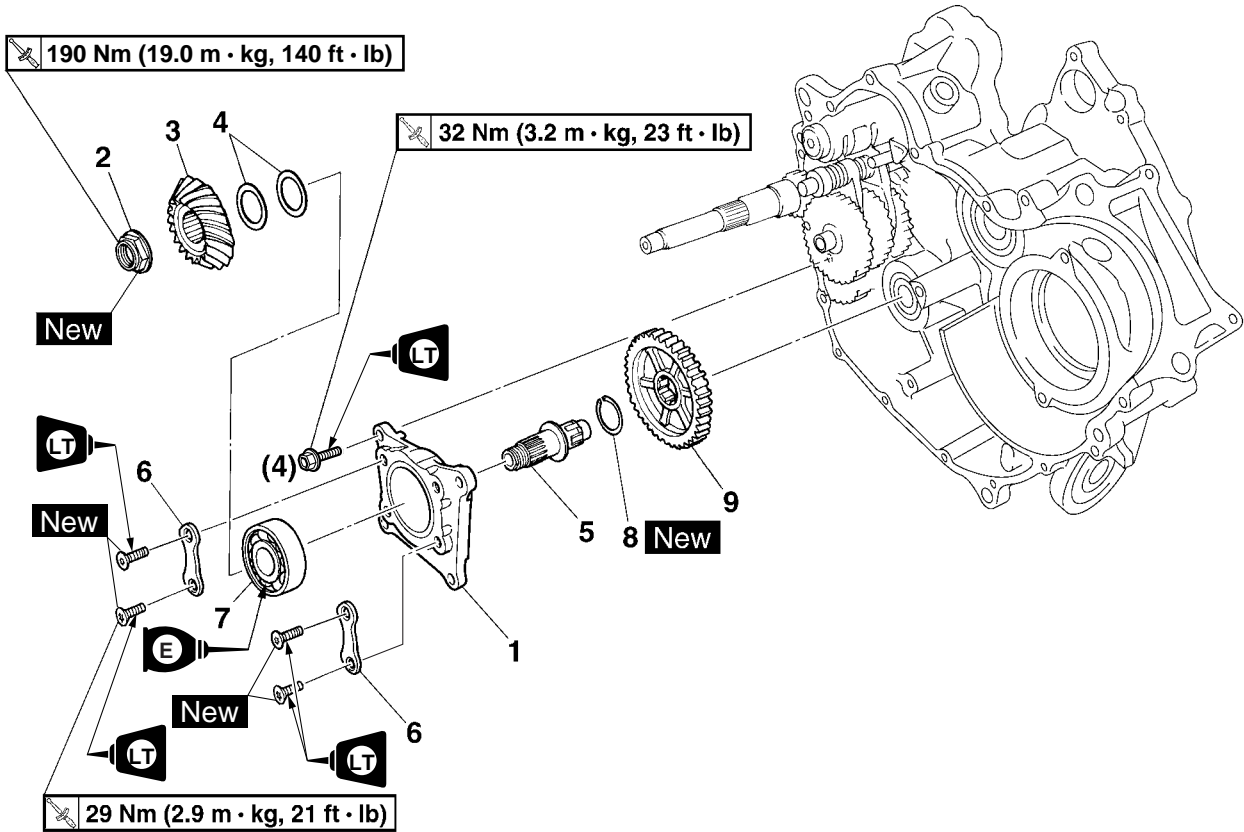

Order	Job/Parts to remove	Q'ty	Remarks
	Crankcase		Separate. Refer to "CRANKCASE" on page 5-59.
1	Bearing housing	1	
2	Middle drive pinion gear nut	1	
3	Middle drive pinion gear	1	
4	Middle drive pinion gear shim		Refer to "ALIGNING THE MIDDLE GEAR" on page 5-86.
5	Middle drive shaft	1	
6	Bearing retainer	2	
7	Bearing	1	
8	Circlip	1	
9	Middle driven gear	1	
			For installation, reverse the removal procedure.

Removing the middle driven shaft

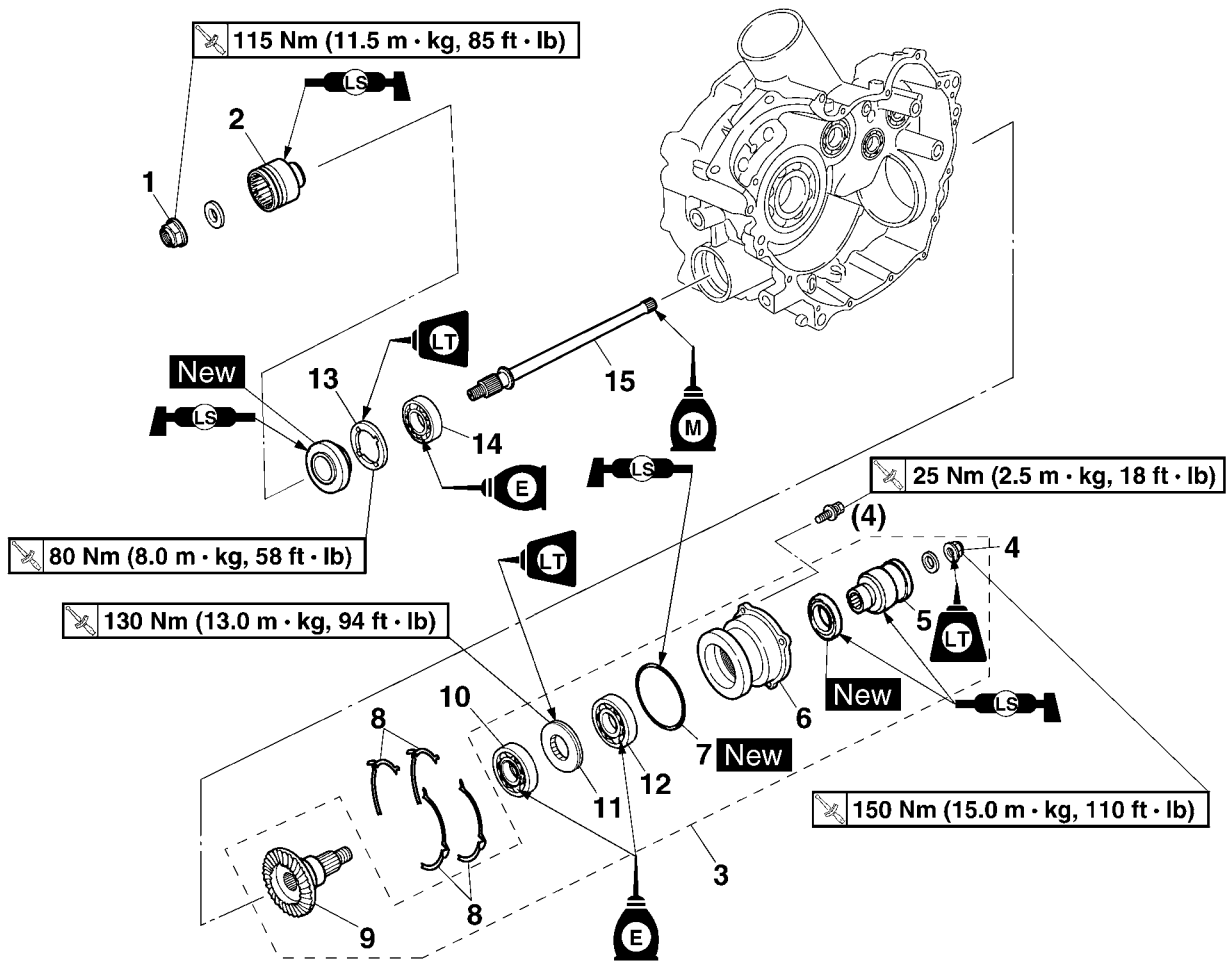

Order	Job/Parts to remove	Q'ty	Remarks
	Crankcase		Separate. Refer to "CRANKCASE" on page 5-59.
1	Front drive shaft yoke nut (middle gear side)	1	
2	Front drive shaft yoke (middle gear side)	1	
3	Middle driven pinion gear assembly	1	
4	Rear drive shaft yoke nut (middle gear side)	1	
5	Rear drive shaft yoke (middle gear side)	1	
6	Bearing housing	1	
7	O-ring	1	
8	Middle driven pinion gear shim		Refer to "ALIGNING THE MIDDLE GEAR" on page 5-86.
9	Middle driven pinion gear	1	
10	Bearing	1	
11	Middle driven pinion gear bearing retainer	1	
12	Bearing	1	
13	Middle driven shaft bearing retainer	1	
14	Bearing	1	

MIDDLE GEAR

Removing the middle driven shaft

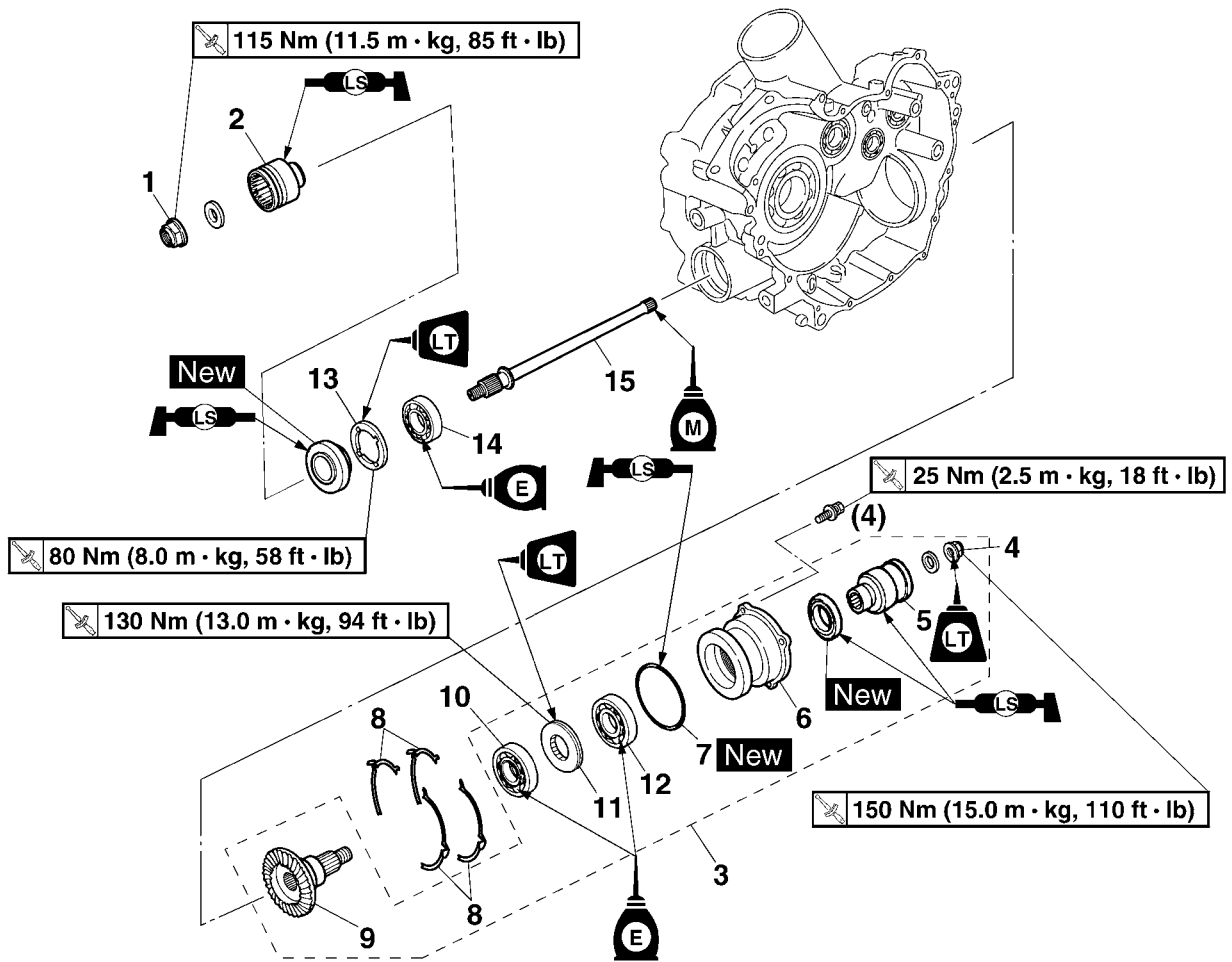

Order	Job/Parts to remove	Q'ty	Remarks
15	Middle driven shaft	1	
			For installation, reverse the removal procedure.

EAS28P1062

REMOVING THE MIDDLE DRIVE SHAFT

1. Straighten:
 - Punched portion of the middle drive pinion gear nut
2. Loosen:
 - Middle drive pinion gear nut "1"

TIP

Wrap the middle drive shaft in a folded rag, and then secure it in a vise.

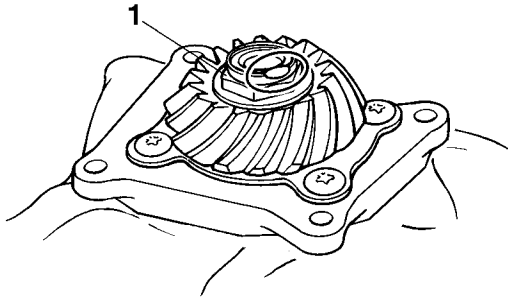

3. Remove:
 - Middle drive pinion gear nut
 - Middle drive pinion gear
 - Shim(s)
4. Remove:
 - Middle driven gear "1"
 - Circlip
 - Middle drive shaft "2"

TIP

Press the middle drive shaft end and remove the middle driven gear.

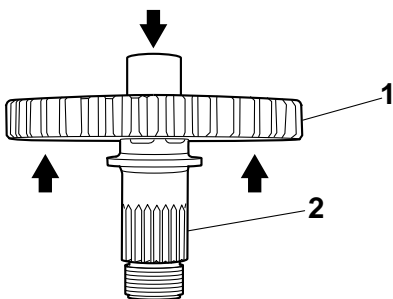

EAS28P1063

REMOVING THE MIDDLE DRIVEN SHAFT

1. Remove:
 - Front drive shaft yoke nut (middle gear side) "1"
 - Washer
 - Front drive shaft yoke (middle gear side) "2"

TIP

Use the coupling gear/middle shaft tool "3" to hold the front drive shaft coupling sleeve.



Coupling gear/middle shaft tool
90890-01229
Gear holder
YM-01229

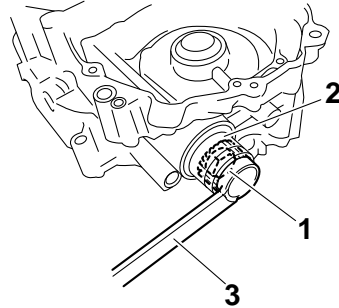

2. Remove:
 - Rear drive shaft yoke nut (middle gear side) "1"
 - Washer
 - Rear drive shaft yoke (middle gear side) "2"

TIP

Use the coupling gear/middle shaft tool "3" to hold the rear drive shaft coupling sleeve.



Coupling gear/middle shaft tool
90890-01229
Gear holder
YM-01229

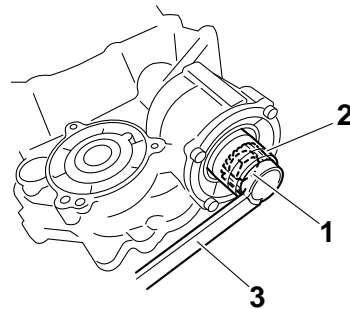

3. Remove:
 - Bearing housing assembly "1"

- a. Clean the surface of the bearing housing assembly.
- b. Place the bearing housing assembly onto a hydraulic press.

ECA28P1036

NOTICE

- **Never directly press the middle driven pinion gear end with a hydraulic press, this will result in damage to the middle driven pinion gear thread.**

- Install a suitable socket “2” on the middle driven pinion gear end to protect the thread from damage.

- c. Press the middle driven pinion gear end and remove the bearing housing.

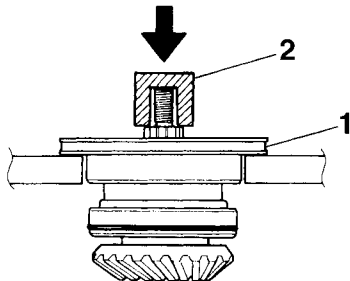

4. Remove:
- Middle driven pinion gear bearing retainer
 - Bearing



- a. Wrap the bearing housing in a folded rag “1”, and then secure the bearing housing edge in a vise.
b. Attach the bearing retainer wrench “2”.



Bearing retainer wrench
90890-04128
Middle gear bearing retainer
YM-04128

ECA28P1037

NOTICE

The middle driven pinion gear bearing retainer has left-handed threads. To loosen the retainer, turn it clockwise.

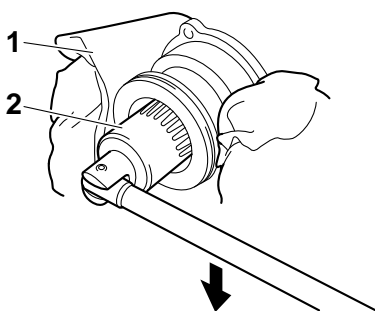

- c. Remove the bearing retainer and bearing.



5. Remove:
- Oil seal “1”
 - Middle driven shaft bearing retainer “2”

TIP

Attach the ring nut wrench “3”.



Ring nut wrench
90890-01430
YM-38404

ECA28P1038

NOTICE

The middle driven shaft bearing retainer has left-handed threads. To loosen the retainer turn it clockwise.

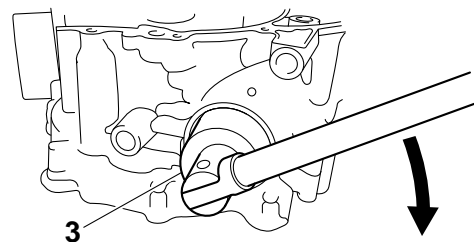
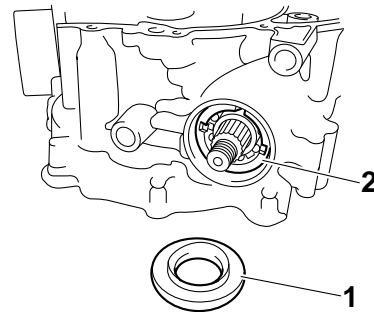

6. Remove:
- Middle driven shaft “1” (with bearing)

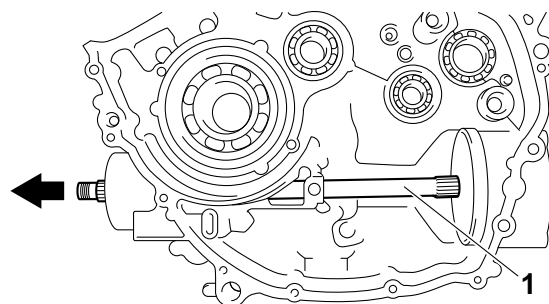

EAS28P1064

CHECKING THE PINION GEARS

1. Check:
 - Drive pinion gear teeth
 - Driven pinion gear teeth
 Pitting/galling/wear → Replace.
2. Check:
 - O-ring
 Damage → Replace.

- Bearings
Pitting/damage → Replace.

EAS28P1065

INSTALLING THE BEARING AND OIL SEALS

1. Install:

- Bearing “1”
- Oil seal “2” **New**
- Oil seal “3” **New**



Installed depth of bearing “a”
0.9–1.4 mm (0.035–0.055 in)
Installed depth of oil seal “b”
1.0–1.5 mm (0.039–0.059 in)
Installed depth of oil seal “c”
1.0–1.5 mm (0.039–0.059 in)

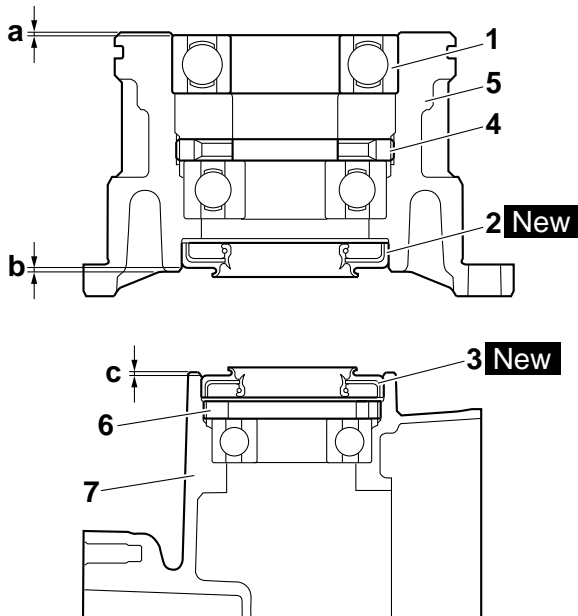

4. Middle drive pinion gear bearing retainer
5. Bearing housing
6. Middle driven shaft bearing retainer
7. Crankcase

EAS28P1066

INSTALLING THE MIDDLE DRIVEN SHAFT

1. Install:

- Middle driven shaft bearing retainer “1”



**Middle driven shaft bearing re-
tainer**
80 Nm (8.0 m·kg, 58 ft·lb)
LOCTITE®

TIP

Attach the ring nut wrench “2”.



Ring nut wrench
90890-01430
YM-38404

ECA28P1039

NOTICE

The middle driven shaft bearing retainer has left-handed threads. To tighten the retainer turn it counterclockwise.

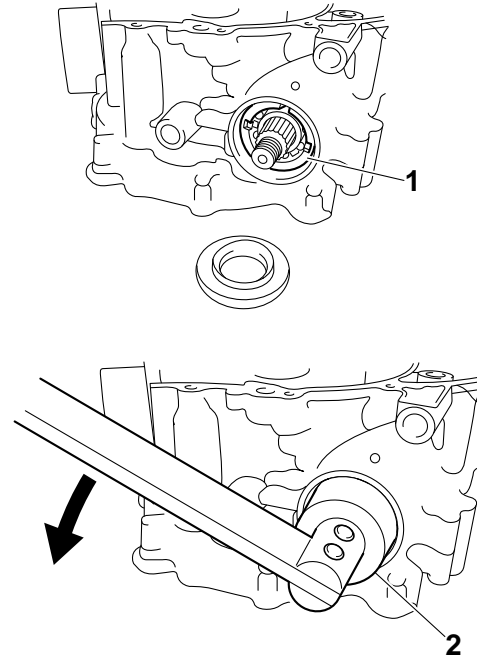

2. Install:

- Middle driven pinion gear bearing retainer “1”

- Wrap the bearing housing in a folded rag, and then secure the bearing housing edge in a vise.
- Attach the bearing retainer wrench “2”.



Bearing retainer wrench
90890-04128
Middle gear bearing retainer
YM-04128

- Tighten the bearing retainer.



Bearing retainer
130 Nm (13.0 m·kg, 94 ft·lb)
LOCTITE®

ECA28P1040

NOTICE

The middle driven pinion gear bearing retainer has left-handed threads. To tighten the retainer turn it counterclockwise.

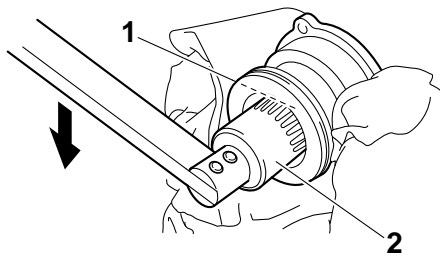

3. Install:
- Middle driven pinion gear shim(s) "1"
 - Bearing housing

TIP

Install the shim(s) so that the tabs are positioned as shown in the illustration.

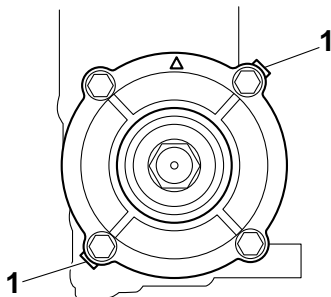

4. Install:
- Rear drive shaft yoke (middle gear side) "1"
 - Washer
 - Rear drive shaft yoke nut (middle gear side) "2"



Rear drive shaft yoke nut (middle gear side)
150 Nm (15.0 m·kg, 110 ft·lb)
LOCTITE®

TIP

Use the coupling gear/middle shaft tool "3" to hold the coupling yoke.



Coupling gear/middle shaft tool
90890-01229
Gear holder
YM-01229

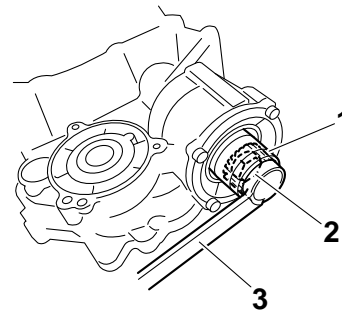

5. Install:
- Front drive shaft yoke (middle gear side) "1"
 - Washer
 - Front drive shaft yoke nut (middle gear side) "2"



Front drive shaft yoke nut (middle gear side)
115 Nm (11.5 m·kg, 85 ft·lb)

TIP

Use the coupling gear/middle shaft tool "3" to hold the coupling yoke.

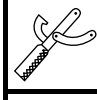

Coupling gear/middle shaft tool
90890-01229
Gear holder
YM-01229

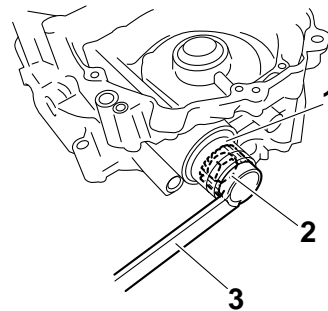

EAS28P1067

INSTALLING THE MIDDLE DRIVE SHAFT

1. Install:
- Circlip
 - Middle driven gear "1" (to the middle drive shaft "2")



Installed depth of middle driven gear "a"
24.7–24.9 mm (0.97–0.98 in)

EAS25890

MEASURING THE MIDDLE GEAR BACKLASH

1. Measure:

- Middle gear backlash

Out of specification → Refer to “ALIGNING THE MIDDLE GEAR” on page 5-86.

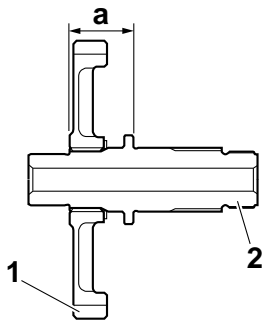

2. Tighten:

- Bearing retainer bolts “1” **New**
- Middle drive pinion gear nut “2” **New**

	<p>Bearing retainer bolt 29 Nm (2.9 m·kg, 21 ft·lb) LOCTITE®</p> <p>Middle drive pinion gear nut 190 Nm (19.0 m·kg, 140 ft·lb)</p>
---	--

TIP _____

Wrap the middle drive shaft in a folded rag, and then secure it in a vise.

3. Lock the threads with a drift punch.

TIP _____

Stake the bearing retainer bolts at the cutouts “a” in the bearing retainers “3”.

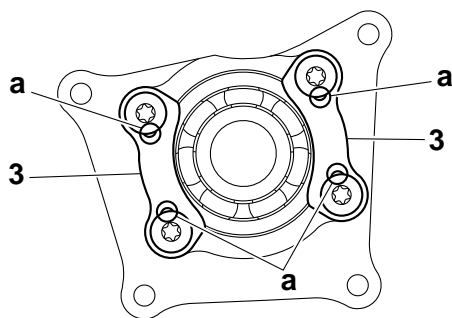
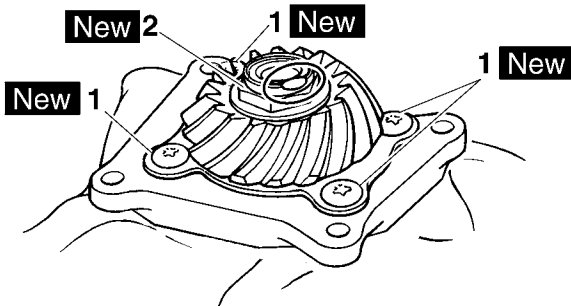

Middle gear backlash
0.10–0.30 mm (0.004–0.012 in)

a. Temporarily install the left crankcase.

b. Wrap a rag “1” around a screwdriver “2”, and then insert it into the installation hole “a” of the left crankcase speed sensor to hold the middle driven gear.

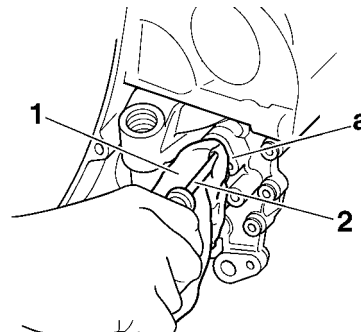

c. Attach the final gear backlash band “3” and dial gauge “4”.



Final gear backlash band
90890-01511
Middle drive gear lash tool
YM-01230

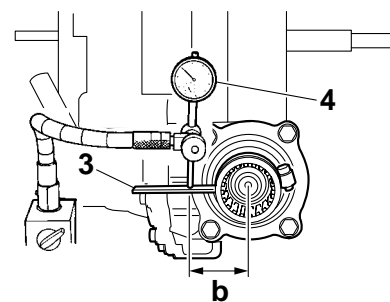

b. 45 mm (1.8 in)

d. Measure the gear lash while rotating the middle driven shaft back and forth.

TIP _____

Measure the gear lash at 4 positions. Rotate the middle driven gear 90° each time.

- e. If the gear lash is incorrect, adjust the gear lash by middle driven pinion gear shims and/or middle drive pinion gear shim(s).

EAS25930

ALIGNING THE MIDDLE GEAR

TIP

Aligning the middle gear is necessary when any of the following parts are replaced:

- Crankcase
- Middle drive gear
- Middle driven gear
- Middle driven shaft bearing housing

1. Select:

- Middle drive pinion gear shim(s) "1"
- Middle driven pinion gear shim(s) "2"

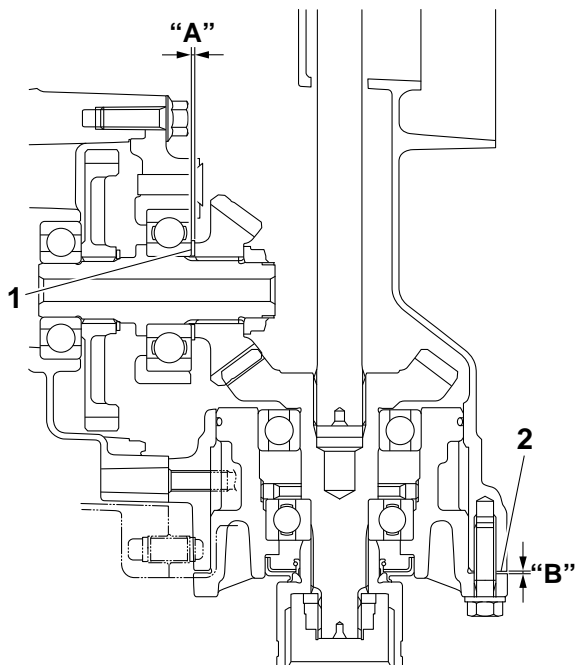
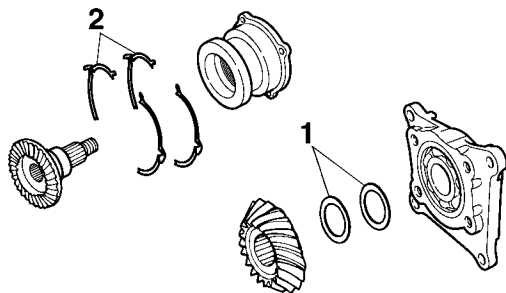

- A. Middle drive pinion gear shim thickness
B. Middle driven pinion gear shim thickness

- a. Position the middle gears with the appropriate shim(s) that has had its respective thickness calculated from information marked on the crankcase, middle driven shaft bearing housing and middle driven pinion gear.
- b. To find middle drive pinion gear shim thickness "A", use the following formula.

Middle drive pinion gear shim thickness
"A" = "e" + "d" - "b" - "c" - "a"

"a" = a numeral (usually a decimal number) on the bearing housing is either added to or subtracted from "0.6"

"b" = 17.0

"c" = 55.0

"d" = a numeral (usually a decimal number) on the right crankcase specifies a thickness of "65.0"

"e" = a numeral (usually a decimal number) on the left crankcase specifies a thickness of "9.0"

Example:

If the bearing housing is marked "-02",
"a" is 0.58

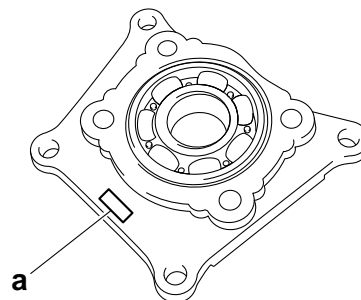

"b" is 17.0

"c" is 55.0

If the right crankcase is marked "64.97",
"d" is 64.97

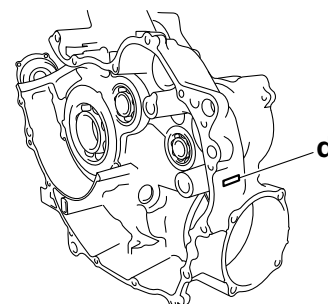

If the left crankcase is marked "9.01",
"e" is 9.01

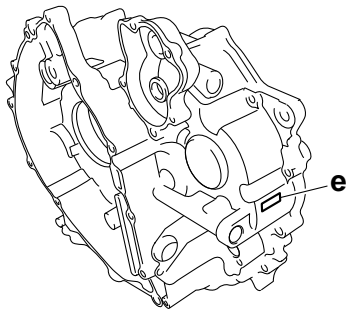

Therefore, "A" is 1.40.

$$"A" = 9.01 + 64.97 - 17.0 - 55.0 - 0.58 = 1.40$$

Round off hundredths digit and select appropriate shim(s).

In the above example, the calculated shim thickness is 1.40 mm. The following chart instructs you, however, to round off 0 to 0.

Hundredth	Rounded value
0, 1, 2	0
3, 4, 5, 6, 7	5
8, 9	10

Shims are supplied in the following thicknesses.



Middle drive pinion gear shim
Thickness (mm)
 0.50 0.55 0.60 0.70 0.80 0.90 1.00

c. To find middle driven pinion gear shim thickness "B", use the following formula.

Middle driven pinion gear shim thickness
 $"B" = "f" - "g" + "h" - "i" - "j" - 0.05$

"f" = a numeral (usually a decimal number) on the bearing housing is either added to or subtracted from "77.5"

TIP

After replacing any part in the middle driven pinion gear assembly, the overall length of the assembly will change. Therefore, be sure to measure distance "f" to select the correct middle driven pinion gear shim thickness.

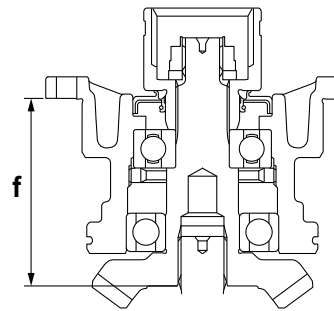

"g" = a numeral (usually a decimal number) on the middle driven pinion gear is either added to or subtracted from "49.0"

"h" = a numeral (usually a decimal number) on the middle driven pinion gear is either added to or subtracted from "80.5"

"i" = a numeral (usually a decimal number) on the left crankcase specifies a thickness of "99.98"

"j" = a numeral (usually a decimal number) on the right crankcase specifies a thickness of "8.12"

Example:

If the bearing housing is marked "+03", "f" is 77.53

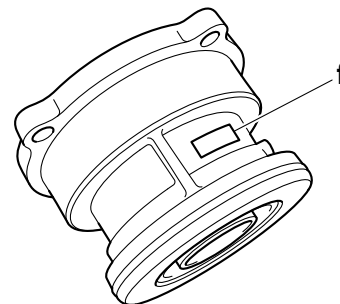

If the driven pinion gear is marked "+0", "g" is 49.0

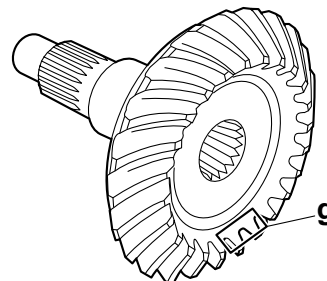

If the driven pinion gear is marked "-10", "h" is 80.40

MIDDLE GEAR

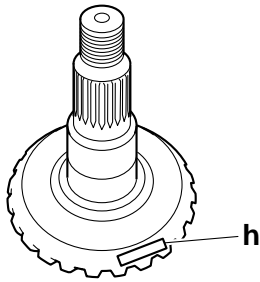

Middle driven pinion gear shim
Thickness (mm)

0.10 0.15 0.20 0.30 0.40 0.50 0.60



If the left crankcase is marked "99.99",
"i" is 99.99

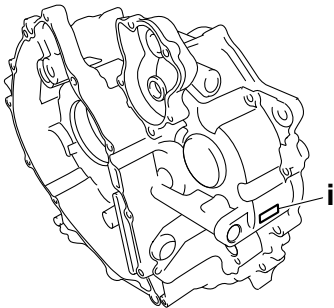

If the right crankcase is marked "8.17",
"j" is 8.17

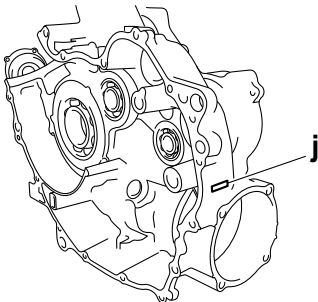

Therefore, "B" is 0.72.

$$\begin{aligned} \text{"B"} &= 77.53 - 49.0 + 80.40 - 99.99 - 8.17 - 0.05 \\ &= 0.72 \end{aligned}$$

Round off hundredth digit and select appropriate shim(s).

In the example above, the calculated shim thickness is 0.72 mm. The chart instructs you, however, to round off 2 to 0.

Hundredth	Rounded value
0, 1, 2	0
3, 4, 5, 6, 7	5
8, 9	10

Shims are supplied in the following thicknesses.

COOLING SYSTEM

RADIATOR	6-1
CHECKING THE RADIATOR.....	6-3
INSTALLING THE RADIATOR.....	6-3
THERMOSTAT	6-4
CHECKING THE THERMOSTAT.....	6-5
INSTALLING THE THERMOSTAT.....	6-5
WATER PUMP	6-7
DISASSEMBLING THE WATER PUMP.....	6-9
CHECKING THE WATER PUMP	6-9
ASSEMBLING THE WATER PUMP.....	6-9

EAS26380

RADIATOR

Removing the radiator

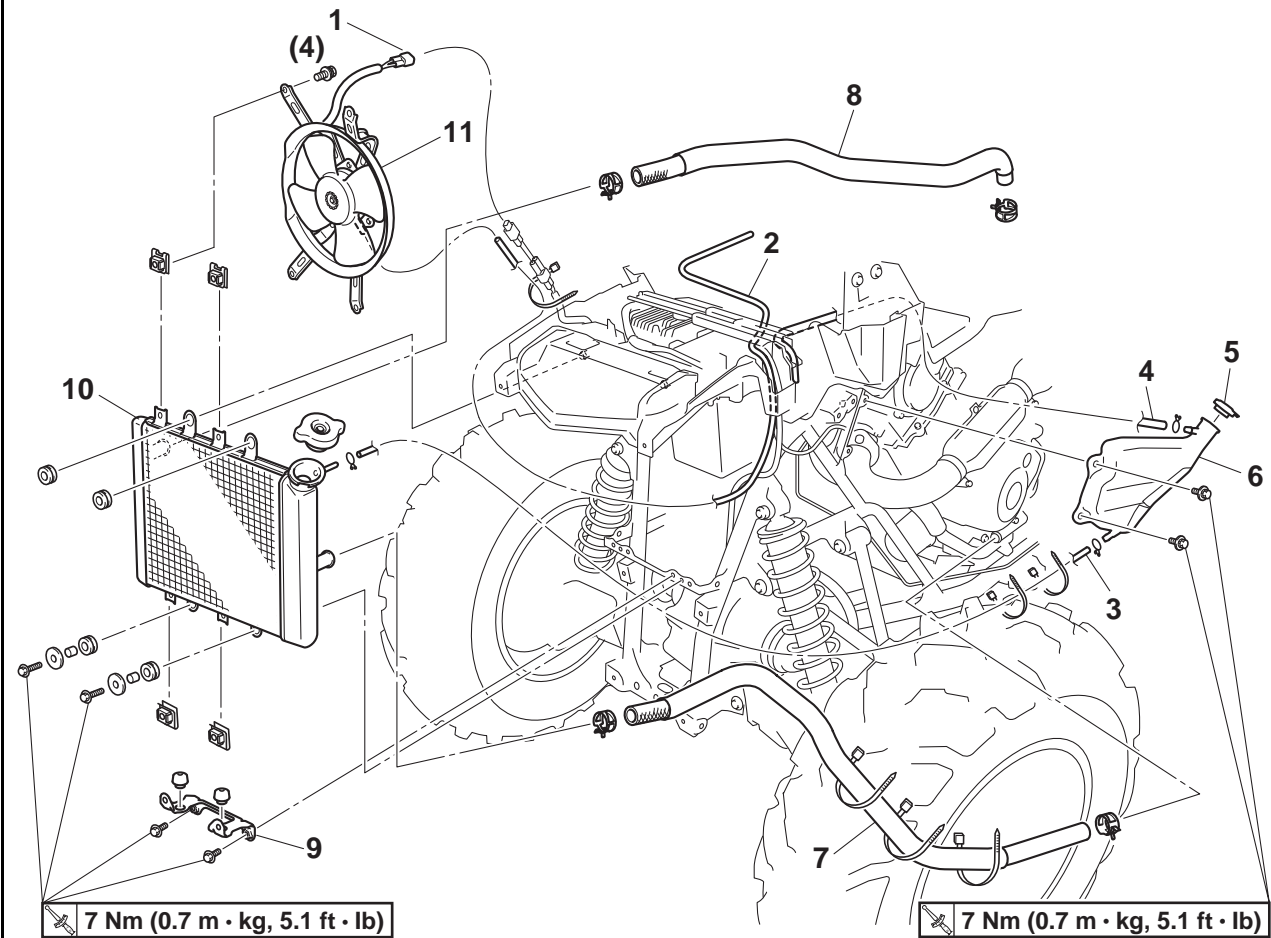

Order	Job/Parts to remove	Q'ty	Remarks
	Front fenders/Front guard/Left footrest board/Air filter case		Refer to "GENERAL CHASSIS" on page 4-1.
	Coolant		Drain. Refer to "CHANGING THE COOLANT" on page 3-16.
1	Radiator fan motor coupler	1	Disconnect.
2	Radiator fan motor breather hose	1	
3	Coolant reservoir hose	1	
4	Coolant reservoir breather hose	1	
5	Coolant reservoir cap	1	
6	Coolant reservoir	1	
7	Radiator outlet hose	1	
8	Radiator inlet hose	1	
9	Radiator bracket	1	
10	Radiator	1	

RADIATOR

Removing the radiator

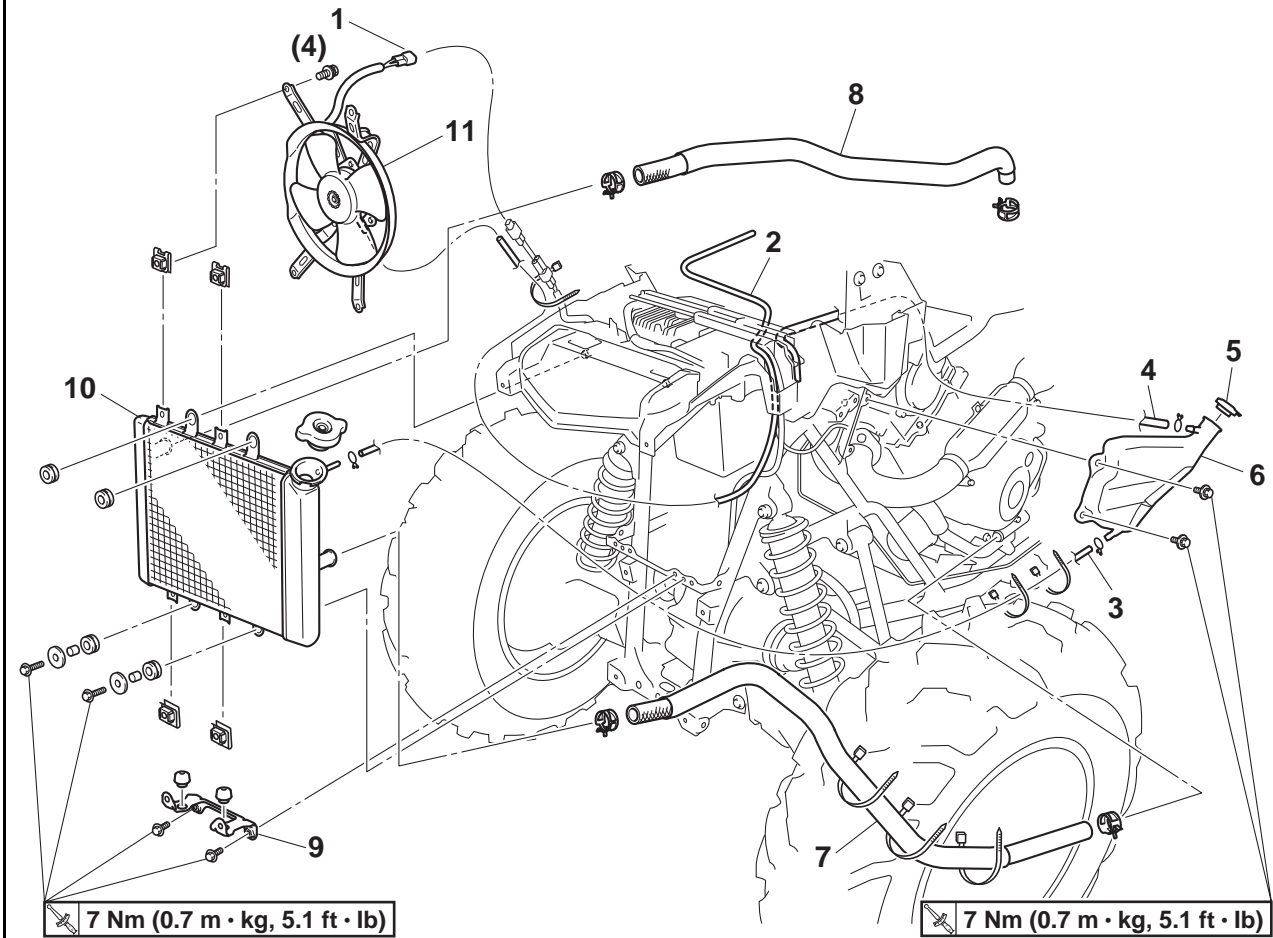

Order	Job/Parts to remove	Q'ty	Remarks
11	Radiator fan	1	
			For installation, reverse the removal procedure.

EAS26440

THERMOSTAT

Removing the thermostat

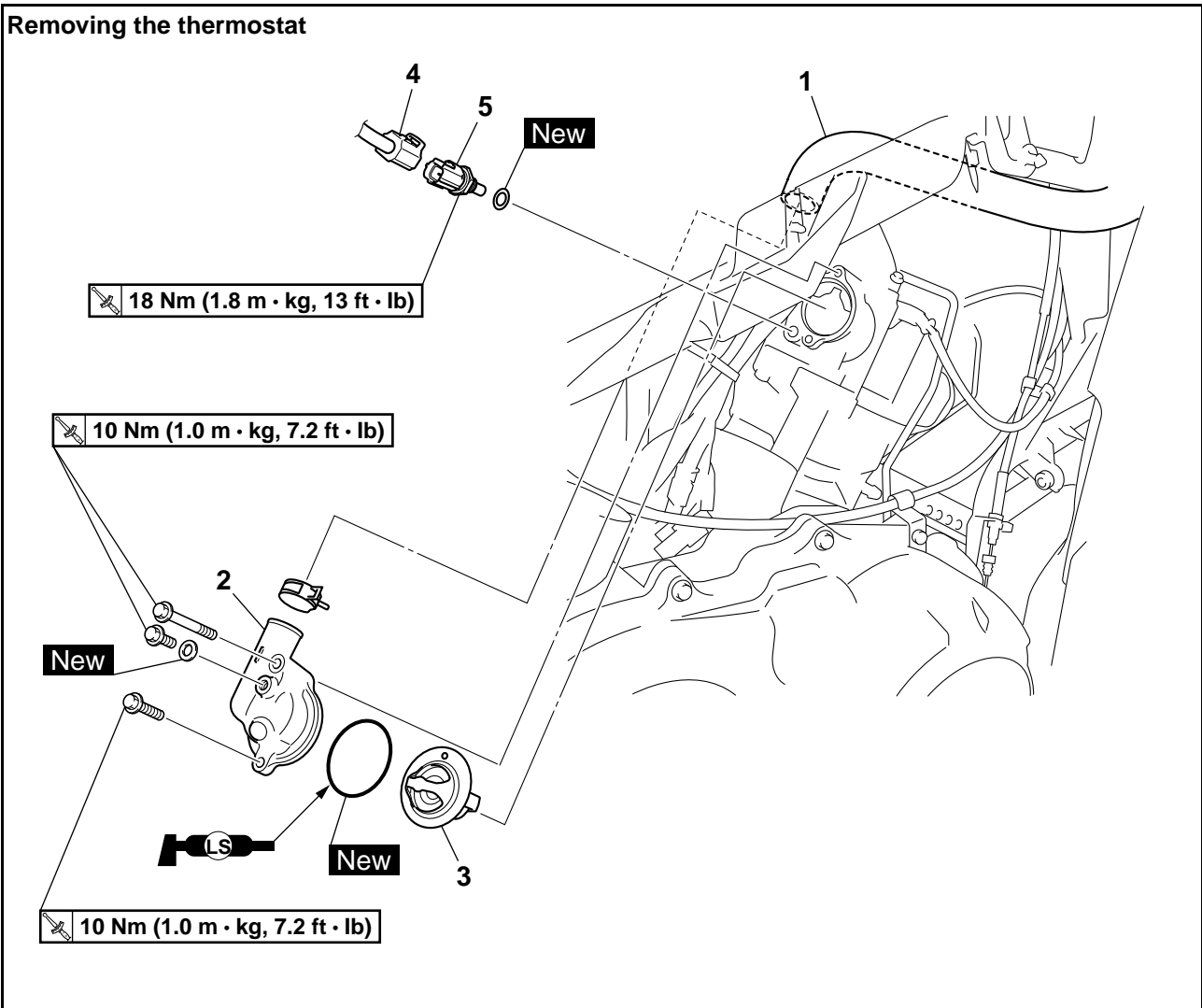

Order	Job/Parts to remove	Q'ty	Remarks
	Air filter case		Refer to "GENERAL CHASSIS" on page 4-1.
	V-belt cooling exhaust duct/V-belt cooling intake duct		Refer to "ENGINE REMOVAL" on page 5-1.
	Coolant		Drain. Refer to "CHANGING THE COOLANT" on page 3-16".
1	Radiator inlet hose	1	Disconnect.
2	Thermostat cover	1	
3	Thermostat	1	
4	Coolant temperature sensor coupler	1	Disconnect.
5	Coolant temperature sensor	1	
			For installation, reverse the removal procedure.

5. Measure:

- Radiator cap opening pressure
Below the specified pressure → Replace the radiator cap.
Refer to “CHECKING THE RADIATOR” on page 6-3.

EAS26500

WATER PUMP

Removing the water pump

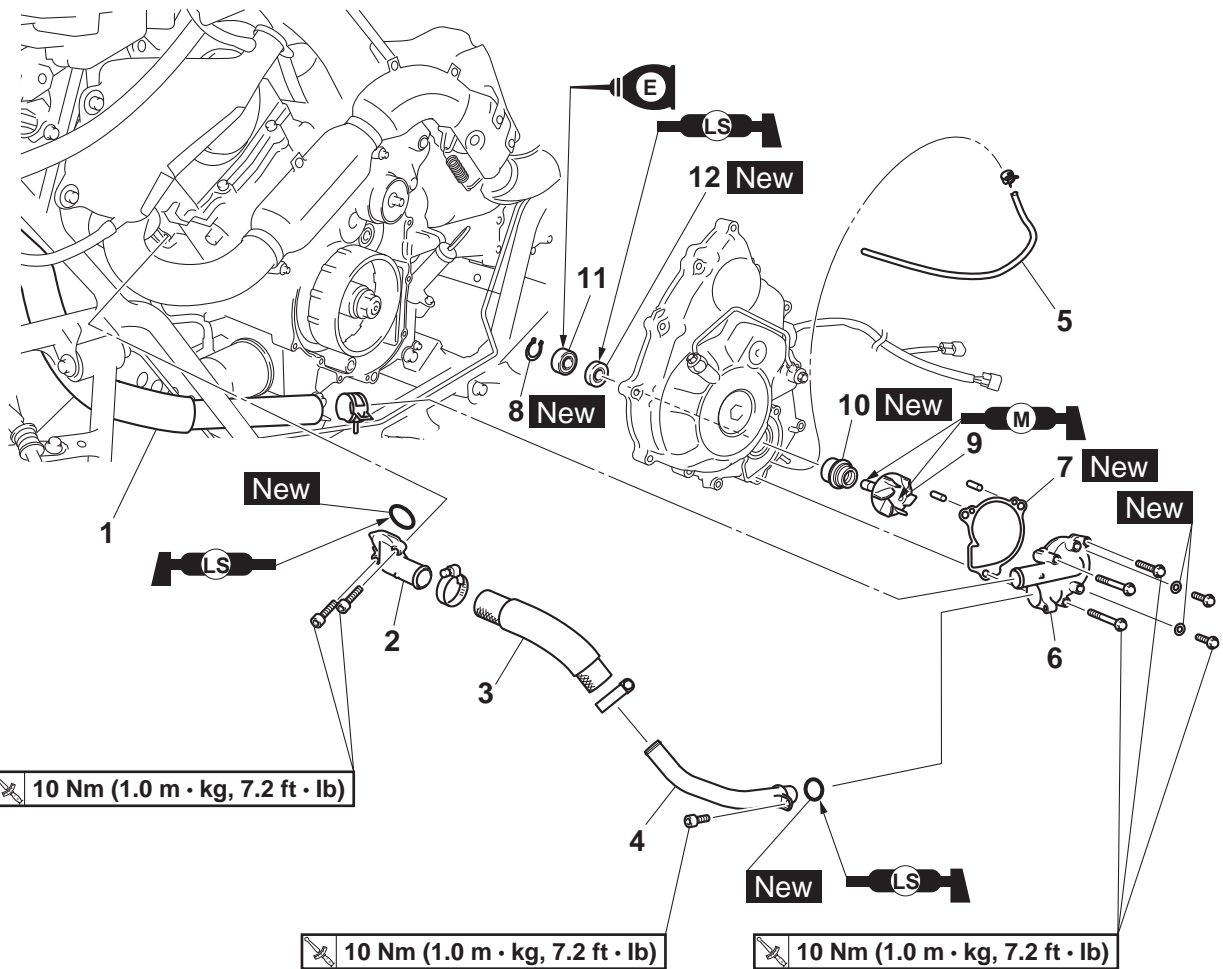

Order	Job/Parts to remove	Q'ty	Remarks
	Left footrest board/Left front fender		Refer to "GENERAL CHASSIS" on page 4-1.
	AC magneto cover		Refer to "AC MAGNETO AND STARTER CLUTCH" on page 5-33.
	Coolant		Drain. Refer to "CHANGING THE COOLANT" on page 3-16.
1	Radiator outlet hose	1	Disconnect.
2	Water jacket joint	1	
3	Water pump outlet hose	1	
4	Water pump outlet pipe	1	
5	Water pump breather hose	1	
6	Water pump housing	1	
7	Gasket	1	
8	Circlip	1	
9	Impeller shaft	1	
10	Water pump seal	1	

WATER PUMP

Removing the water pump

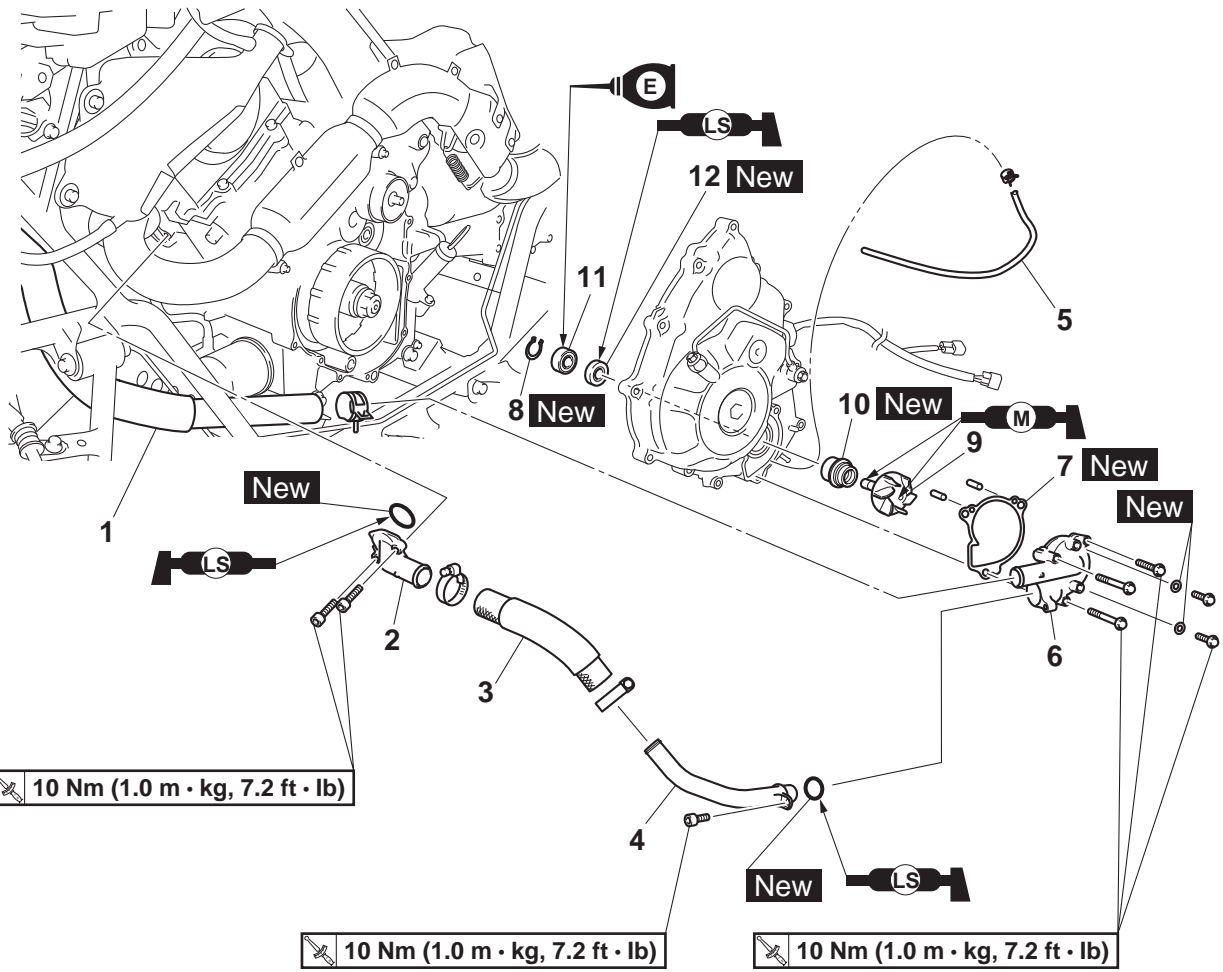

Order	Job/Parts to remove	Q'ty	Remarks
11	Bearing	1	
12	Oil seal	1	
			For installation, reverse the removal procedure.

EAS26510

DISASSEMBLING THE WATER PUMP

1. Remove:
 - Water pump seal "1"

TIP

Remove the water pump seal from the inside of the AC magneto cover "2".

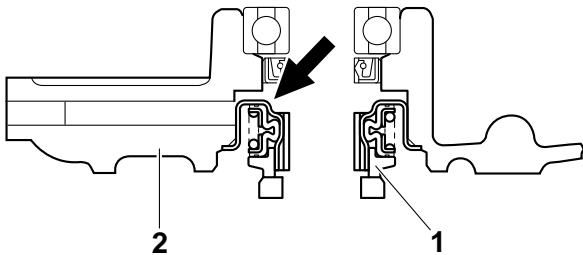

2. Remove:
 - Bearing "1"
 - Oil seal "2"

TIP

Remove the bearing and oil seal from the outside of the AC magneto cover "3".

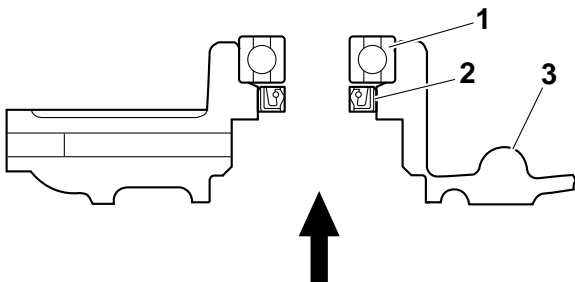

EAS26540

CHECKING THE WATER PUMP

1. Check:
 - Water pump housing
 - Impeller shaft
 - Water pump seal
 - Oil seal

Cracks/damage/wear → Replace.
2. Check:
 - Bearing

Rough movement → Replace.
3. Check:
 - Water jacket joint
 - Water pump outlet pipe
 - Water pump outlet hose

Cracks/damage/wear → Replace.

EAS26560

ASSEMBLING THE WATER PUMP

1. Install:
 - Oil seal "1" **New**
(into the AC magneto cover "2")

TIP

- Before installing the oil seal, apply tap water or coolant onto its outer surface.
- Install the oil seal with a socket "3" that matches its outside diameter.



Installed depth of oil seal "a"
8.1–8.7 mm (0.32–0.34 in)

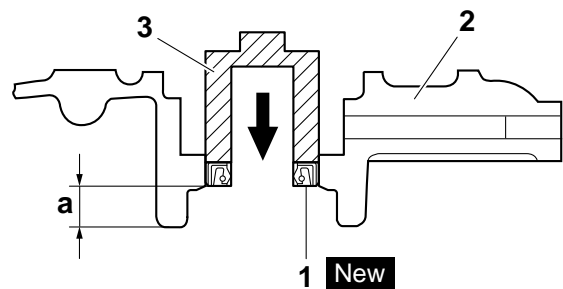

2. Install:
 - Water pump seal "1" **New**
(into the AC magneto cover "2")

ECA14080

NOTICE

Never lubricate the water pump seal surface with oil or grease.

TIP

Install the water pump seal with the special tools.



Mechanical seal installer
90890-04132
Water pump seal installer
YM-33221-A
Middle driven shaft bearing driver
90890-04058
Middle drive bearing installer 40 & 50 mm
YM-04058

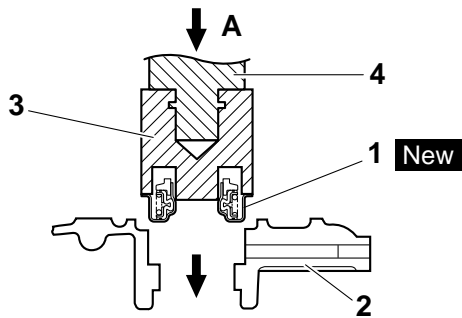

- 3. Mechanical seal installer
- 4. Middle driven shaft bearing driver
- A. Push down.

3. Measure:
- Impeller shaft tilt
- Out of specification → Replace.

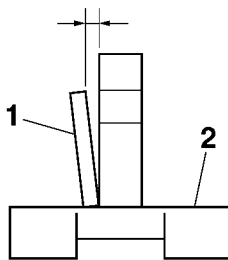
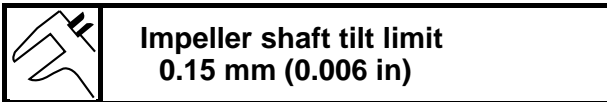

- 1. Straightedge
- 2. Impeller

4. Install:
- Impeller shaft "1"
 - Circlip **New**

TIP _____
After installation, check that the impeller shaft rotates smoothly.

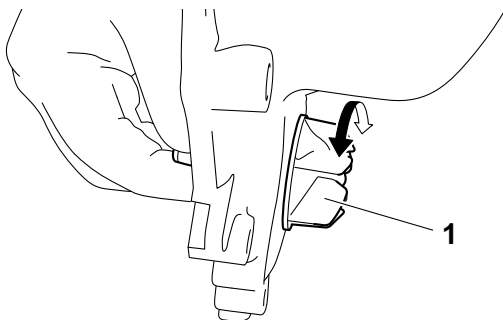

FUEL SYSTEM

FUEL TANK	7-1
REMOVING THE FUEL TANK.....	7-2
REMOVING THE FUEL PUMP.....	7-2
CHECKING THE FUEL PUMP BODY.....	7-2
CHECKING THE FUEL TANK BREATHER HOSE JOINT.....	7-2
INSTALLING THE FUEL PUMP.....	7-2
INSTALLING THE FUEL TANK.....	7-3
THROTTLE BODY	7-4
REMOVING THE THROTTLE BODY ASSEMBLY.....	7-6
CHECKING THE INJECTOR.....	7-6
CHECKING THE THROTTLE BODY.....	7-6
INSTALLING THE THROTTLE BODY ASSEMBLY.....	7-6
CHECKING THE FUEL PRESSURE.....	7-7
ADJUSTING THE THROTTLE POSITION SENSOR.....	7-7
AIR INDUCTION SYSTEM	7-9
CHECKING THE AIR INDUCTION SYSTEM.....	7-13
INSTALLING THE AIR INDUCTION SYSTEM.....	7-13

EAS26620

FUEL TANK

Removing the fuel tank

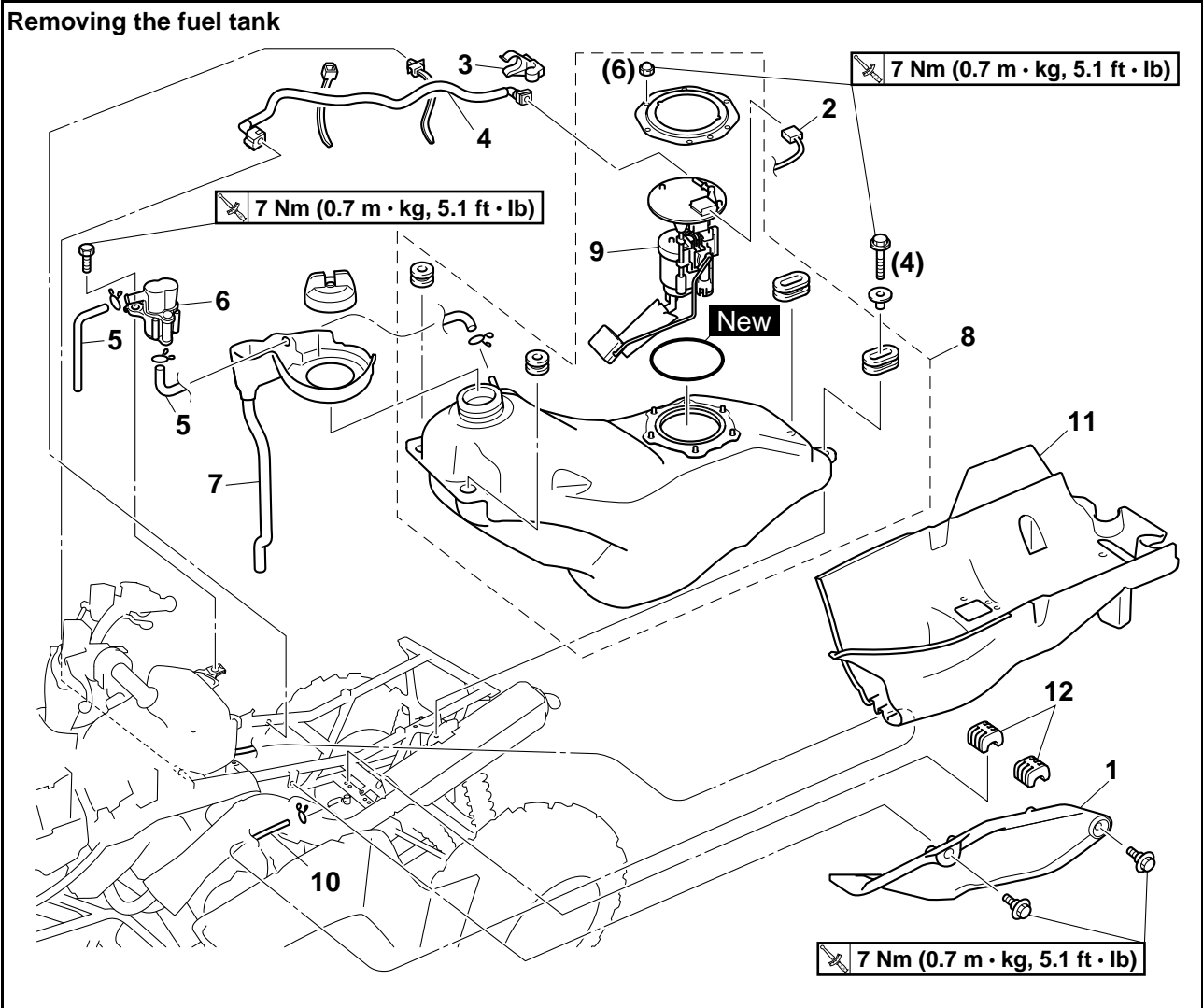

Order	Job/Parts to remove	Q'ty	Remarks
	Rear fender		Refer to "GENERAL CHASSIS" on page 4-1.
1	Fuel tank side cover	1	
2	Fuel pump coupler	1	Disconnect.
3	Fuel hose connector holder	1	
4	Fuel hose	1	
5	Fuel tank breather hose	2	
6	Fuel tank breather hose joint	1	
7	Fuel tank overflow hose	1	
8	Fuel tank	1	
9	Fuel pump assembly	1	
10	Final drive case breather hose	1	Disconnect.
11	Fuel tank shield	1	
12	Damper	2	
			For installation, reverse the removal procedure.

EAS26630

REMOVING THE FUEL TANK

1. Extract the fuel in the fuel tank through the fuel tank cap with a pump.
2. Remove:
 - Fuel hose connector holder
 - Fuel hose

ECA28P1019

NOTICE

- **Be sure to disconnect the fuel hose by hand. Do not forcefully disconnect the hose with tools.**
- **Although the fuel has been removed from the fuel tank, be careful when removing the fuel hose, since there may be fuel remaining in it.**

TIP

- When removing the fuel hose from the fuel pump, remove the fuel hose connector holder first, and next, insert a slotted head screwdriver etc. in the slot part "a" of the fuel hose connector cover "1", then slide it in the direction of the arrow, and remove the fuel hose.
- To remove the fuel hose from the throttle body, slide the fuel hose connector cover "2" on the end of the hose in direction of the arrow shown, press the two buttons "3" on the sides of the connector, and then remove the hose.
- Before removing the hose, place a few rags in the area under where it will be removed.

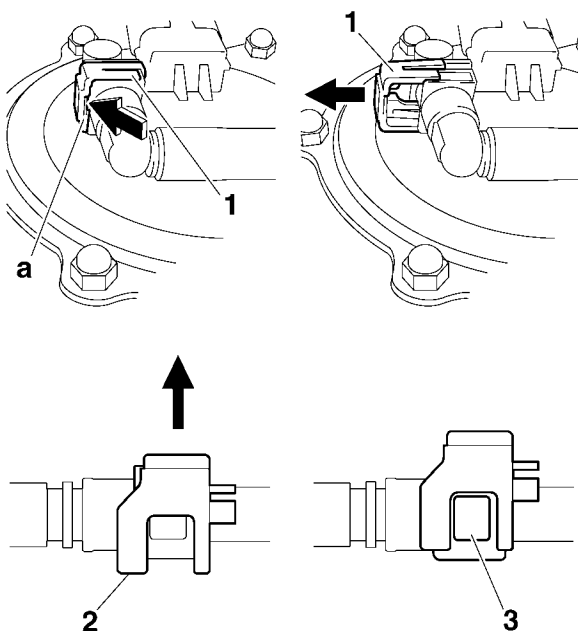

3. Remove:
 - Fuel tank

TIP

Do not set the fuel tank down on the installation surface of the fuel pump. Be sure to lean the fuel tank in an upright position.

EAS26640

REMOVING THE FUEL PUMP

1. Remove:
 - Fuel pump bracket
 - Fuel pump
 - Fuel pump gasket

ECA14720

NOTICE

- **Do not drop the fuel pump or give it a strong shock.**
- **Do not touch the base section of the fuel sender.**

EAS26670

CHECKING THE FUEL PUMP BODY

1. Check:
 - Fuel pump body
 - Obstruction → Clean.
 - Cracks/damage → Replace the fuel pump assembly.

EAS28P1069

CHECKING THE FUEL TANK BREATHER HOSE JOINT

1. Check:
 - Fuel tank breather hose joint
 - Damage/faulty → Replace.

EAS26700

INSTALLING THE FUEL PUMP

1. Install:
 - Fuel pump gasket **New**
 - Fuel pump
 - Fuel pump bracket



Fuel pump nut
7 Nm (0.7 m·kg, 5.1 ft·lb)

TIP

- Do not damage the installation surfaces of the fuel tank when installing the fuel pump.
- Always use a new fuel pump gasket.
- Install the fuel pump in the direction shown in the illustration.
- Install the fuel pump bracket by aligning the projections "a" on the fuel pump with the projections on the fuel tank.
- Tighten the fuel pump nuts in the proper tightening sequence as shown.

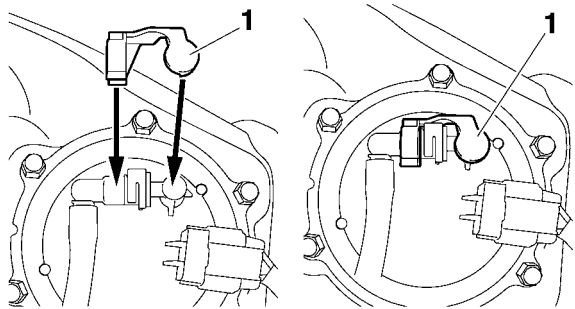
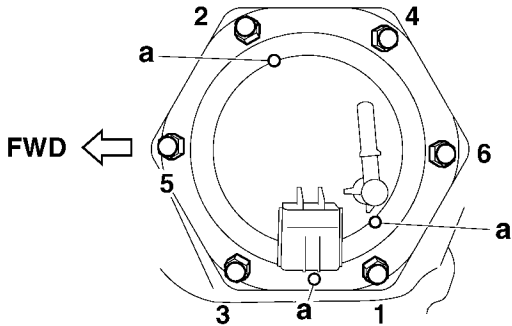

EAS28P1021

INSTALLING THE FUEL TANK

- 1. Install:
 - Dampers "1"

TIP

Fit the projections on each damper into the 3rd and 4th holes in the frame. Determine the 3rd and 4th holes by counting outward from the center hole in the frame.

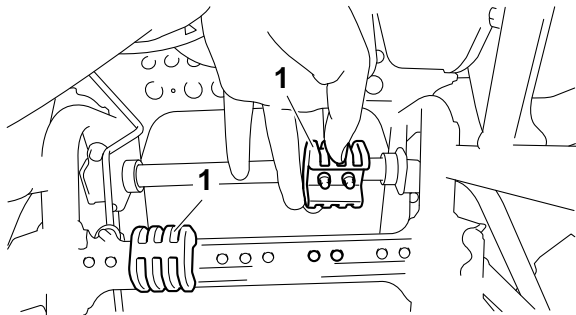
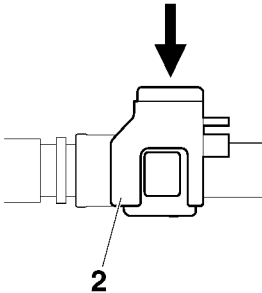

- 2. Install:
 - Fuel hose
 - Fuel hose connector holder "1"
 - Fuel pump coupler

ECA28P1020

NOTICE

When installing the fuel hose, make sure that it is securely connected, and that the fuel hose holder is in the correct position, otherwise the fuel hose will not be properly installed.

TIP

- Install the fuel hose connector holder "1" securely onto the fuel pump until a distinct "click" is heard, and then make sure that it does not come loose.
- To install the fuel hose onto the throttle body, slide the fuel hose connector cover "2" on the end of the hose in direction of the arrow shown.

EAS26970

THROTTLE BODY

Removing the throttle body

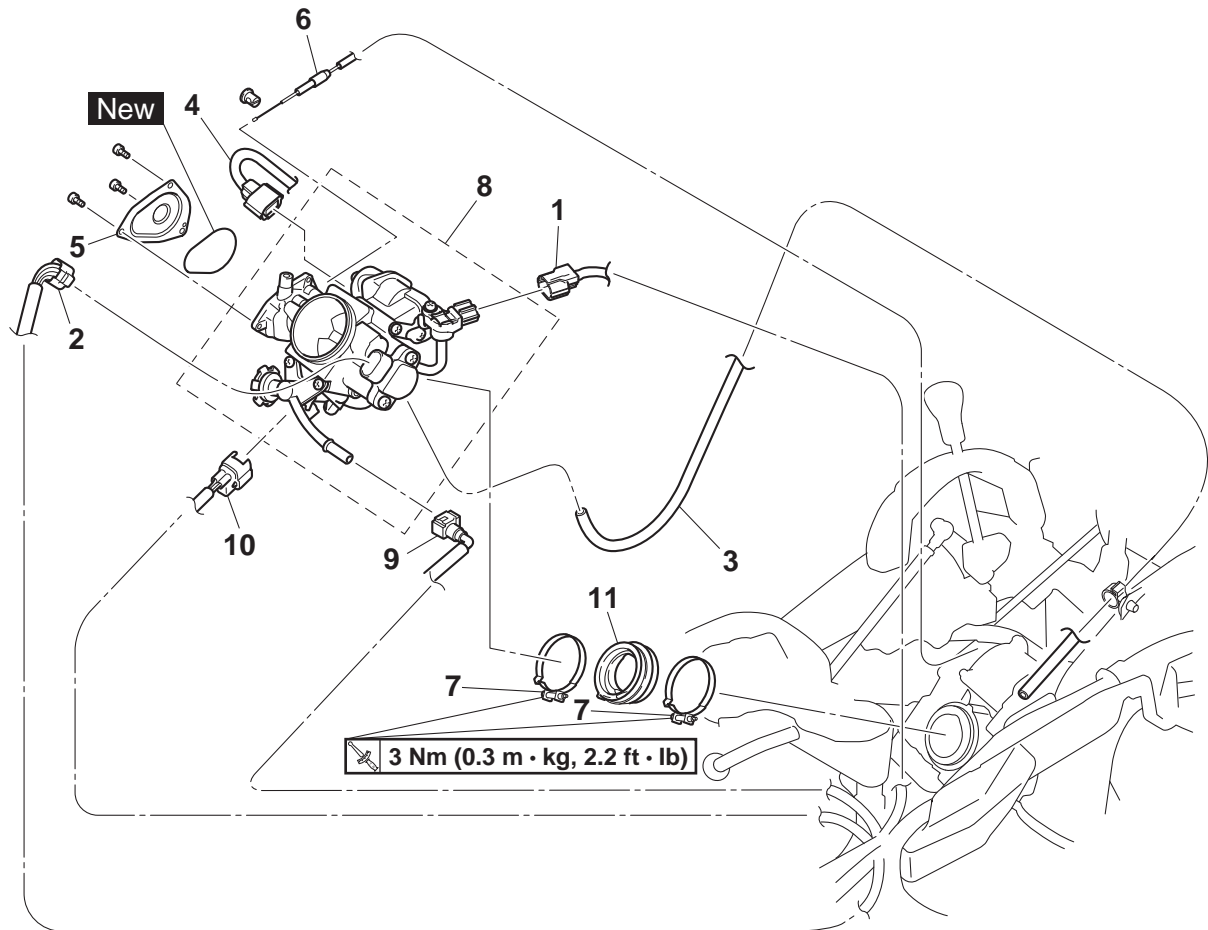

Order	Job/Parts to remove	Q'ty	Remarks
	Air filter case		Refer to "GENERAL CHASSIS" on page 4-1.
1	Intake air pressure sensor coupler	1	Disconnect.
2	Throttle position sensor coupler	1	Disconnect.
3	Throttle body breather hose	1	
4	ISC unit coupler	1	Disconnect.
5	Throttle cable housing cover	1	
6	Throttle cable	1	Disconnect.
7	Throttle body joint clamp screw	2	Loosen.
8	Throttle body assembly	1	
9	Fuel hose	1	Disconnect.
10	Fuel injector coupler	1	Disconnect.
11	Throttle body joint	1	
			For installation, reverse the removal procedure.

THROTTLE BODY

Disassembling the throttle body assembly

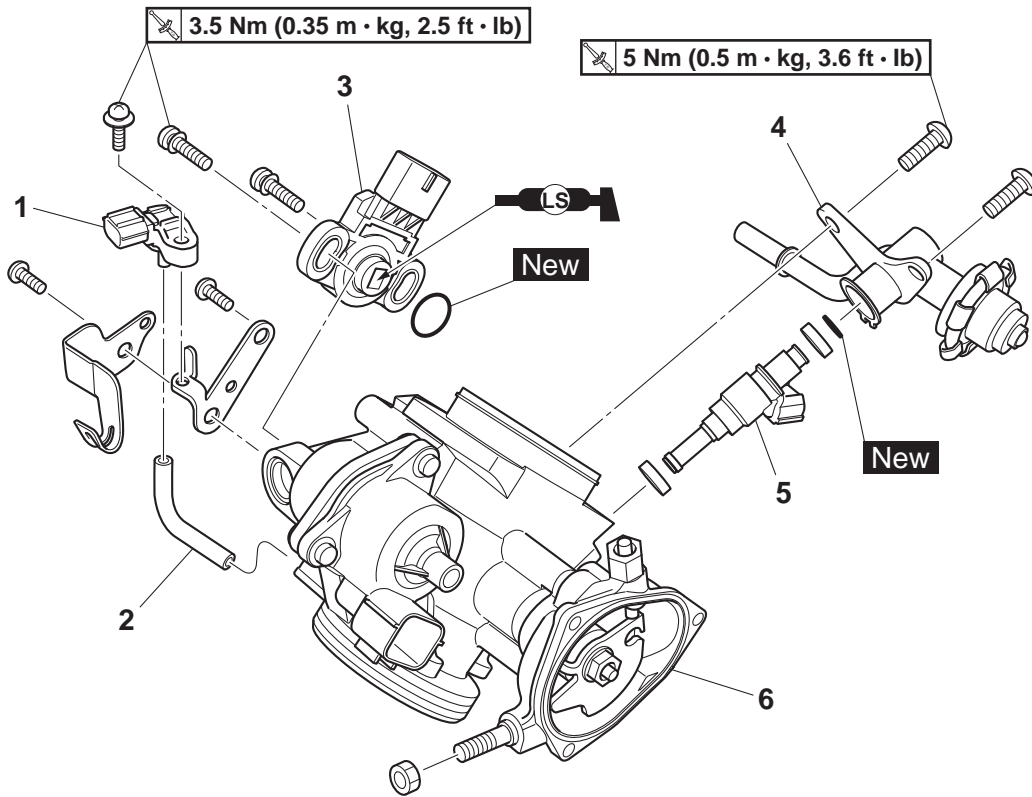

Order	Job/Parts to remove	Q'ty	Remarks
1	Intake air pressure sensor	1	
2	Intake air pressure sensor hose	1	
3	Throttle position sensor	1	
4	Fuel rail	1	
5	Fuel injector	1	
6	Throttle body	1	ECA28P1021 NOTICE The throttle body should not be disassembled.
			For assembly, reverse the disassembly procedure.

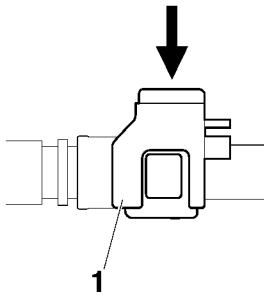

EAS27010

CHECKING THE FUEL PRESSURE

1. Check:

- Fuel pressure



a. Remove the rear fender.

Refer to "GENERAL CHASSIS" on page 4-1.

b. Remove the fuel hose connector holder.

c. Disconnect the fuel hose "1" from the fuel pump.

TIP

- When removing the fuel hose from the fuel pump, remove the fuel hose connector holder first, and next, insert a slotted head screwdriver etc. in the slot part "a" of the fuel hose connector cover "2", then slide it in the direction of the arrow, and remove the fuel hose.
- Before removing the hose, place a few rags in the area under where it will be removed.

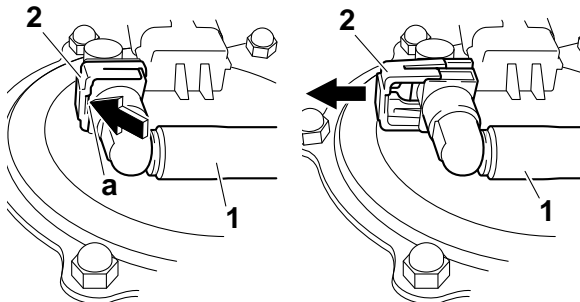

d. Connect the pressure gauge "3" and adapter "4" to the fuel pump and fuel hose.



Pressure gauge
90890-03153
YU-03153
Fuel pressure adapter
90890-03176
YM-03176

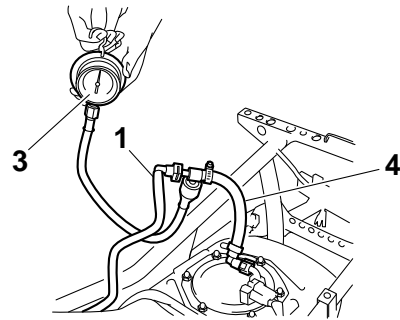

- Start the engine.
- Measure the fuel pressure.
Out of specification → Replace the fuel pump.



Fuel pressure
324 kPa (3.24 kgf/cm², 46.1 psi)

EAS27030

ADJUSTING THE THROTTLE POSITION SENSOR

1. Check:

- Throttle position sensor
Refer to "CHECKING THE THROTTLE POSITION SENSOR" on page 9-95.

2. Adjust:

- Throttle position sensor angle



- Connect the throttle position sensor coupler to the throttle position sensor.
- Connect the digital circuit tester to the throttle position sensor coupler.

- Positive tester probe
yellow "1"
- Negative tester probe
black/blue "2"



Digital circuit tester
90890-03174
Model 88 Multimeter with tachometer
YU-A1927

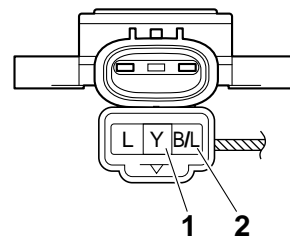

THROTTLE BODY

- c. Turn the main switch to “ON”.
- d. Measure the throttle position sensor voltage.
- e. Adjust the throttle position sensor angle so that the voltage is within the specified range.

	Throttle position sensor output voltage 0.63–0.73 V (yellow–black/blue)
---	--

- f. After adjusting the throttle position sensor angle, tighten the throttle position sensor screws “3”.

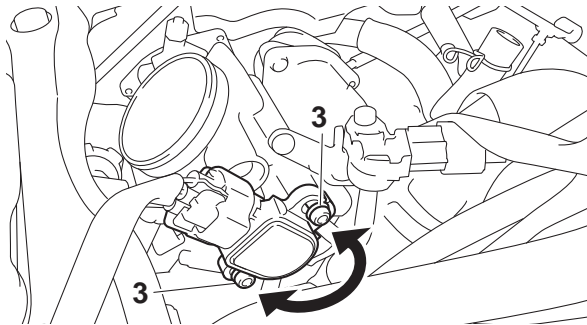

EAS27040

AIR INDUCTION SYSTEM

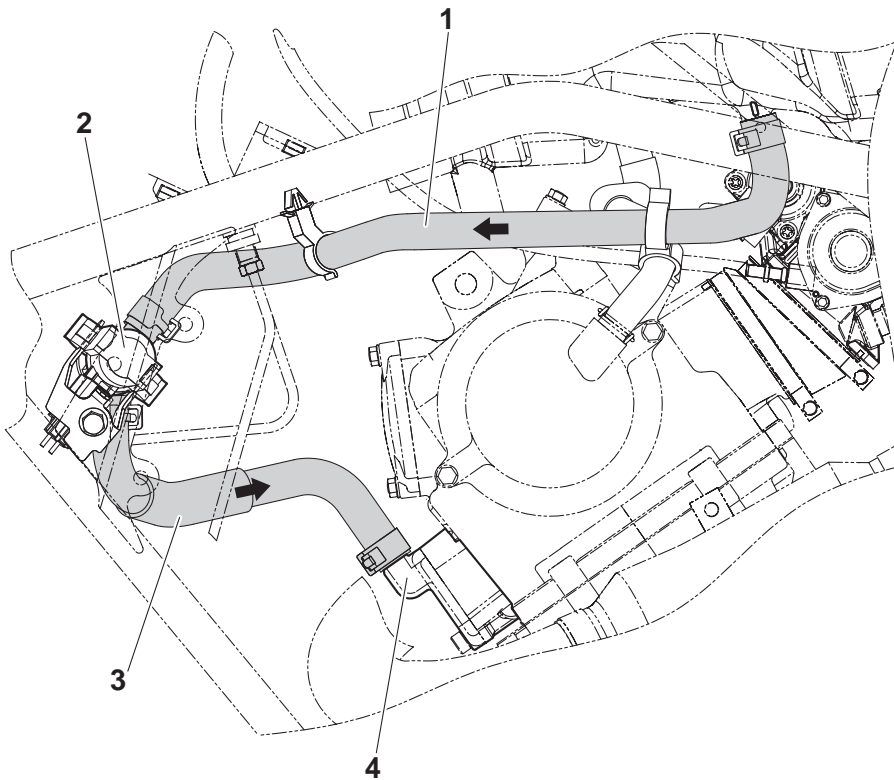
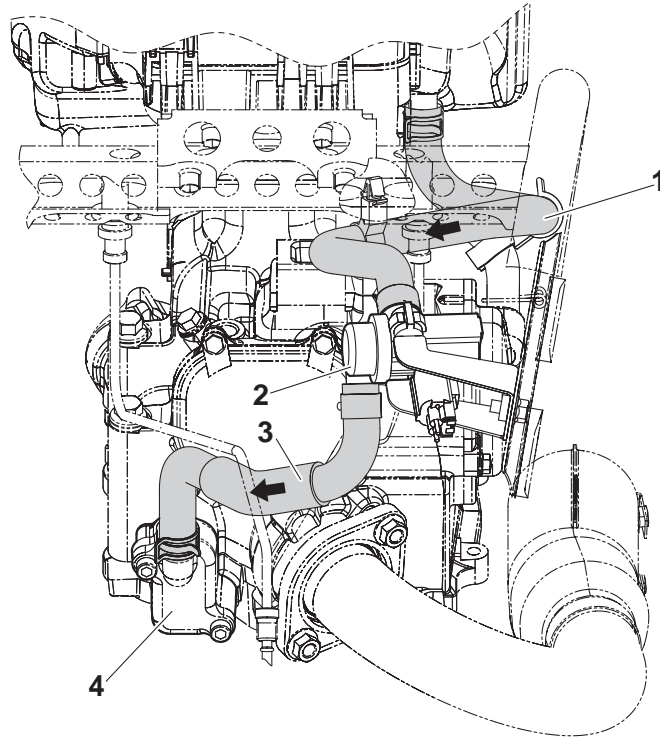

AIR INDUCTION SYSTEM

1. Air induction system hose (air filter case to air cut-off valve)
2. Air cut-off valve
3. Air induction system hose (air cut-off valve to reed valve assembly)
4. Reed valve assembly

AIR INDUCTION SYSTEM

Removing the air cut-off valve

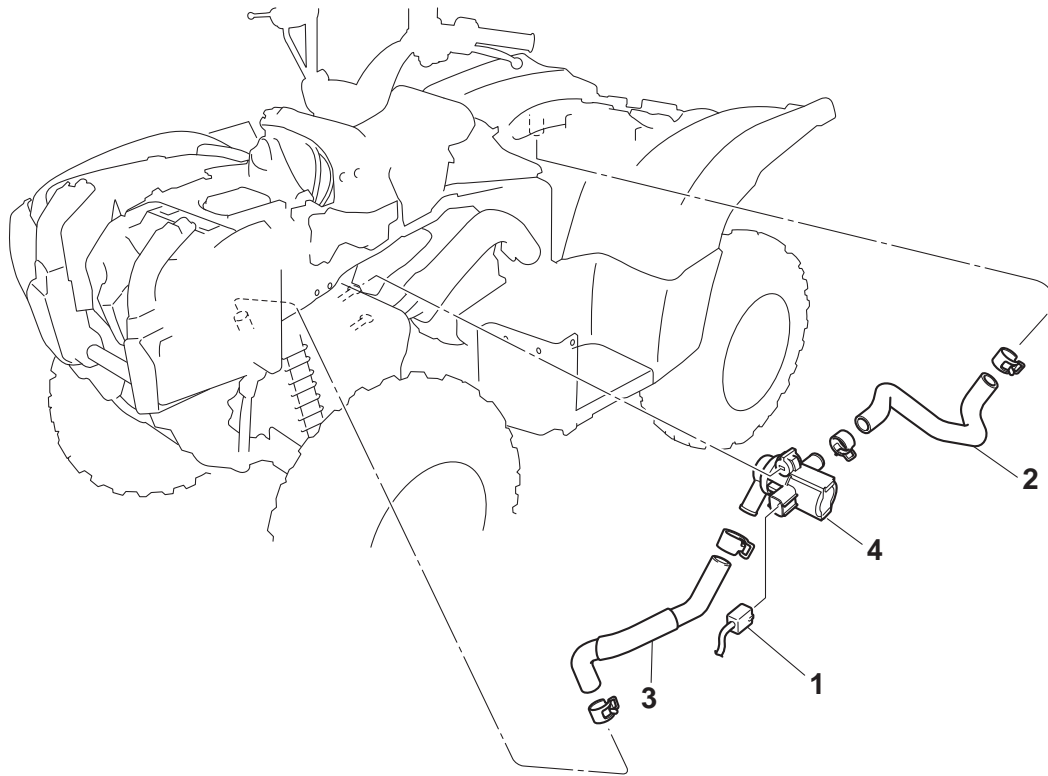

Order	Job/Parts to remove	Q'ty	Remarks
	Side panels		Refer to "GENERAL CHASSIS" on page 4-1.
	Front fender		Refer to "GENERAL CHASSIS" on page 4-1.
1	Air induction system solenoid coupler	1	Disconnect.
2	Air induction system hose (air filter case to air cut-off valve)	1	
3	Air induction system hose (air cut-off valve to reed valve assembly)	1	
4	Air cut-off valve	1	
			For installation, reverse the removal procedure.

AIR INDUCTION SYSTEM

Removing the reed valve

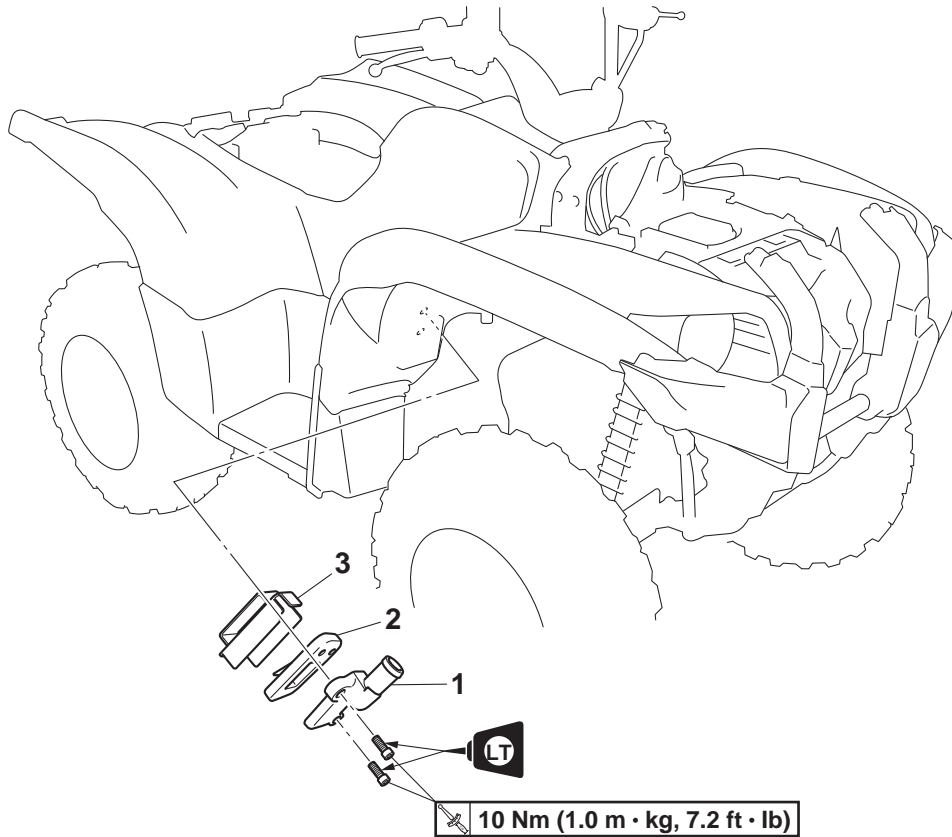

Order	Job/Parts to remove	Q'ty	Remarks
	Side panels		Refer to "GENERAL CHASSIS" on page 4-1.
	Air induction system hoses		Refer to "Removing the air cut-off valve".
1	Reed valve cover	1	
2	Reed valve assembly	1	
3	Reed valve plate	1	
			For installation, reverse the removal procedure.

EAS27060

CHECKING THE AIR INDUCTION SYSTEM

Air injection

The air induction system burns unburned exhaust gases by injecting fresh air (secondary air) into the exhaust port, reducing the emission of hydrocarbons. When there is negative pressure at the exhaust port, the reed valve opens, allowing secondary air to flow into the exhaust port. The required temperature for burning the unburned exhaust gases is approximately 600 to 700 °C (1112 to 1292 °F).

Air cut-off valve

The air cut-off valve is controlled by the signals from the ECU in accordance with the combustion conditions. Ordinarily, the air cut-off valve opens to allow the air to flow during idle and closes to cut-off the flow when the vehicle is being driven. However, if the coolant temperature is below the specified value, the air cut-off valve remains open and allows the air to flow into the exhaust pipe until the temperature becomes higher than the specified value.

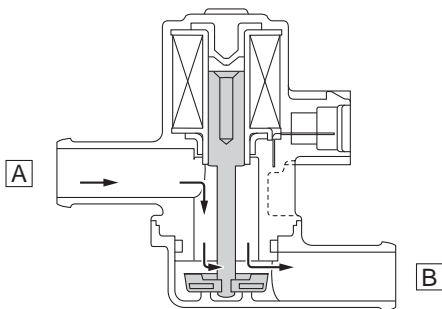
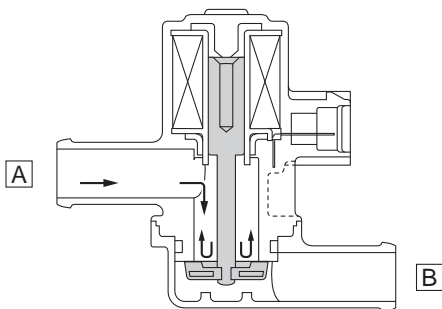

- A. From the air filter case
- B. To the reed valve

1. Check:

- Hoses
Loose connections → Connect properly.
Cracks/damage → Replace.

2. Check:

- Reed valve
- Reed valve stopper
- Reed valve seat
Cracks/damage → Replace the reed valve assembly.

3. Check:

- Air cut-off valve
Cracks/damage → Replace.

4. Check:

- Air induction system solenoid
Refer to "CHECKING THE AIR INDUCTION SYSTEM SOLENOID" on page 9-96.

EAS27070

INSTALLING THE AIR INDUCTION SYSTEM

1. Install:

- Reed valve plate "1"

TIP

Align the notch "a" in the reed valve plate with the projection "b" of the reed valve seat on the cylinder head.

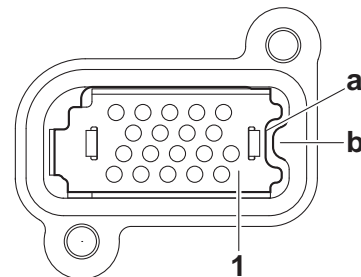

DRIVE TRAIN

TROUBLESHOOTING	8-1
CHECKING NOISES.....	8-1
TROUBLESHOOTING CHART.....	8-2
FRONT CONSTANT VELOCITY SHAFT ASSEMBLIES, DIFFERENTIAL ASSEMBLY AND FRONT DRIVE SHAFT	8-3
DISASSEMBLING THE FRONT CONSTANT VELOCITY SHAFT ASSEMBLIES.....	8-9
CHECKING THE FRONT CONSTANT VELOCITY SHAFT ASSEMBLIES.....	8-9
ASSEMBLING THE FRONT CONSTANT VELOCITY SHAFT ASSEMBLIES.....	8-10
REMOVING THE DIFFERENTIAL GEAR ASSEMBLY.....	8-11
CHECKING THE DIFFERENTIAL ASSEMBLY.....	8-11
CHECKING THE DIFFERENTIAL MOTOR.....	8-11
ASSEMBLING THE DIFFERENTIAL ASSEMBLY.....	8-12
MEASURING THE DIFFERENTIAL GEAR BACKLASH.....	8-13
ADJUSTING THE DIFFERENTIAL GEAR BACKLASH.....	8-13
REAR CONSTANT VELOCITY SHAFT ASSEMBLIES, FINAL DRIVE ASSEMBLY AND REAR DRIVE SHAFT	8-15
DISASSEMBLING THE REAR CONSTANT VELOCITY SHAFT ASSEMBLIES.....	8-22
CHECKING THE REAR CONSTANT VELOCITY SHAFT ASSEMBLIES.....	8-22
ASSEMBLING THE REAR CONSTANT VELOCITY SHAFT ASSEMBLIES.....	8-23
DISASSEMBLING THE FINAL DRIVE PINION GEAR ASSEMBLY.....	8-24
CHECKING THE REAR DRIVE SHAFT.....	8-24
CHECKING THE FINAL DRIVE ASSEMBLY.....	8-24
ASSEMBLING THE FINAL DRIVE CASE.....	8-25
ASSEMBLING THE FINAL DRIVE PINION GEAR ASSEMBLY.....	8-25
SELECTING THE FINAL DRIVE PINION GEAR SHIM(S).....	8-25
SELECTING THE FINAL DRIVEN PINION GEAR SHIM (FINAL DRIVE CASE SIDE) AND THRUST WASHER.....	8-26
SELECTING THE FINAL DRIVEN PINION GEAR SHIM (FINAL DRIVE CASE COVER SIDE).....	8-28
SELECTING THE WHEEL GEAR SHIM(S).....	8-29
MEASURING THE FINAL GEAR BACKLASH.....	8-29
ADJUSTING THE FINAL GEAR BACKLASH.....	8-30

TROUBLESHOOTING

- Always clean the vehicle and recheck the suspected location of an apparent leakage.



EAS29910

TROUBLESHOOTING CHART

When basic conditions (a) and (b) exist, check the following points:

1. Elevate and spin both wheels. Feel for wheel bearing damage.	YES →	Replace the wheel bearing. (Refer to "TIE-RODS AND STEERING KNUCKLES" on page 4-56 and "REAR KNUCKLES AND STABILIZER" on page 4-65.)
NO ↓		
2. Check the wheel nuts and axle nuts for tightness.	NO →	Torque to specification. (Refer to "FRONT WHEELS" on page 4-14 and "REAR WHEELS" on page 4-18.)
YES ↓		
3. Check the front constant velocity shaft assemblies. Feel for bearing damage.	NO →	Constant velocity shaft bearings and differential bearings are probably not damaged. Repeat the test or remove the individual components.
YES ↓		
4. Check the rear brake adjustment.	NO →	Adjust per instructions. (Refer to "ADJUSTING THE REAR DISC BRAKE" on page 3-19.)
YES ↓		
5. Check the rear constant velocity shaft assemblies. Feel for bearing damage.	NO →	Constant velocity shaft bearings and final gear bearings are probably not damaged. Repeat the test or remove the individual components.
YES ↓		
Remove the shaft drive components.		

FRONT CONSTANT VELOCITY SHAFT ASSEMBLIES, DIFFERENTIAL ASSEMBLY AND FRONT DRIVE SHAFT

EAS29920

FRONT CONSTANT VELOCITY SHAFT ASSEMBLIES, DIFFERENTIAL ASSEMBLY AND FRONT DRIVE SHAFT

Removing the front constant velocity shaft assemblies, differential assembly and front drive shaft

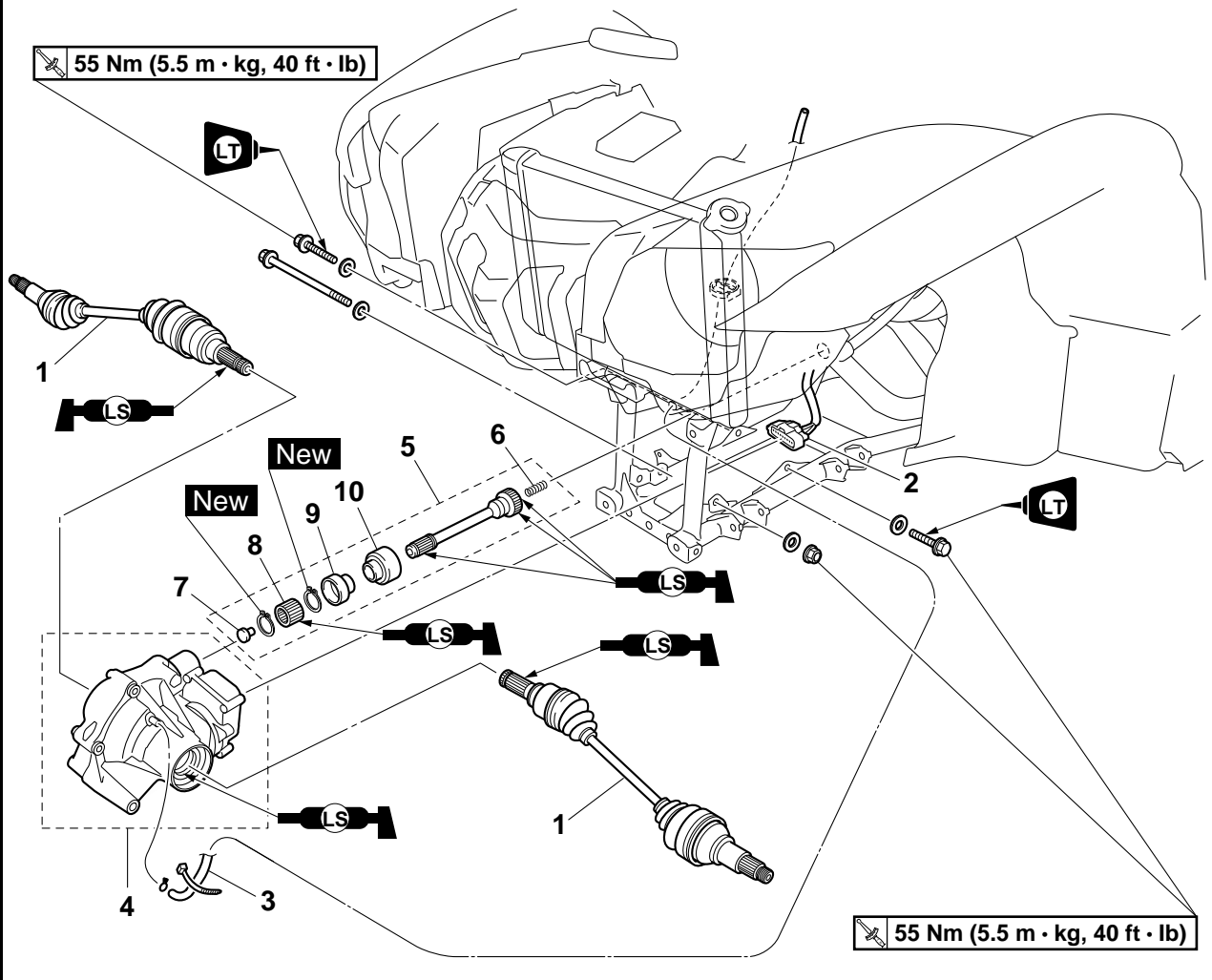

Order	Job/Parts to remove	Q'ty	Remarks
	Front engine skid plate		Refer to "GENERAL CHASSIS" on page 4-1.
	Steering knuckles		Refer to "TIE-RODS AND STEERING KNUCKLES" on page 4-56.
	Front arms		Refer to "FRONT ARMS AND FRONT SHOCK ABSORBER ASSEMBLIES" on page 4-60.
	Differential gear oil		Drain. Refer to "CHANGING THE DIFFERENTIAL GEAR OIL" on page 3-25.
1	Front constant velocity shaft assembly	2	
2	Differential motor coupler	1	Disconnect.
3	Differential case breather hose	1	Disconnect.
4	Differential assembly	1	
5	Front drive shaft	1	
6	Spring	1	
7	Damper	1	

FRONT CONSTANT VELOCITY SHAFT ASSEMBLIES, DIFFERENTIAL ASSEMBLY AND FRONT DRIVE SHAFT

Removing the front constant velocity shaft assemblies, differential assembly and front drive shaft

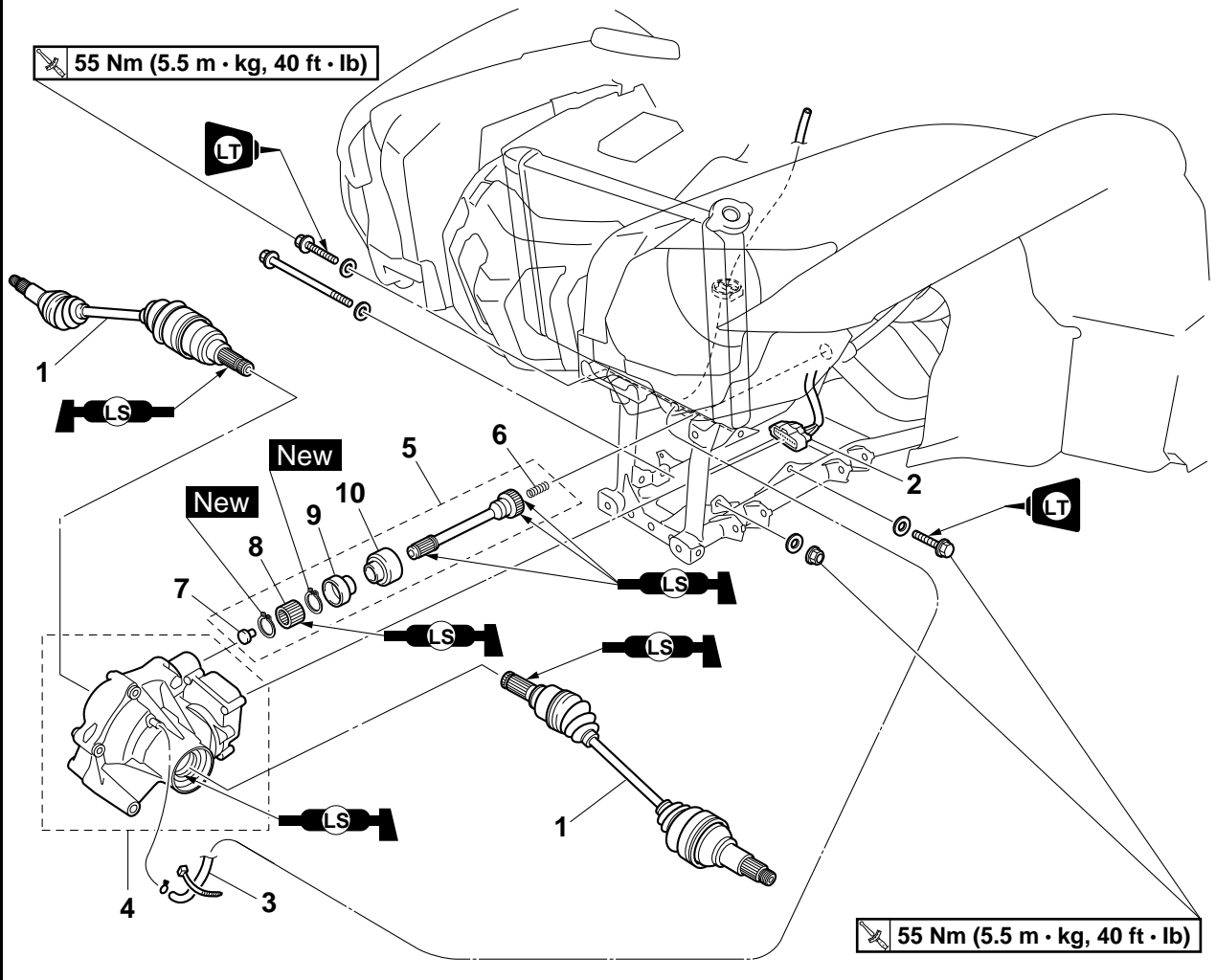

Order	Job/Parts to remove	Q'ty	Remarks
8	Front drive shaft coupling sleeve	1	
9	Dust seal	1	
10	Dust seal	1	
			For installation, reverse the removal procedure.

FRONT CONSTANT VELOCITY SHAFT ASSEMBLIES, DIFFERENTIAL ASSEMBLY AND FRONT DRIVE SHAFT

Disassembling the front constant velocity shaft assemblies

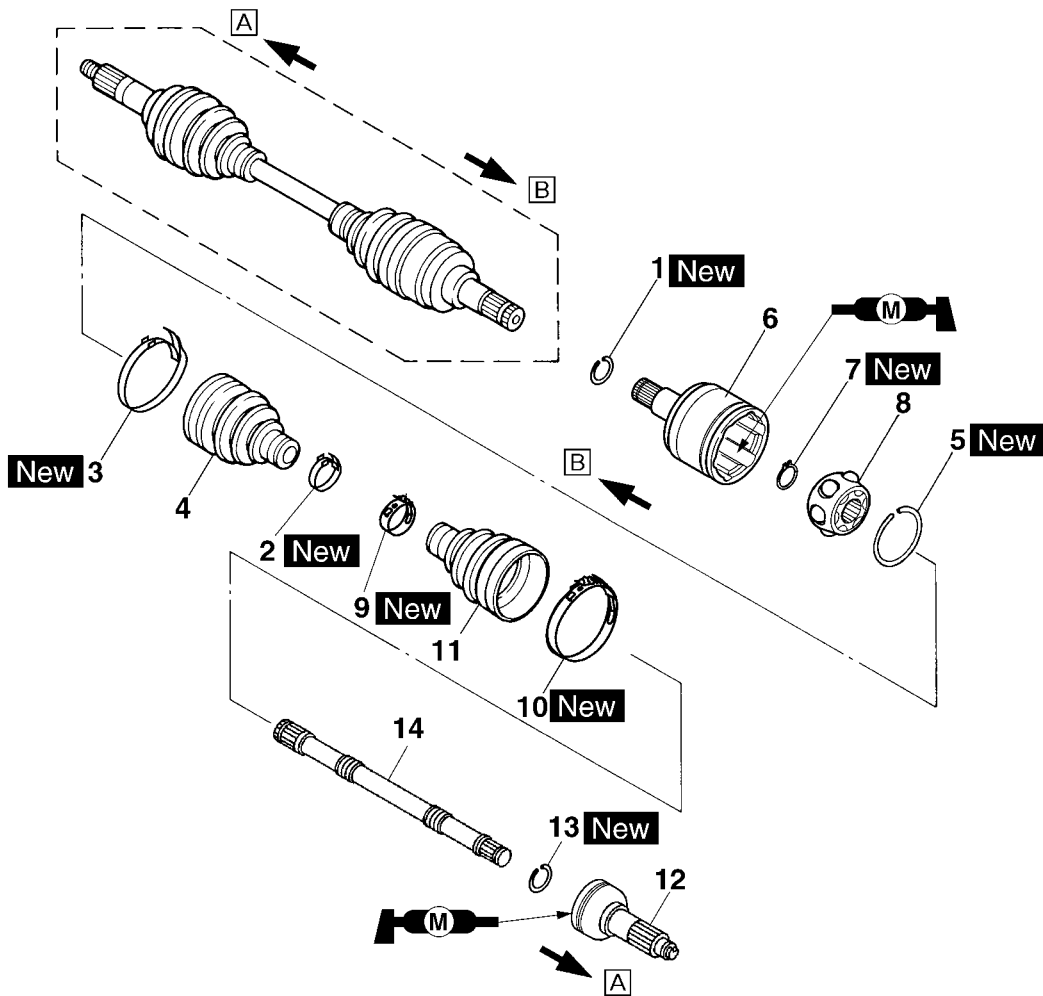

Order	Job/Parts to remove	Q'ty	Remarks
			The following procedure applies to both of the front constant velocity shaft assemblies.
1	Clip	1	
2	Boot band	1	
3	Boot band	1	
4	Dust boot	1	
5	Clip	1	
6	Double offset joint	1	
7	Circlip	1	
8	Ball bearing	1	
9	Boot band	1	
10	Boot band	1	
11	Dust boot	1	
12	Constant velocity joint	1	
13	Clip	1	

FRONT CONSTANT VELOCITY SHAFT ASSEMBLIES, DIFFERENTIAL ASSEMBLY AND FRONT DRIVE SHAFT

Disassembling the front constant velocity shaft assemblies

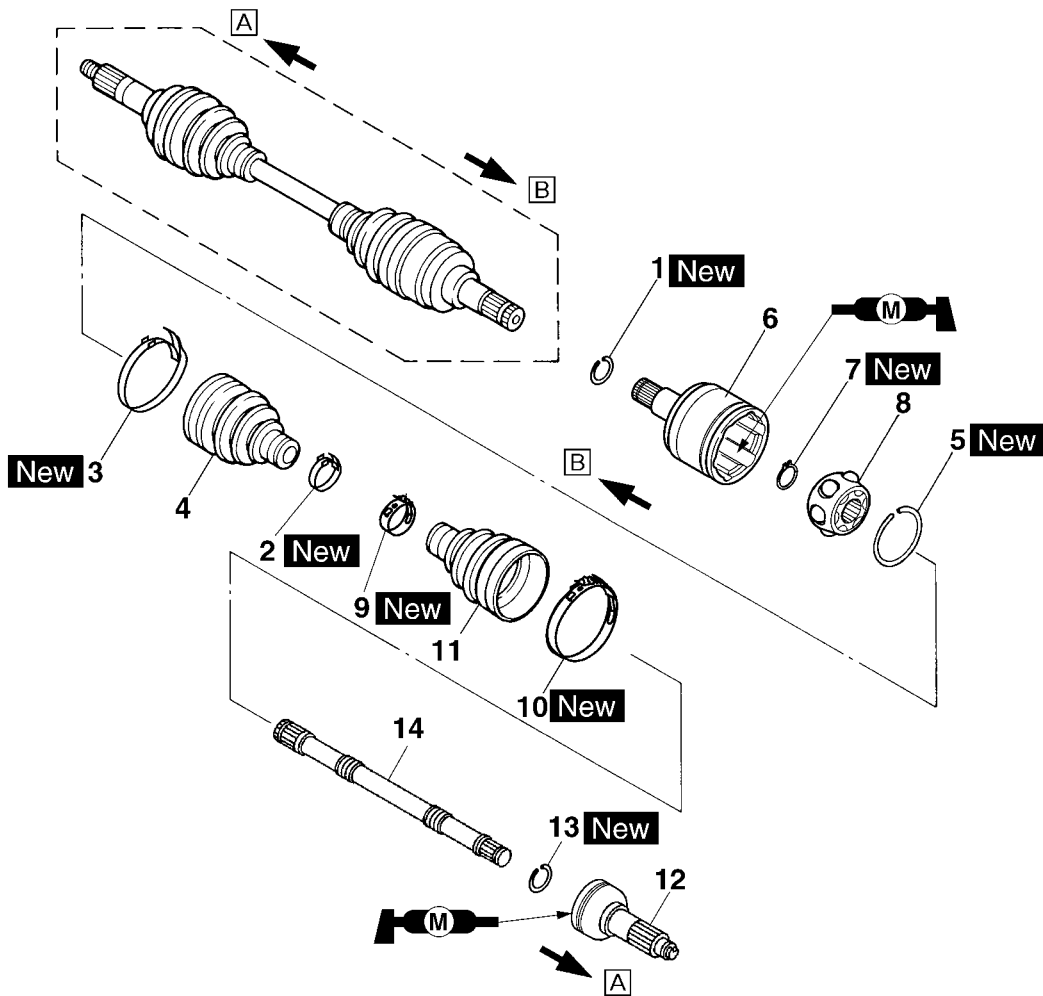

Order	Job/Parts to remove	Q'ty	Remarks
14	Constant velocity shaft	1	
			For assembly, reverse the disassembly procedure.

A: Wheel side
B: Differential side

FRONT CONSTANT VELOCITY SHAFT ASSEMBLIES, DIFFERENTIAL ASSEMBLY AND FRONT DRIVE SHAFT

Disassembling the differential assembly

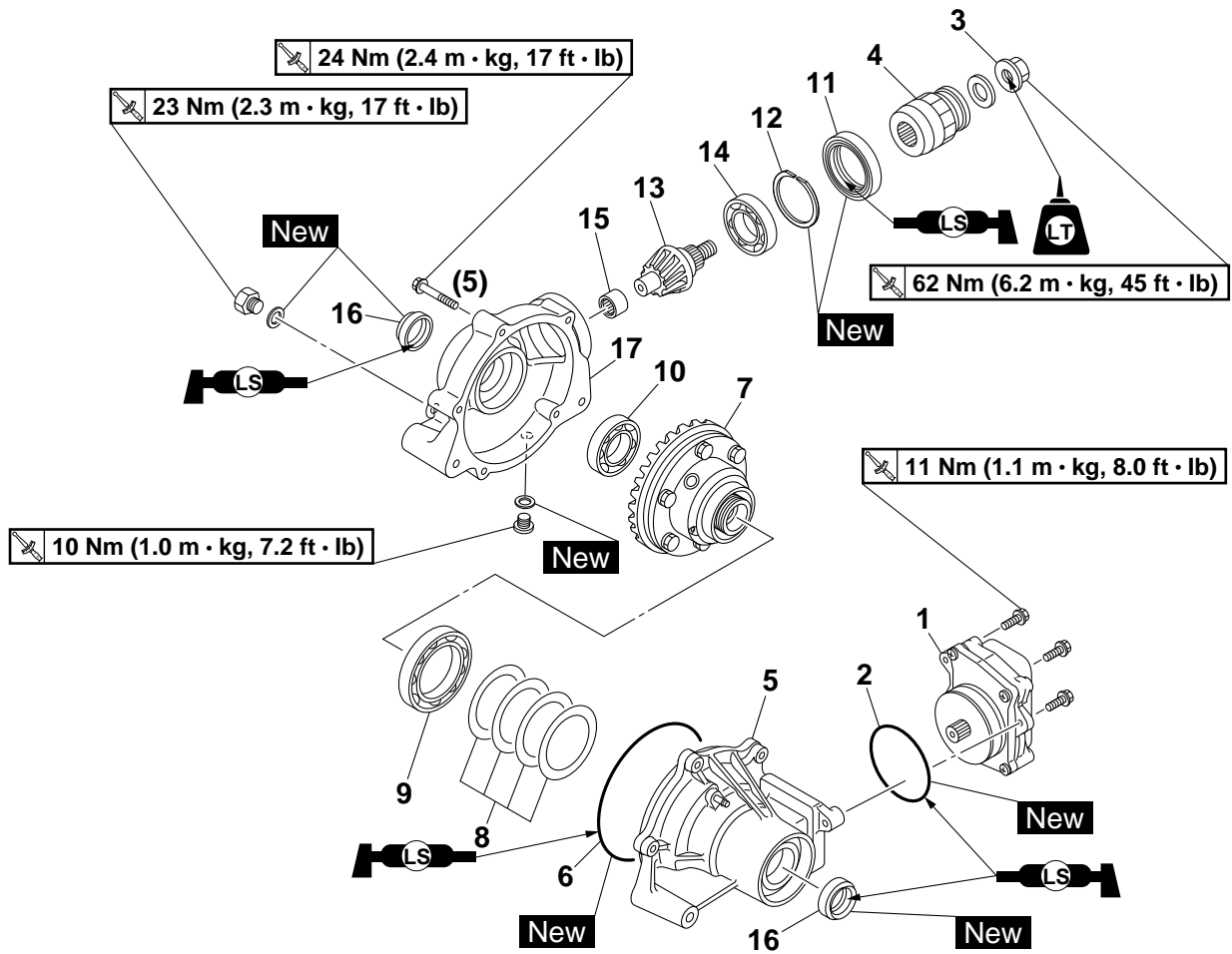

Order	Job/Parts to remove	Q'ty	Remarks
			TIP Do not disassemble the differential motor or remove the differential motor pinion gear.
1	Differential motor	1	
2	O-ring	1	
3	Front drive shaft yoke nut (differential case side)	1	
4	Front drive shaft yoke (differential case side)	1	
5	Differential case cover	1	
6	O-ring	1	
7	Differential gear assembly	1	
8	Differential gear assembly shim		Refer to "ADJUSTING THE DIFFERENTIAL GEAR BACKLASH" on page 8-13.
9	Bearing	1	
10	Bearing	1	
11	Oil seal	1	
12	Clip	1	
13	Differential pinion gear	1	
14	Bearing	1	

FRONT CONSTANT VELOCITY SHAFT ASSEMBLIES, DIFFERENTIAL ASSEMBLY AND FRONT DRIVE SHAFT

Disassembling the differential assembly

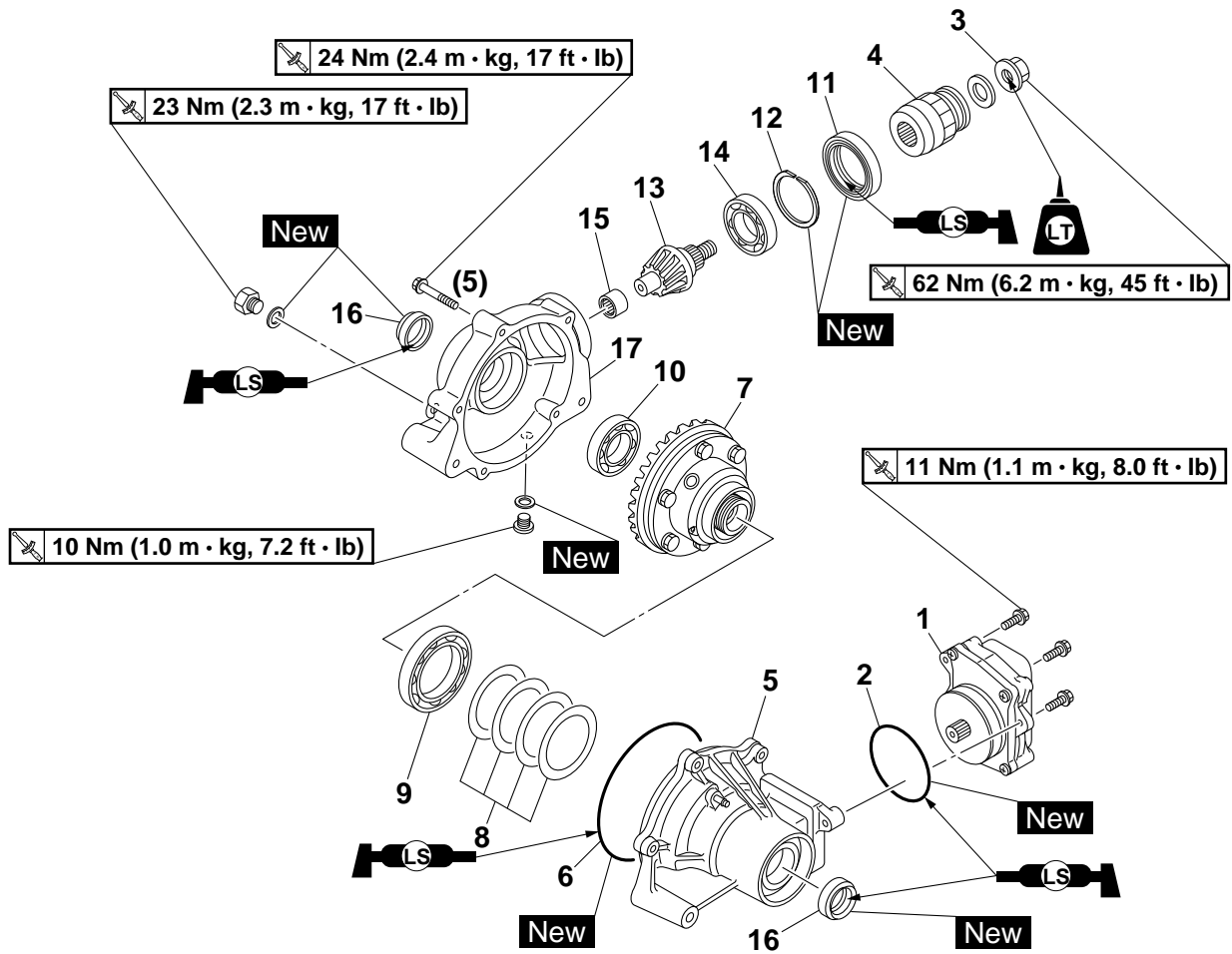

Order	Job/Parts to remove	Q'ty	Remarks
15	Bearing	1	
16	Oil seal	2	
17	Differential case	1	
			For assembly, reverse the disassembly procedure.

FRONT CONSTANT VELOCITY SHAFT ASSEMBLIES, DIFFERENTIAL ASSEMBLY AND FRONT DRIVE SHAFT

EAS29930

DISASSEMBLING THE FRONT CONSTANT VELOCITY SHAFT ASSEMBLIES

The following procedure applies to both of the front constant velocity shaft assemblies.

1. Remove:
 - Boot bands
 - Clip "1"
 - Double offset joint "2"
 - Circlip "3"
 - Ball bearing "4"
 - Dust boot "5"

TIP

Before removing the clip, slide the dust boot away from the double offset joint.

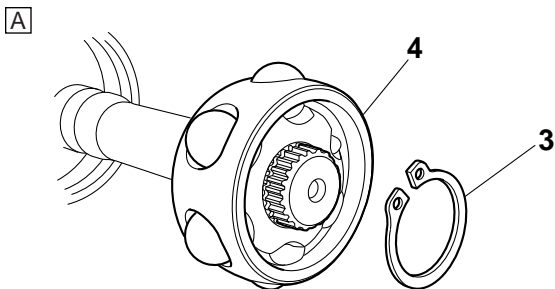
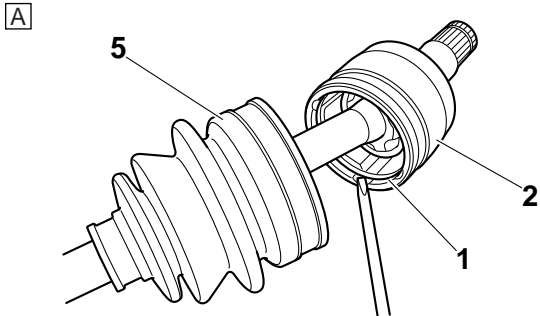

A. Differential side

2. Remove:
 - Boot band "1"
 Use the boot band installation tool "2".

	<p>Boots band installation tool 90890-01526 YM-01526</p>
---	---

B

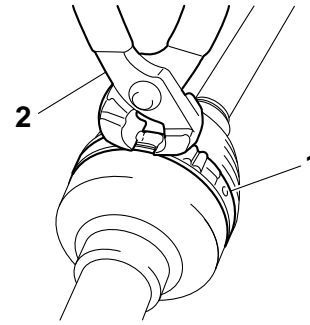

B. Wheel side

3. Remove:
 - Dust boot
 - Constant velocity joint
 - Clip

TIP

Secure the constant velocity shaft in a vise, and then remove the constant velocity joint using hammers.

B

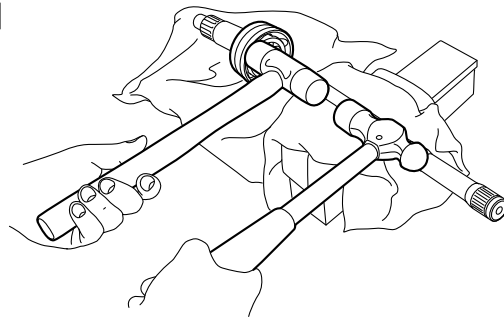

B. Wheel side

EAS29960

CHECKING THE FRONT CONSTANT VELOCITY SHAFT ASSEMBLIES

The following procedure applies to both of the front constant velocity shaft assemblies.

1. Check:
 - Double offset joint splines
 - Constant velocity joint splines
 - Constant velocity shaft splines
 Wear/damage → Replace.
2. Check:
 - Dust boots
 Cracks/damage → Replace.

ECA28P1042

NOTICE

Always use new boot bands.

3. Check:
 - Balls and ball races
 - Inner surface of double offset joint
 Pitting/wear/damage → Replace.

FRONT CONSTANT VELOCITY SHAFT ASSEMBLIES, DIFFERENTIAL ASSEMBLY AND FRONT DRIVE SHAFT

EAS29990

ASSEMBLING THE FRONT CONSTANT VELOCITY SHAFT ASSEMBLIES

The following procedure applies to both of the front constant velocity shaft assemblies.

1. Install:

- Clip "1" **New**
- Constant velocity joint "2"
- Constant velocity shaft "3"
- Dust boot



- Install the clip.
- Install the constant velocity joint.

TIP

- Install the clip into the groove in the constant velocity shaft as shown.
- Secure the constant velocity joint in a vise, and then fit the constant velocity shaft into the constant velocity joint using a hammer.

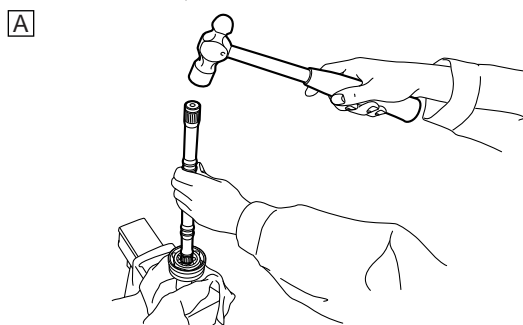
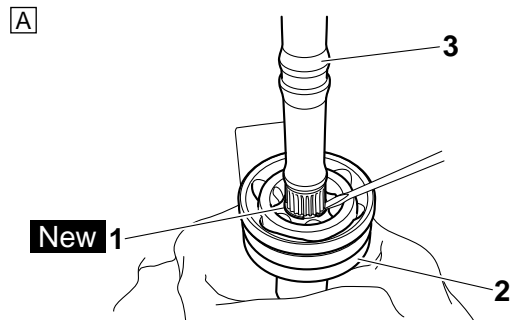
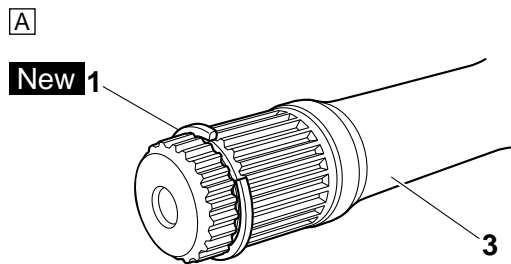

A. Wheel side



2. Install:

- Dust boot

- Ball bearing "1"
- Circlip "2" **New**
- Double offset joint "3"
- Clip "4" **New**

TIP

- Securely install the circlip into the groove in the constant velocity shaft.
- Securely install the clip into the groove in the double offset joint.

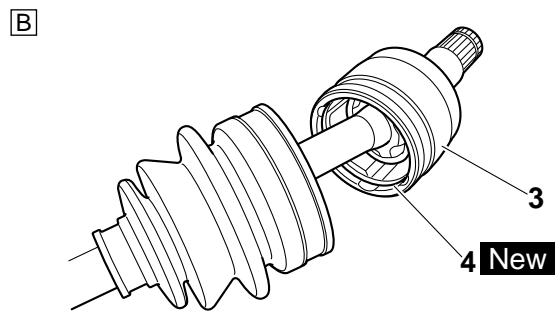
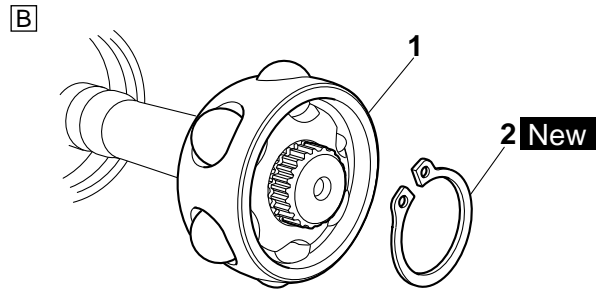

B. Differential side

3. Apply:

- Molybdenum disulfide grease (into the double offset joint, constant velocity joint, and dust boots)

	<p>Molybdenum disulfide grease 50 g (1.8 oz) per dust boot (wheel side) 65 g (2.3 oz) per dust boot (differential side)</p>
---	--

TIP

Molybdenum disulfide grease is included in the repair kit.

4. Install:

- Dust boots "1"
- Boot bands "2", "3", "4", "5" **New**

TIP

- The new boot bands may differ from the original ones.

FRONT CONSTANT VELOCITY SHAFT ASSEMBLIES, DIFFERENTIAL ASSEMBLY AND FRONT DRIVE SHAFT

b. Measure the differential gear backlash again.



REAR CONSTANT VELOCITY SHAFT ASSEMBLIES, FINAL DRIVE ASSEMBLY AND REAR DRIVE SHAFT

EAS30050

REAR CONSTANT VELOCITY SHAFT ASSEMBLIES, FINAL DRIVE ASSEMBLY AND REAR DRIVE SHAFT

Removing the rear constant velocity shaft assemblies, final drive assembly and rear drive shaft

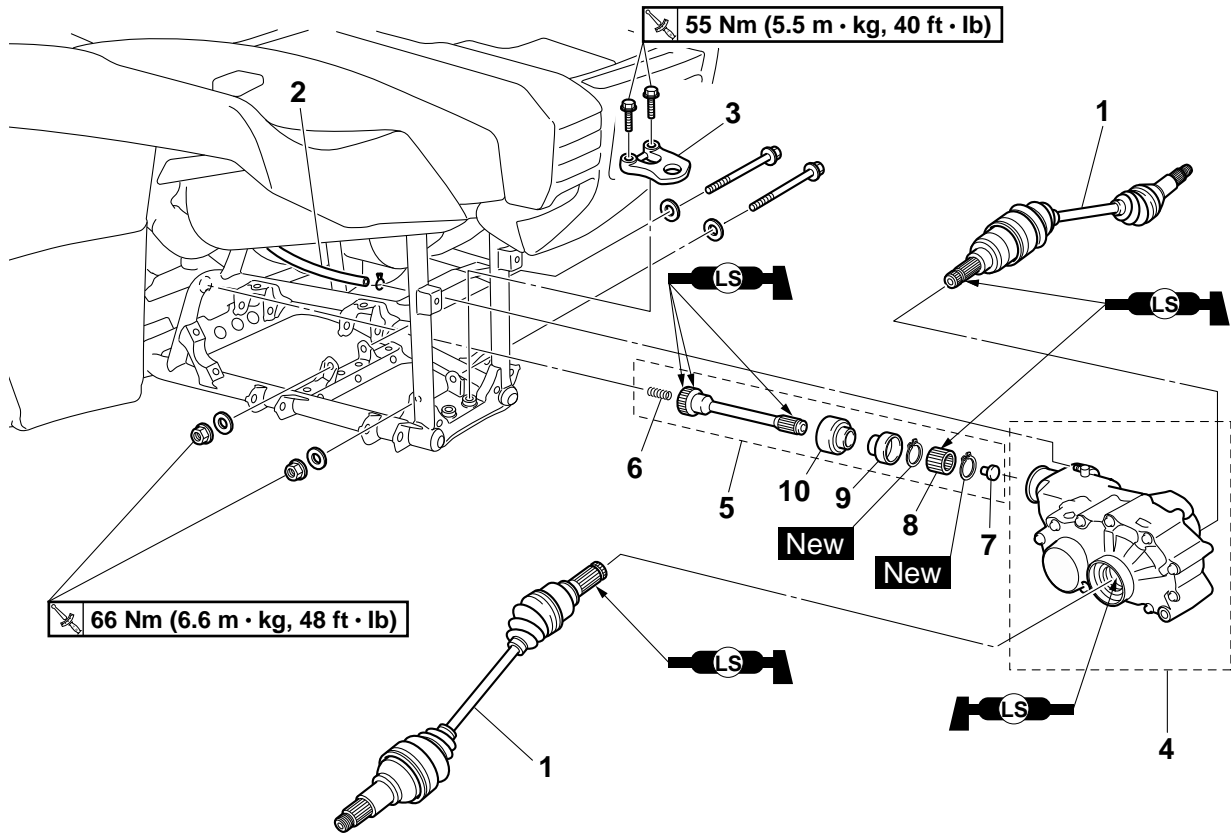

Order	Job/Parts to remove	Q'ty	Remarks
	Rear engine skid plate/Rear fender		Refer to "GENERAL CHASSIS" on page 4-1.
	Rear arms		Refer to "REAR ARMS AND REAR SHOCK ABSORBER ASSEMBLIES" on page 4-67.
	Final gear oil		Drain. Refer to "CHANGING THE FINAL GEAR OIL" on page 3-24.
1	Rear constant velocity shaft assembly	2	
2	Final drive case breather hose	1	Disconnect.
3	Trailer hitch	1	
4	Final drive assembly	1	
5	Rear drive shaft	1	
6	Spring	1	
7	Damper	1	
8	Rear drive shaft coupling sleeve	1	
9	Dust seal	1	

REAR CONSTANT VELOCITY SHAFT ASSEMBLIES, FINAL DRIVE ASSEMBLY AND REAR DRIVE SHAFT

Removing the rear constant velocity shaft assemblies, final drive assembly and rear drive shaft

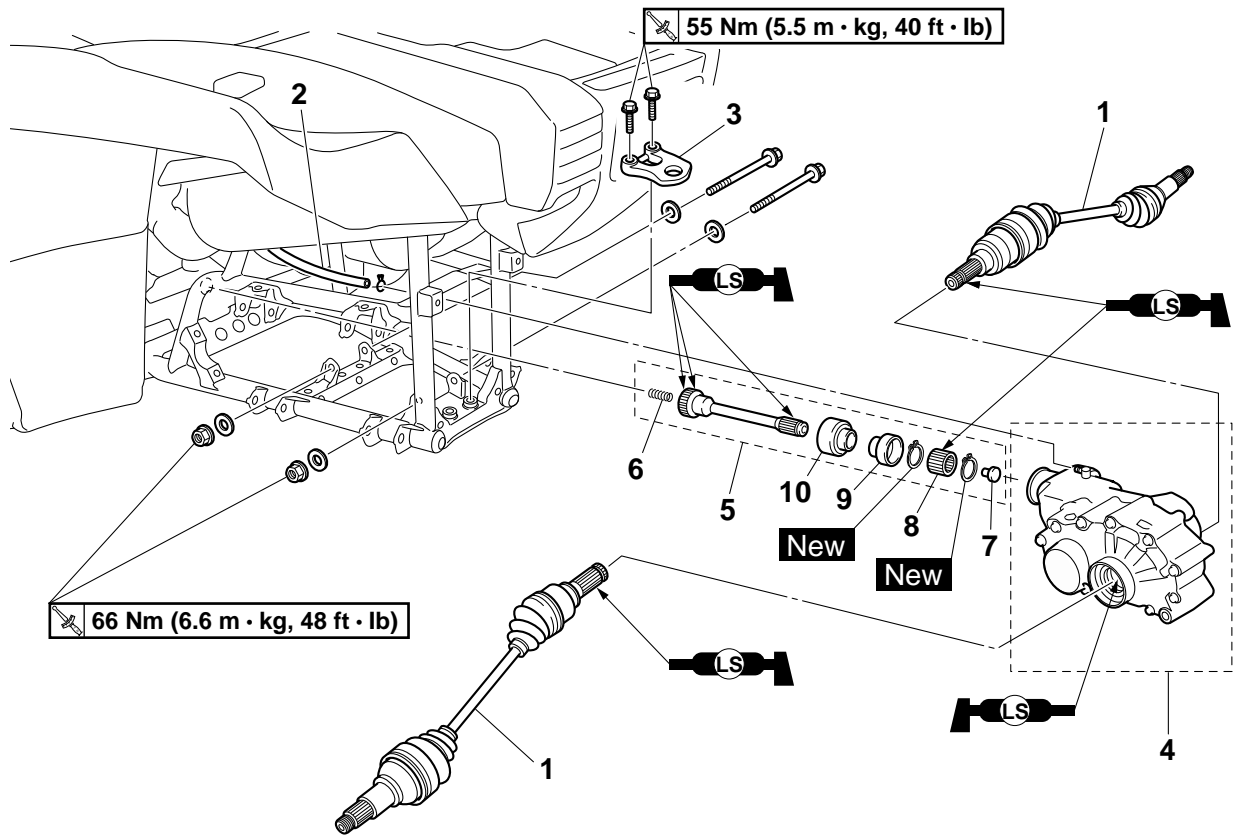

Order	Job/Parts to remove	Q'ty	Remarks
10	Dust seal	1	
			For installation, reverse the removal procedure.

REAR CONSTANT VELOCITY SHAFT ASSEMBLIES, FINAL DRIVE ASSEMBLY AND REAR DRIVE SHAFT

Disassembling the rear constant velocity shaft assemblies

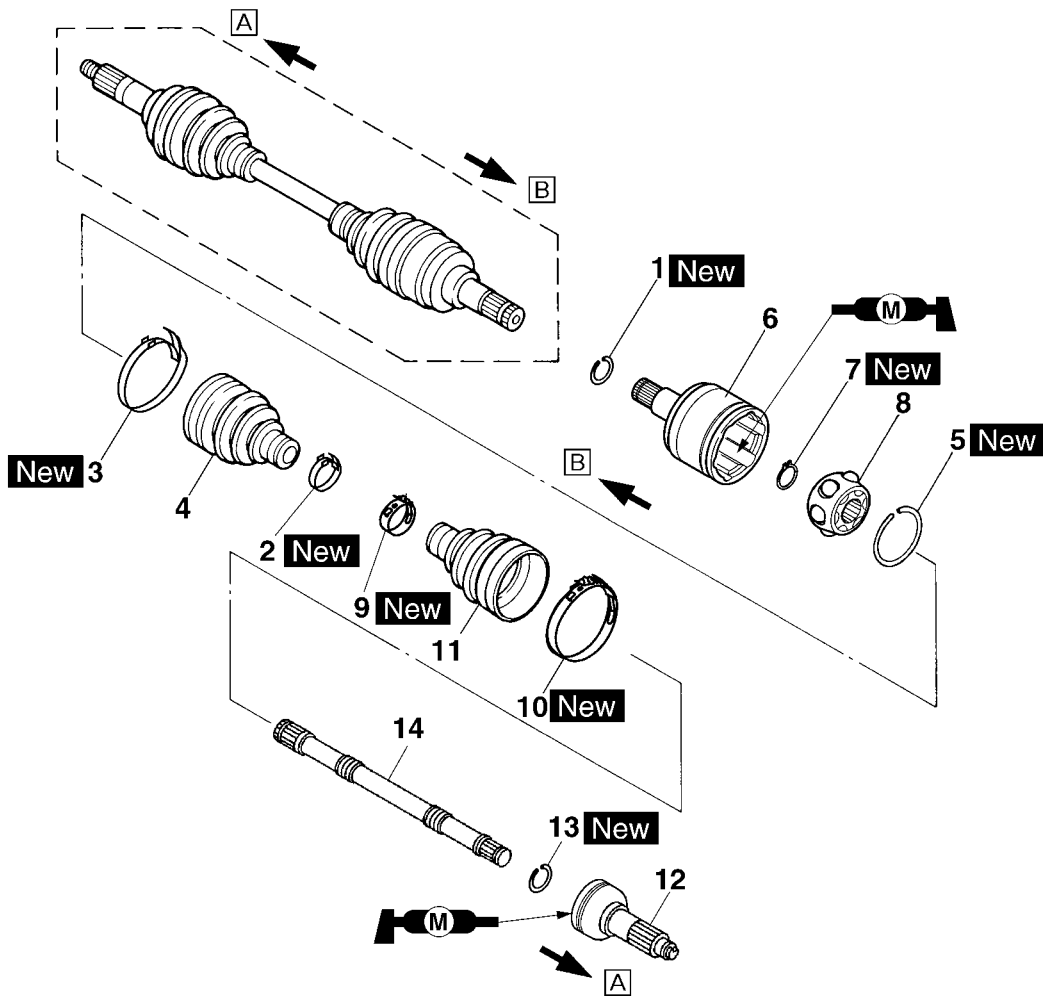

Order	Job/Parts to remove	Q'ty	Remarks
			The following procedure applies to both of the rear constant velocity shaft assemblies.
1	Clip	1	
2	Boot band	1	
3	Boot band	1	
4	Dust boot	1	
5	Clip	1	
6	Double offset joint	1	
7	Circlip	1	
8	Ball bearing	1	
9	Boot band	1	
10	Boot band	1	
11	Dust boot	1	
12	Constant velocity joint	1	
13	Clip	1	

REAR CONSTANT VELOCITY SHAFT ASSEMBLIES, FINAL DRIVE ASSEMBLY AND REAR DRIVE SHAFT

Disassembling the rear constant velocity shaft assemblies

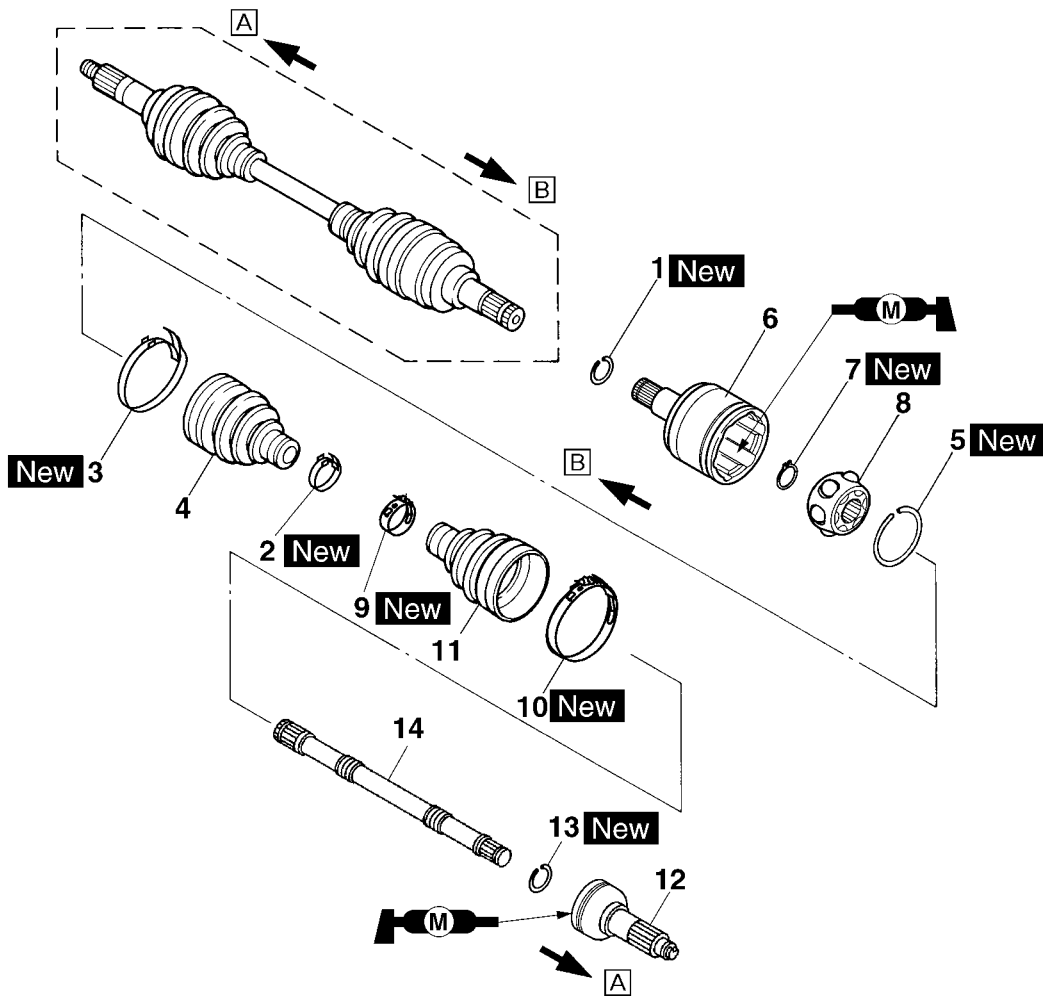

Order	Job/Parts to remove	Q'ty	Remarks
14	Constant velocity shaft	1	
			For assembly, reverse the disassembly procedure.

A: Wheel side
 B: Final drive side

REAR CONSTANT VELOCITY SHAFT ASSEMBLIES, FINAL DRIVE ASSEMBLY AND REAR DRIVE SHAFT

Disassembling the final drive assembly

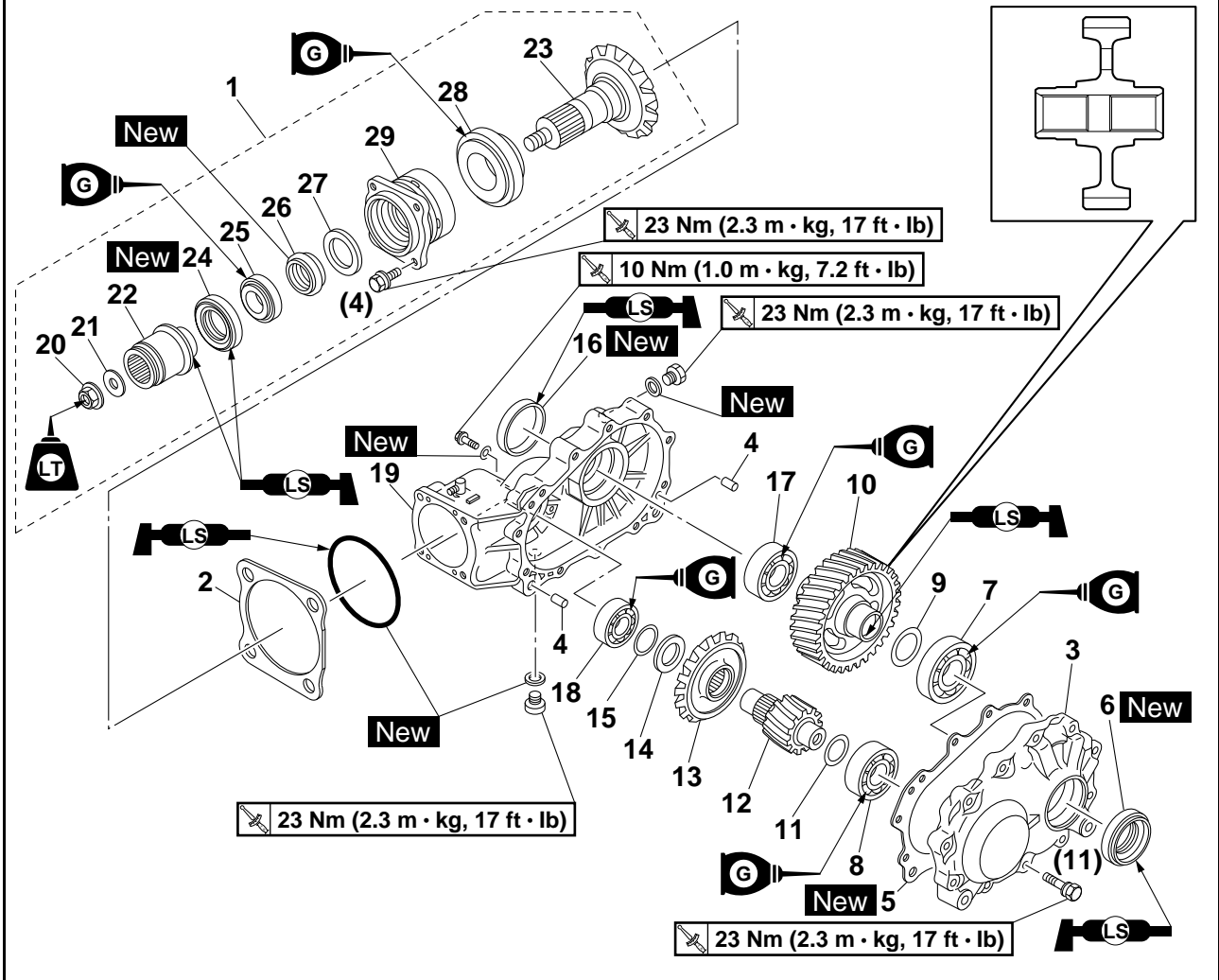

Order	Job/Parts to remove	Q'ty	Remarks
1	Final drive pinion gear assembly	1	
2	Final drive pinion gear shim		Refer to "SELECTING THE FINAL DRIVE PINION GEAR SHIM(S)" on page 8-25.
3	Final drive case cover	1	TIP Working in a crisscross pattern, loosen each bolt 1/4 of a turn. After all the bolts are loosened, remove them.
4	Dowel pin	2	
5	Gasket	1	
6	Oil seal	1	
7	Bearing	1	
8	Bearing	1	
9	Wheel gear shim		Refer to "SELECTING THE WHEEL GEAR SHIM(S)" on page 8-29.
10	Wheel gear	1	
11	Final driven pinion gear shim (final drive case cover side)		Refer to "SELECTING THE FINAL DRIVEN PINION GEAR SHIM (FINAL DRIVE CASE COVER SIDE)" on page 8-28.
12	Pinion gear	1	

REAR CONSTANT VELOCITY SHAFT ASSEMBLIES, FINAL DRIVE ASSEMBLY AND REAR DRIVE SHAFT

Disassembling the final drive assembly

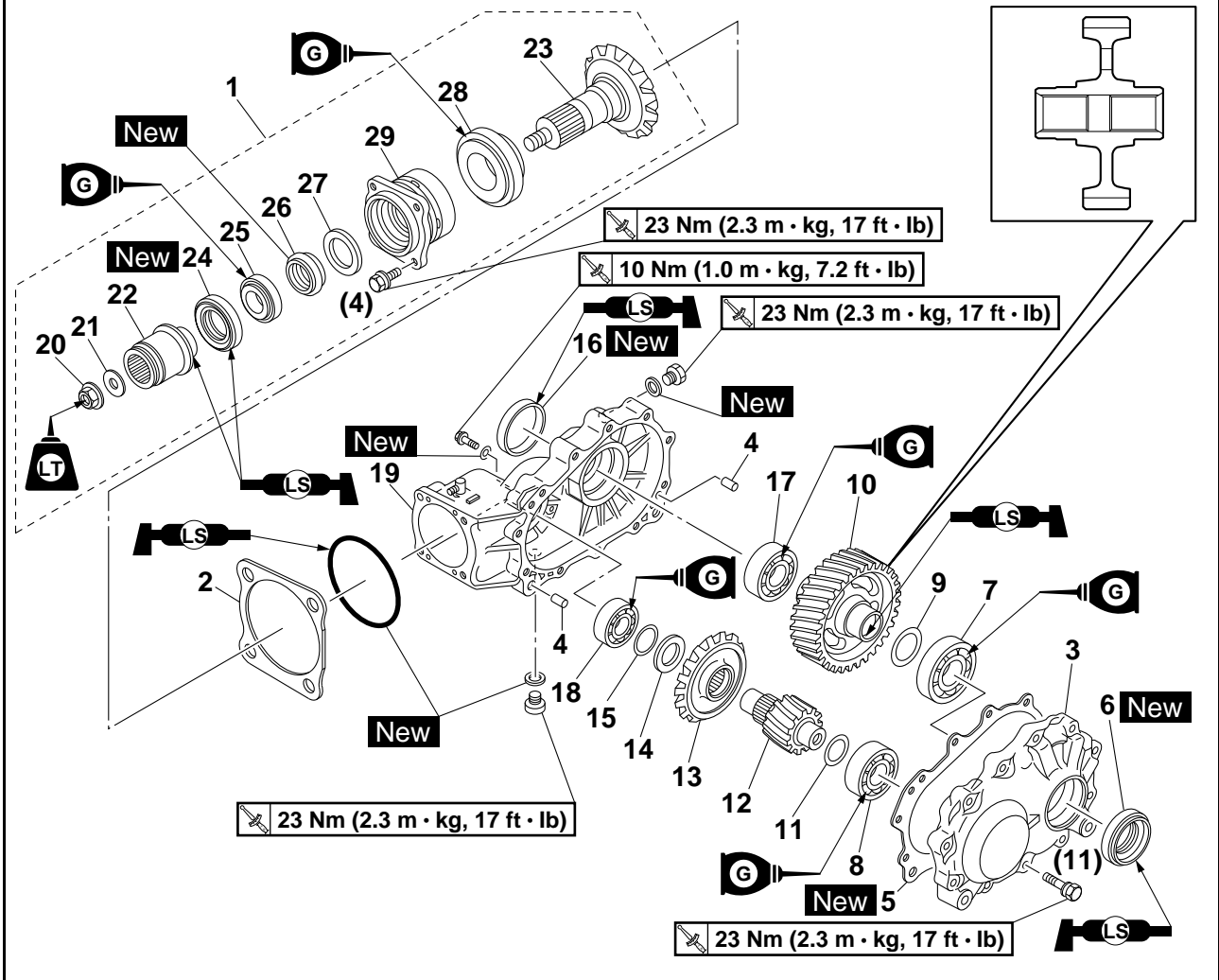

Order	Job/Parts to remove	Q'ty	Remarks
13	Final driven pinion gear	1	
14	Thrust washer		Refer to "SELECTING THE FINAL DRIVEN PINION GEAR SHIM (FINAL DRIVE CASE SIDE) AND THRUST WASHER" on page 8-26.
15	Final driven pinion gear shim (final drive case side)		Refer to "SELECTING THE FINAL DRIVEN PINION GEAR SHIM (FINAL DRIVE CASE SIDE) AND THRUST WASHER" on page 8-26.
16	Oil seal	1	
17	Bearing	1	
18	Bearing	1	
19	Final drive case	1	
20	Rear drive shaft yoke nut (final drive case side)	1	
21	Washer	1	
22	Rear drive shaft yoke (final drive case side)	1	
23	Final drive pinion gear	1	
24	Oil seal	1	
25	Bearing	1	
26	Expander	1	

REAR CONSTANT VELOCITY SHAFT ASSEMBLIES, FINAL DRIVE ASSEMBLY AND REAR DRIVE SHAFT

Disassembling the final drive assembly

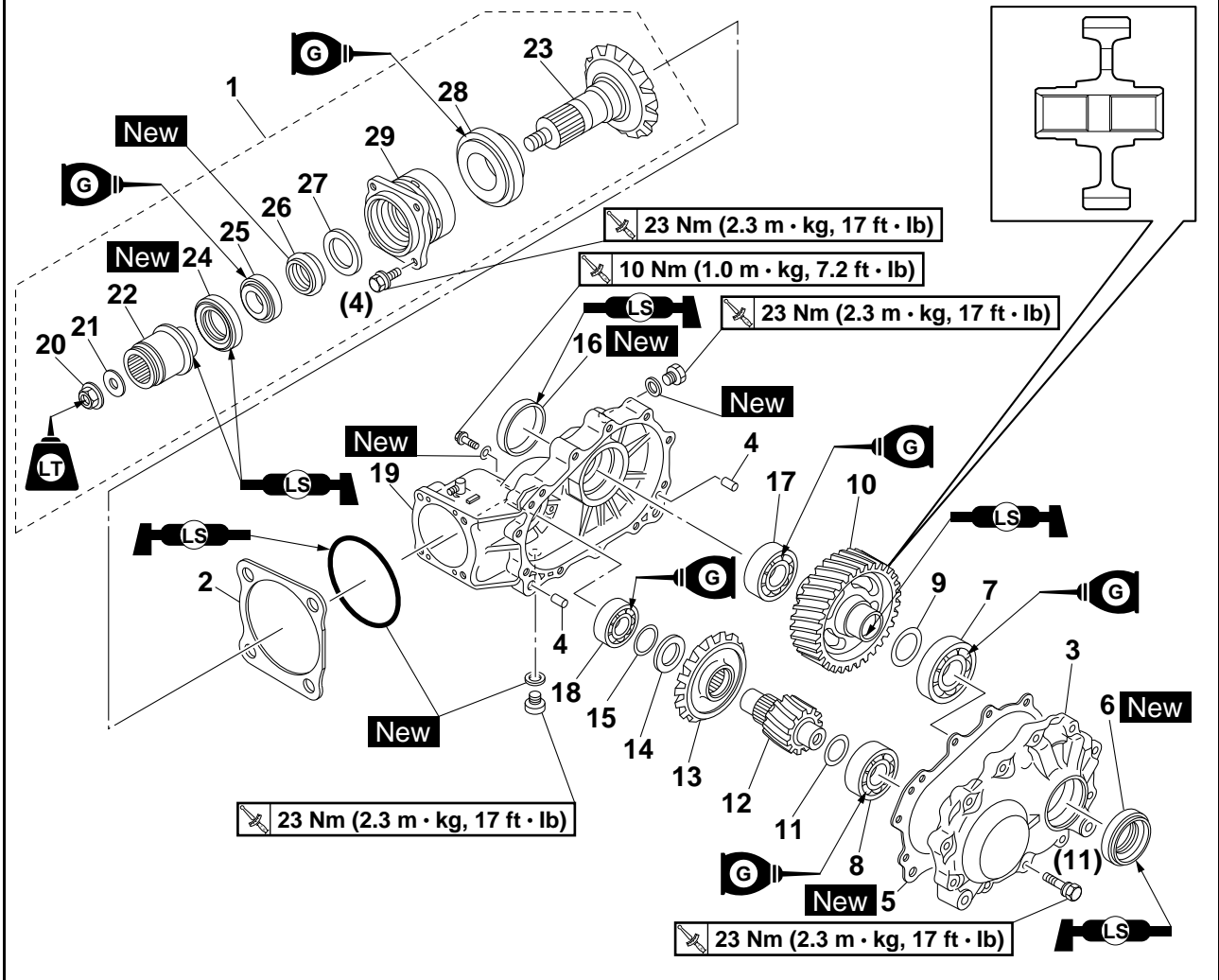

Order	Job/Parts to remove	Q'ty	Remarks
27	Washer	1	
28	Bearing	1	
29	Final drive pinion gear bearing housing	1	
			For assembly, reverse the disassembly procedure.

REAR CONSTANT VELOCITY SHAFT ASSEMBLIES, FINAL DRIVE ASSEMBLY AND REAR DRIVE SHAFT

EAS30060

DISASSEMBLING THE REAR CONSTANT VELOCITY SHAFT ASSEMBLIES

The following procedure applies to both of the rear constant velocity shaft assemblies.

- Remove:
 - Boot bands
 - Clip "1"
 - Double offset joint "2"
 - Circlip "3"
 - Ball bearing "4"
 - Dust boot "5"

TIP

Before removing the clip, slide the dust boot away from the double offset joint.

A

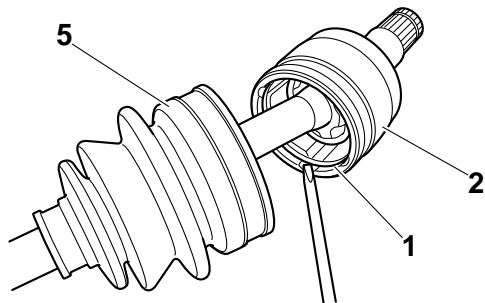

A

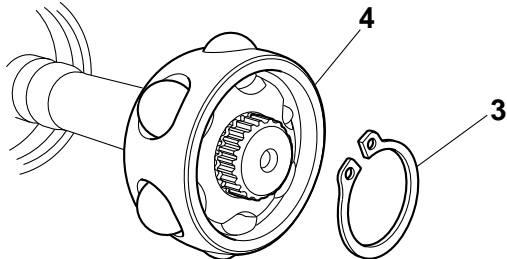

A. Final drive side

- Remove:
 - Boot band "1"
 Use the boot band installation tool "2".



Boots band installation tool
90890-01526
YM-01526

B

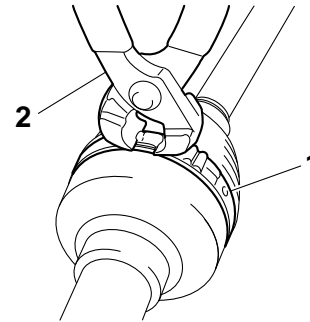

B. Wheel side

- Remove:
 - Dust boot
 - Constant velocity joint
 - Clip

TIP

Secure the constant velocity shaft in a vise, and then remove the constant velocity joint using hammers.

B

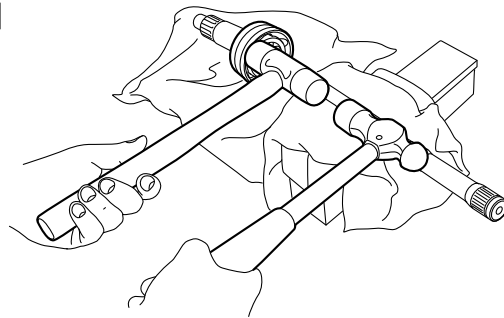

B. Wheel side

EAS30330

CHECKING THE REAR CONSTANT VELOCITY SHAFT ASSEMBLIES

The following procedure applies to both of the rear constant velocity shaft assemblies.

- Check:
 - Double offset joint splines
 - Constant velocity joint splines
 - Constant velocity shaft splines
 Wear/damage → Replace.
- Check:
 - Dust boots
 Cracks/damage → Replace.

ECA16210

NOTICE

Always use a new boot band.

- Check:
 - Balls and ball races
 - Inner surface of double offset joint
 Pitting/wear/damage → Replace.

REAR CONSTANT VELOCITY SHAFT ASSEMBLIES, FINAL DRIVE ASSEMBLY AND REAR DRIVE SHAFT

EAS30070

ASSEMBLING THE REAR CONSTANT VELOCITY SHAFT ASSEMBLIES

The following procedure applies to both of the rear constant velocity shaft assemblies.

1. Install:

- Clip "1" **New**
- Constant velocity joint "2"
- Constant velocity shaft "3"
- Dust boot



- Install the clip.
- Install the constant velocity joint.

TIP

- Install the clip into the groove in the constant velocity shaft as shown.
- Secure the constant velocity joint in a vise, and then fit the constant velocity shaft into the constant velocity joint using a hammer.

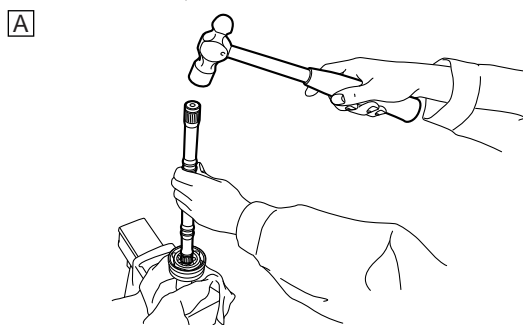
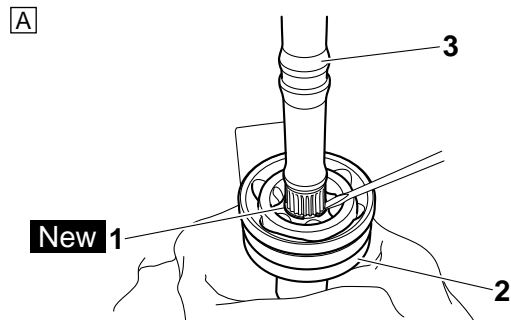
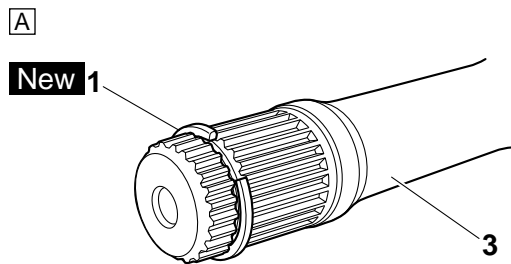

A. Wheel side



2. Install:

- Dust boot

- Ball bearing "1"
- Circlip "2" **New**
- Double offset joint "3"
- Clip "4" **New**

TIP

- Securely install the circlip into the groove in the constant velocity shaft.
- Securely install the clip into the groove in the double offset joint.

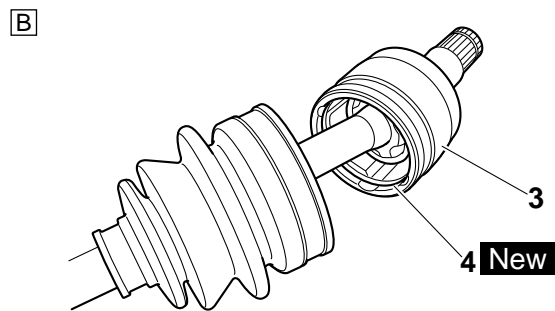
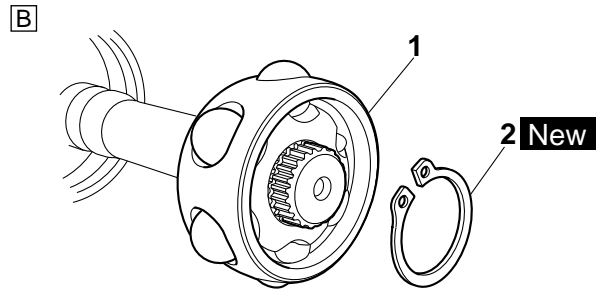

B. Final drive side

3. Apply:

- Molybdenum disulfide grease
(into the double offset joint, constant velocity joint, and dust boots)

	<p>Molybdenum disulfide grease 50 g (1.8 oz) per dust boot (wheel side) 70 g (2.5 oz) per dust boot (final drive side)</p>
---	---

TIP

Molybdenum disulfide grease is included in the repair kit.

4. Install:

- Dust boots "1"
- Boot bands "2", "3", "4", "5" **New**

TIP

- The new boot bands may differ from the original ones.

REAR CONSTANT VELOCITY SHAFT ASSEMBLIES, FINAL DRIVE ASSEMBLY AND REAR DRIVE SHAFT

EAS28P1019

ASSEMBLING THE FINAL DRIVE CASE

1. Install:
 - Oil seals "1"

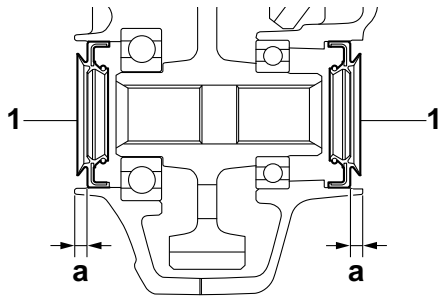
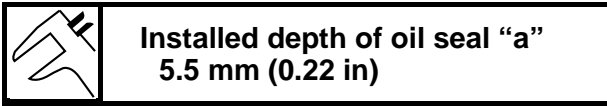

EAS28P1020

ASSEMBLING THE FINAL DRIVE PINION GEAR ASSEMBLY

1. Install:
 - Rear drive shaft yoke nut "1"

- a. Place a folded rag as shown.
- b. Secure the final drive pinion gear in the vise.

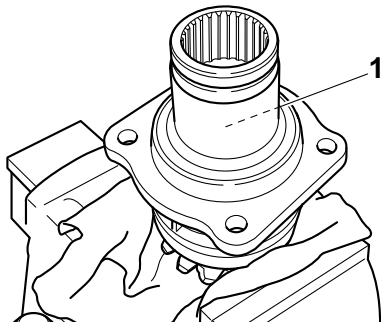

- c. Tighten the rear drive shaft yoke nut. (temporarily)

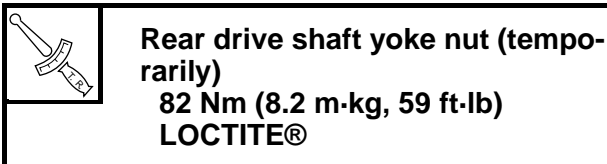

- d. Secure the final drive pinion gear bearing housing in a vice, and then turn the nut with a torque wrench to check the starting torque.

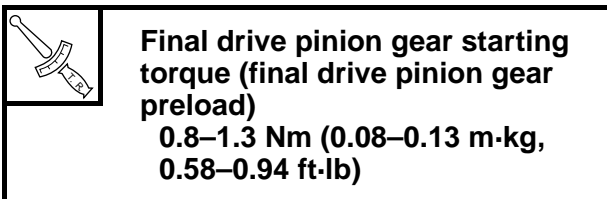

- e. Out of specification → Tighten the nut further.

- f. Repeat steps (d) and (e) until the starting torque is within specification.

TIP

- Be careful not to exceed the specified starting torque.
- If the specified starting torque is exceeded, replace the expander with a new one and reassemble the final drive pinion gear assembly.
- Make sure that the distance "a" is 67.5–68.1 mm (2.66–2.68 in) as shown.

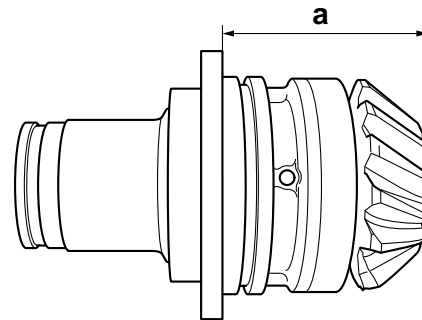

2. Check:
 - Final drive assembly operation
Unsmooth operation → Replace the final drive assembly.
Insert the double offset joint into the final drive assembly, and turn the gears back and forth.

EAS30110

SELECTING THE FINAL DRIVE PINION GEAR SHIM(S)

1. Select:
 - Final drive pinion gear shim(s) "1"

- a. To find the final drive pinion gear shim thickness "A", use the following formula.

$$\text{Final drive pinion gear shim thickness "A"} = \text{"a"} + (\text{"c"} - \text{"b"}) - \text{"d"}$$

"a" = 55 mm

"b" = a numeral (usually a decimal number) on the final drive pinion gear either added to or subtracted from "22.2"

"c" = a numeral (usually a decimal number) on the final drive pinion gear bearing housing either added to or subtracted from "67.8"

"d" = a numeral (usually a decimal number) on the final drive case either added to or subtracted from "100"

REAR CONSTANT VELOCITY SHAFT ASSEMBLIES, FINAL DRIVE ASSEMBLY AND REAR DRIVE SHAFT

If "-01" is stamped on the final drive case,
 "d" = 100 - 0.01
 = 99.99

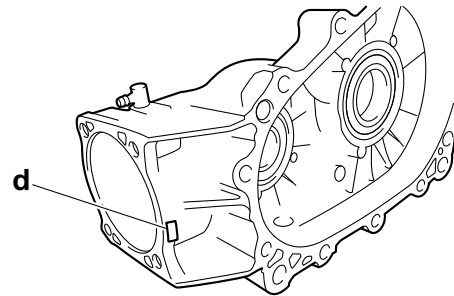
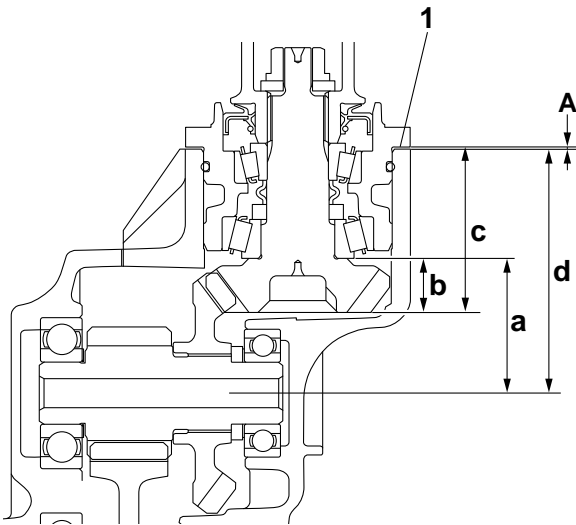

Therefore, "A" is 0.58.
 "A" = 55 + (67.75 - 22.18) - 99.99
 = 0.58

Round off the hundredth digit and select the appropriate shim(s).

In the example above, the calculated number is 0.58. The chart instructs you to round off 8 to 10 at the hundredth place. Thus, the shim thickness is 0.60 mm (0.024 in).

Example:

"a" = 55
 If "-02" is stamped on the final drive pinion gear,
 "b" = 22.2 - 0.02
 = 22.18

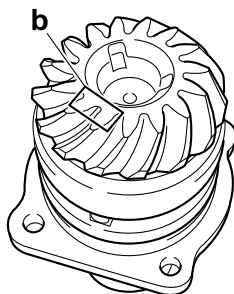

Hundredth	Rounded value
0, 1, 2	0
3, 4, 5, 6, 7	5
8, 9	10

Shims are supplied in the following thicknesses.

	Final drive pinion gear shims
	Thickness (mm) 0.25 0.30 0.35 0.40 0.45 0.50

If "-05" is stamped on the final drive pinion gear bearing housing,
 "c" = 67.8 - 0.05
 = 67.75

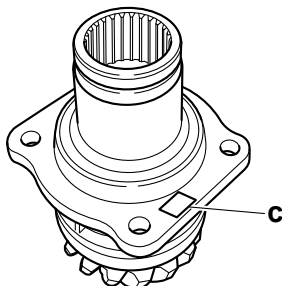

EAS30120

SELECTING THE FINAL DRIVEN PINION GEAR SHIM (FINAL DRIVE CASE SIDE) AND THRUST WASHER

- Select:
 - Final driven pinion gear shim (final drive case side) "1"
 - Thrust washer "2"



- To find the final driven pinion gear shim (final drive case side) and thrust washer thickness "B", use the following formula.

Final driven pinion gear shim (final drive case side) and thrust washer thickness "B" = "h" - ("e" - "f" + "g")
--

REAR CONSTANT VELOCITY SHAFT ASSEMBLIES, FINAL DRIVE ASSEMBLY AND REAR DRIVE SHAFT

“e” = a numeral (usually a decimal number) on the final drive case either added to or subtracted from “71.6”

“f” = a numeral (usually a decimal number) on the final driven pinion gear either added to or subtracted from “51.0”

“g” = a numeral (usually a decimal number) on the final driven pinion gear either added to or subtracted from “24.0”

“h” = 49.8

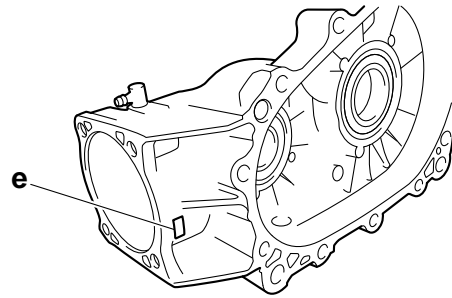

If “-12” is stamped on the outside of the final driven pinion gear,

$$\begin{aligned} \text{“f”} &= 51.0 - 0.12 \\ &= 50.88 \end{aligned}$$

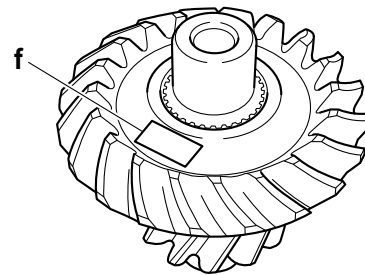

If “-05” is stamped on the outside of the final driven pinion gear,

$$\begin{aligned} \text{“g”} &= 24.0 - 0.05 \\ &= 23.95 \end{aligned}$$

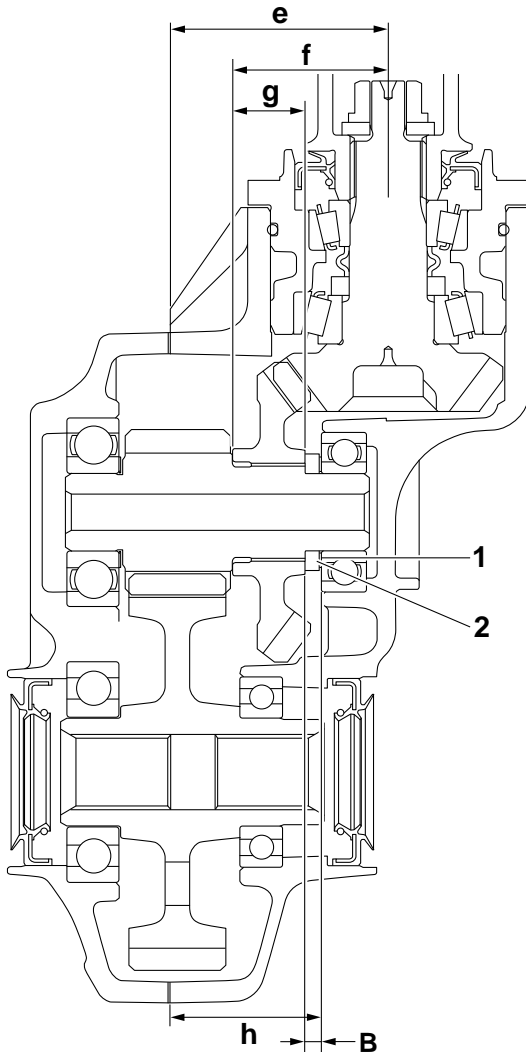
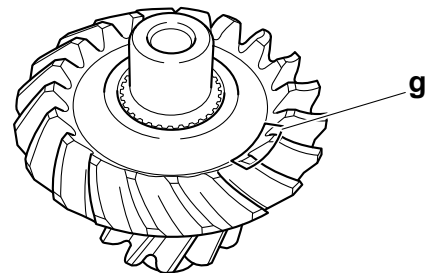

Example:

If “-03” is stamped on the final drive case,

$$\begin{aligned} \text{“e”} &= 71.6 - 0.03 \\ &= 71.57 \end{aligned}$$

“h” = 49.8

Therefore, shim and thrust washer thickness “B” is 5.16.

$$\begin{aligned} \text{“B”} &= 49.8 - (71.57 - 50.88 + 23.95) \\ &= 5.16 \end{aligned}$$

Round off the hundredth digit and select the appropriate shim(s).

In the example above, the calculated number is 5.16. The chart instructs you to round off 6 to 5 at the hundredth place.

Thus, the shim and thrust washer thickness is 5.15 mm.

REAR CONSTANT VELOCITY SHAFT ASSEMBLIES, FINAL DRIVE ASSEMBLY AND REAR DRIVE SHAFT

TIP

Measure the thickness of the originally fitted shim(s), and then calculate the required new shim thickness to bring the final driven pinion gear thrust clearance within the specified limits.

- b. Repeat the measurement steps until the final driven pinion gear thrust clearance is within the specified limits.



EAS28P1018

SELECTING THE WHEEL GEAR SHIM(S)

1. Measure:

- Wheel gear thrust clearance “D”

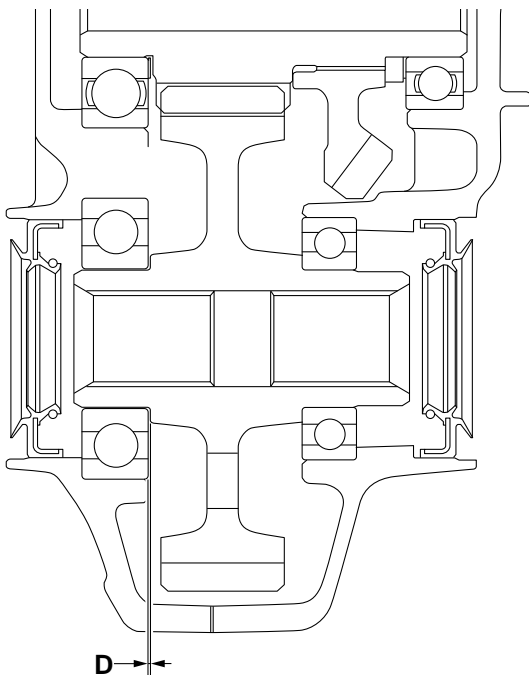

- a. Place four pieces of Plastigauge® between the originally fitted wheel gear shim(s) and the wheel gear.
- b. Install the wheel gear and tighten the bolts to specification.

	Final gear case cover bolt 23 Nm (2.3 m·kg, 17 ft·lb)
---	--

TIP

Do not turn the drive pinion gear, wheel gear, or driven pinion gear when measuring the clearance with Plastigauge®.

- c. Remove the wheel gear.
- d. Measure the thrust clearance. Calculate the width of the flattened Plastigauge® “1”.

	Wheel gear thrust clearance 0.03–0.07 mm (0.0012–0.0028 in)
---	--

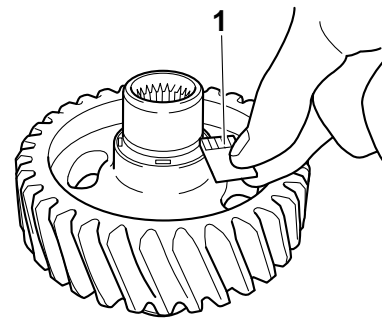

- e. If out of specification, remove the originally fitted shim(s), and then select the correct shim(s).



2. Select:
 - Wheel gear shim(s)



- a. Select suitable wheel gear shims using the following chart.

	Wheel gear shims Thickness (mm) 0.25 0.30 0.35 0.40 0.45 0.50
---	--

TIP

Measure the thickness of the originally fitted shim(s), and then calculate the required new shim thickness to bring the wheel gear thrust clearance within the specified limits.

- b. Repeat the measurement steps until the wheel gear thrust clearance is within the specified limits.



EAS30170

MEASURING THE FINAL GEAR BACKLASH

1. Secure the final drive case in a vise or another supporting device.
2. Remove:
 - Drain plug
 - Gasket
3. Install:
 - Ring gear fix bolt (M14) “1” (into the drain plug hole)

	Ring gear fix bolt (M14) 90890-01524 YM-01524
---	--

REAR CONSTANT VELOCITY SHAFT ASSEMBLIES, FINAL DRIVE ASSEMBLY AND REAR DRIVE SHAFT



Final driven pinion gear shims (final drive case cover side) "4"
Thickness (mm)
0.25 0.30 0.35 0.40 0.45 0.50



ELECTRICAL SYSTEM

IGNITION SYSTEM	9-1
CIRCUIT DIAGRAM	9-1
TROUBLESHOOTING	9-3
ELECTRIC STARTING SYSTEM	9-5
CIRCUIT DIAGRAM	9-5
STARTING CIRCUIT CUT-OFF SYSTEM OPERATION	9-7
TROUBLESHOOTING	9-8
CHARGING SYSTEM	9-11
CIRCUIT DIAGRAM	9-11
TROUBLESHOOTING	9-13
LIGHTING SYSTEM	9-15
CIRCUIT DIAGRAM	9-15
TROUBLESHOOTING	9-17
SIGNALING SYSTEM	9-19
CIRCUIT DIAGRAM (for CDN)	9-19
CIRCUIT DIAGRAM (for Europe and Oceania)	9-21
TROUBLESHOOTING	9-23
COOLING SYSTEM	9-29
CIRCUIT DIAGRAM	9-29
TROUBLESHOOTING	9-31
FUEL INJECTION SYSTEM	9-33
CIRCUIT DIAGRAM	9-33
ECU SELF-DIAGNOSTIC FUNCTION	9-35
SELF-DIAGNOSTIC FUNCTION TABLE	9-35
TROUBLESHOOTING METHOD	9-37
YAMAHA DIAGNOSTIC TOOL	9-38
TROUBLESHOOTING DETAILS	9-43
FUEL PUMP SYSTEM	9-57
CIRCUIT DIAGRAM	9-57
TROUBLESHOOTING	9-59
2WD/4WD SELECTING SYSTEM	9-61
CIRCUIT DIAGRAM	9-61
TROUBLESHOOTING	9-63

EPS (ELECTRIC POWER STEERING) SYSTEM (for EPS models)	9-65
CIRCUIT DIAGRAM	9-65
EPS CONTROL UNIT'S SELF-DIAGNOSTIC FUNCTION	9-67
EPS WARNING LIGHT DURING NORMAL OPERATION.....	9-67
DIAGNOSTIC MODE	9-68
SELF-DIAGNOSTIC FUNCTION TABLE (EPS SYSTEM).....	9-70
TROUBLESHOOTING DETAILS (EPS SYSTEM).....	9-71
ELECTRICAL COMPONENTS	9-75
CHECKING THE SWITCHES	9-79
CHECKING THE BULBS AND BULB SOCKETS	9-82
CHECKING THE FUSES	9-83
CHECKING AND CHARGING THE BATTERY	9-84
CHECKING THE RELAYS	9-87
CHECKING THE DIODE	9-89
CHECKING THE SPARK PLUG CAP	9-90
CHECKING THE IGNITION COIL	9-90
CHECKING THE IGNITION SPARK GAP.....	9-91
CHECKING THE CRANKSHAFT POSITION SENSOR.....	9-91
CHECKING THE LEAN ANGLE SENSOR.....	9-91
CHECKING THE STARTER MOTOR OPERATION	9-92
CHECKING THE STATOR COIL	9-92
CHECKING THE RECTIFIER/REGULATOR	9-93
CHECKING THE FUEL SENDER	9-93
CHECKING THE SPEED SENSOR	9-94
CHECKING THE RADIATOR FAN MOTOR	9-94
CHECKING THE RADIATOR FAN MOTOR CIRCUIT BREAKER	9-94
CHECKING THE COOLANT TEMPERATURE SENSOR.....	9-95
CHECKING THE THROTTLE POSITION SENSOR	9-95
CHECKING THE AIR INDUCTION SYSTEM SOLENOID	9-96
CHECKING THE INTAKE AIR PRESSURE SENSOR	9-96
CHECKING THE INTAKE AIR TEMPERATURE SENSOR	9-97
CHECKING THE EPS MOTOR (for EPS models)	9-97
CHECKING THE EPS TORQUE SENSOR (for EPS models)	9-98

EAS27090

IGNITION SYSTEM

EAS27100

CIRCUIT DIAGRAM

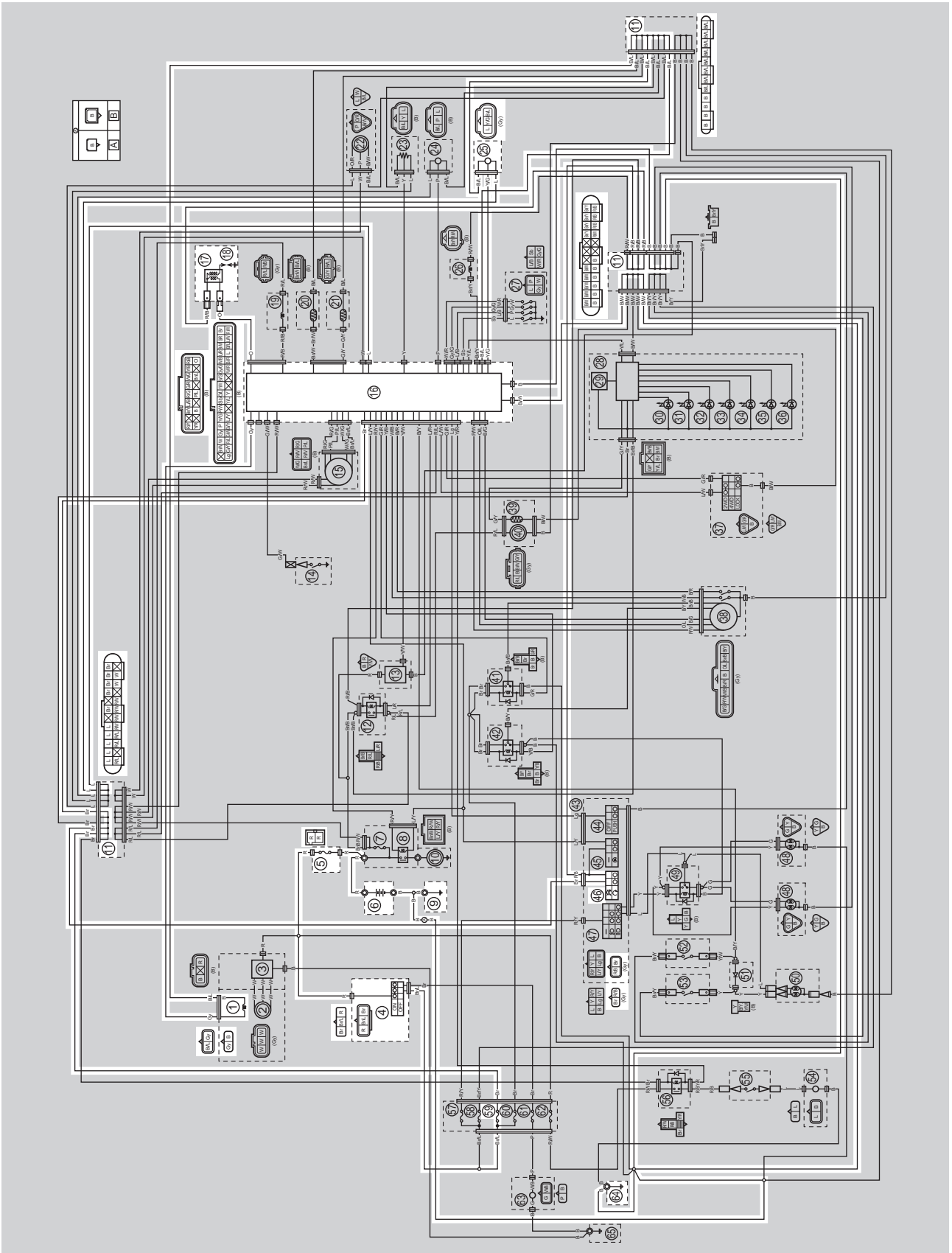

IGNITION SYSTEM

1. Crankshaft position sensor
 4. Main switch
 5. Main fuse
 6. Battery
 9. Engine ground
 11. Joint coupler
 16. ECU (engine control unit)
 17. Ignition coil
 18. Spark plug
 25. Lean angle sensor
 46. Engine stop switch
 59. Ignition fuse
 64. Frame ground 1
-
- A. Wire harness
 - B. Negative battery sub-wire harness

EAS27130

TROUBLESHOOTING

The ignition system fails to operate (no spark or intermittent spark).

TIP

• Before troubleshooting, remove the following part(s):

1. Seat
2. Battery cover
3. Right side panel
4. V-belt cooling exhaust duct

<p>1. Check the fuses. (Main and ignition) Refer to "CHECKING THE FUSES" on page 9-83.</p>	<p>NG →</p>	<p>Replace the fuse(s).</p>
<p>OK ↓</p>		
<p>2. Check the battery. Refer to "CHECKING AND CHARGING THE BATTERY" on page 9-84.</p>	<p>NG →</p>	<ul style="list-style-type: none"> • Clean the battery terminals. • Recharge or replace the battery.
<p>OK ↓</p>		
<p>3. Check the spark plug. Refer to "CHECKING THE SPARK PLUG" on page 3-7.</p>	<p>NG →</p>	<p>Re-gap, clean, or replace the spark plug.</p>
<p>OK ↓</p>		
<p>4. Check the ignition spark gap. Refer to "CHECKING THE IGNITION SPARK GAP" on page 9-91.</p>	<p>OK →</p>	<p>Ignition system is OK.</p>
<p>NG ↓</p>		
<p>5. Check the spark plug cap. Refer to "CHECKING THE SPARK PLUG CAP" on page 9-90.</p>	<p>NG →</p>	<p>Replace the spark plug cap.</p>
<p>OK ↓</p>		
<p>6. Check the ignition coil. Refer to "CHECKING THE IGNITION COIL" on page 9-90.</p>	<p>NG →</p>	<p>Replace the ignition coil.</p>
<p>OK ↓</p>		
<p>7. Check the crankshaft position sensor. Refer to "CHECKING THE CRANKSHAFT POSITION SENSOR" on page 9-91.</p>	<p>NG →</p>	<p>The crankshaft position sensor is faulty. Replace the crankshaft position sensor/stator assembly.</p>
<p>OK ↓</p>		

IGNITION SYSTEM

8. Check the main switch. Refer to "CHECKING THE SWITCHES" on page 9-79.	NG →	Replace the main switch.
OK ↓		
9. Check the engine stop switch. Refer to "CHECKING THE SWITCHES" on page 9-79.	NG →	The engine stop switch is faulty. Replace the left handlebar switch.
OK ↓		
10. Check the lean angle sensor. Refer to "CHECKING THE LEAN ANGLE SENSOR" on page 9-91.	NG →	Replace the lean angle sensor.
OK ↓		
11. Check the entire ignition system wiring. Refer to "CIRCUIT DIAGRAM" on page 9-1.	NG →	Properly connect or repair the ignition system wiring.
OK ↓		
Replace the ECU.		

ELECTRIC STARTING SYSTEM

- 4. Main switch
 - 5. Main fuse
 - 6. Battery
 - 8. Starter relay
 - 9. Engine ground
 - 10. Starter motor
 - 11. Joint coupler
 - 16. ECU (engine control unit)
 - 27. Gear position switch
 - 45. Start switch
 - 46. Engine stop switch
 - 52. Rear brake light switch
 - 58. Signaling system fuse
 - 59. Ignition fuse
 - 64. Frame ground 1
-
- A. Wire harness
 - B. Negative battery sub-wire harness

ELECTRIC STARTING SYSTEM

EAS27180

STARTING CIRCUIT CUT-OFF SYSTEM OPERATION

If the engine stop switch is set to “○” and the main switch is set to “ON” (both switch circuits are closed), the starter motor can only operate if at least one of the following conditions is met:

- The transmission is in neutral (the neutral switch circuit of the gear position switch is closed).
- The transmission is in park (the park switch circuit of the gear position switch is closed).
- The rear brake lever is pulled to the handlebar or the brake pedal is pushed down (the rear brake light switch circuit is closed).

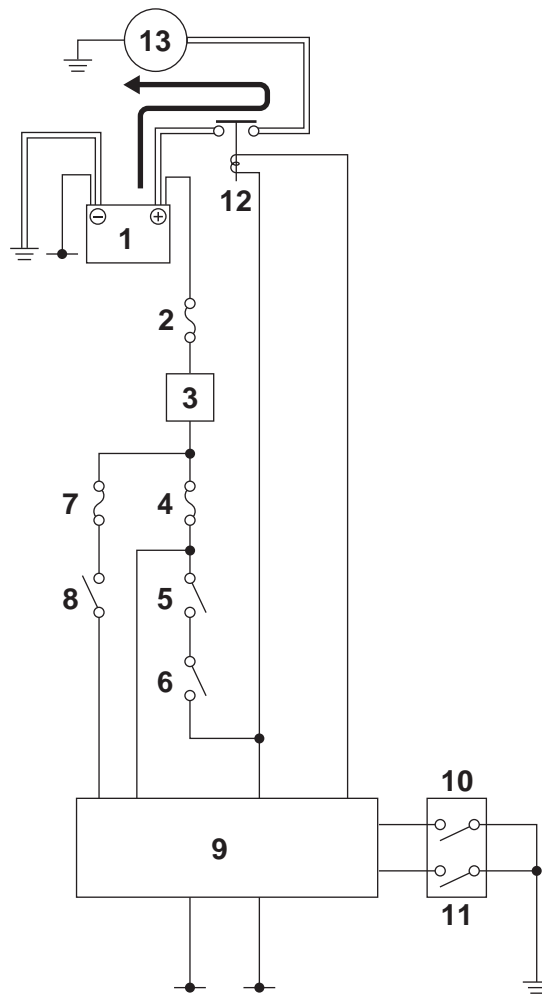

1. Battery
2. Main fuse
3. Main switch
4. Ignition fuse
5. Engine stop switch
6. Start switch
7. Signaling system fuse
8. Rear brake light switch
9. ECU (engine control unit)
10. Park switch (gear position switch)
11. Neutral switch (gear position switch)
12. Starter relay
13. Starter motor

ELECTRIC STARTING SYSTEM

EAS27190

TROUBLESHOOTING

The starter motor fails to turn.

TIP

• Before troubleshooting, remove the following part(s):

1. Seat
2. Battery cover
3. Side covers

1. Check the fuses. (Main, ignition and signaling system) Refer to "CHECKING THE FUSES" on page 9-83.	NG →	Replace the fuse(s).
OK ↓		
2. Check the battery. Refer to "CHECKING AND CHARGING THE BATTERY" on page 9-84.	NG →	<ul style="list-style-type: none">• Clean the battery terminals.• Recharge or replace the battery.
OK ↓		
3. Check the starter motor operation. Refer to "CHECKING THE STARTER MOTOR OPERATION" on page 9-92.	OK →	Starter motor is OK. Perform the electric starting system troubleshooting, starting with step 5.
NG ↓		
4. Check the starter motor. Refer to "CHECKING THE STARTER MOTOR" on page 5-41.	NG →	Repair or replace the starter motor.
OK ↓		
5. Check the starter relay. Refer to "CHECKING THE RELAYS" on page 9-87.	NG →	Replace the starter relay.
OK ↓		
6. Check the main switch. Refer to "CHECKING THE SWITCHES" on page 9-79.	NG →	Replace the main switch.
OK ↓		
7. Check the engine stop switch. Refer to "CHECKING THE SWITCHES" on page 9-79.	NG →	The engine stop switch is faulty. Replace the left handlebar switch.
OK ↓		
8. Check the start switch. Refer to "CHECKING THE SWITCHES" on page 9-79.	NG →	The start switch is faulty. Replace the left handlebar switch.
OK ↓		

ELECTRIC STARTING SYSTEM

9. Check the rear brake light switch.
Refer to "CHECKING THE SWITCHES" on page 9-79.

NG →

Replace the rear brake light switch.

OK ↓

10. Check the gear position switch.
Refer to "CHECKING THE SWITCHES" on page 9-79.

NG →

Replace the gear position switch.

OK ↓

11. Check the entire starting system wiring.
Refer to "CIRCUIT DIAGRAM" on page 9-5.

NG →

Properly connect or repair the starting system wiring.

OK ↓

Replace the ECU.

ELECTRIC STARTING SYSTEM

CHARGING SYSTEM

- 2. AC magneto
- 3. Rectifier/regulator
- 5. Main fuse
- 6. Battery
- 9. Engine ground
- 64. Frame ground 1
- 65. Frame ground 2

- A. Wire harness
- B. Negative battery sub-wire harness

CHARGING SYSTEM

EAS27230

TROUBLESHOOTING

The battery is not being charged.

TIP

• Before troubleshooting, remove the following part(s):

1. Seat
2. Battery cover
3. Right side cover
4. V-belt cooling exhaust duct

1. Check the fuse. (Main) Refer to "CHECKING THE FUSES" on page 9-83.	NG →	Replace the fuse.
OK ↓		
2. Check the battery. Refer to "CHECKING AND CHARGING THE BATTERY" on page 9-84.	NG →	<ul style="list-style-type: none">• Clean the battery terminals.• Recharge or replace the battery.
OK ↓		
3. Check the stator coil. Refer to "CHECKING THE STATOR COIL" on page 9-92.	NG →	The stator coil is faulty. Replace the crankshaft position sensor/stator assembly.
OK ↓		
4. Check the rectifier/regulator. Refer to "CHECKING THE RECTIFIER/REGULATOR" on page 9-93.	NG →	Replace the rectifier/regulator.
OK ↓		
5. Check the entire charging system wiring. Refer to "CIRCUIT DIAGRAM" on page 9-11.	NG →	Properly connect or repair the charging system wiring.
OK ↓		
The charging system circuit is OK.		

EAS27240

LIGHTING SYSTEM

EAS27250

CIRCUIT DIAGRAM

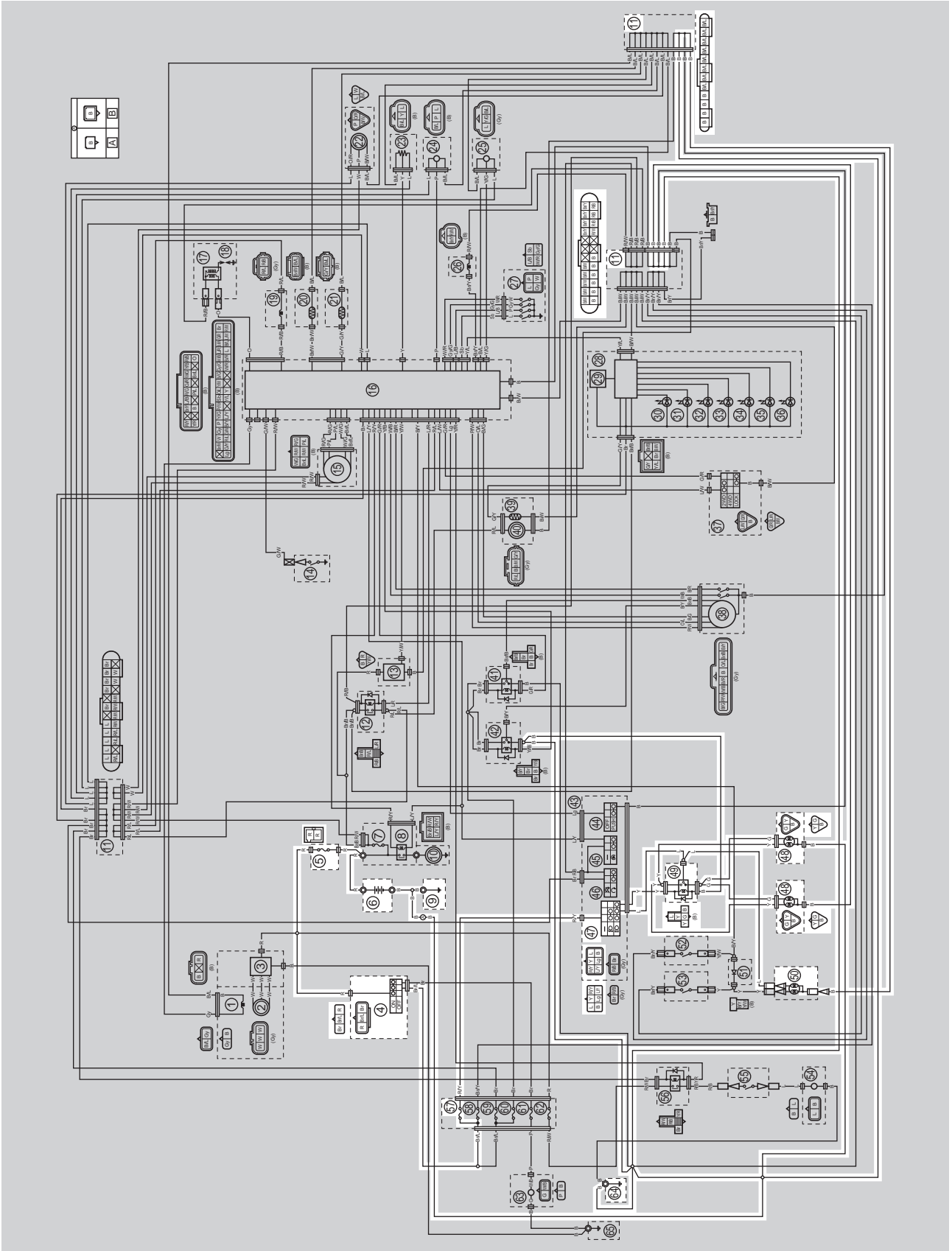

LIGHTING SYSTEM

- 4. Main switch
 - 5. Main fuse
 - 6. Battery
 - 9. Engine ground
 - 11. Joint coupler
 - 47. Light switch
 - 48. Headlight
 - 49. Headlight relay
 - 50. Tail/brake light
 - 57. Headlight fuse
 - 64. Frame ground 1
-
- A. Wire harness
 - B. Negative battery sub-wire harness

EAS27260

TROUBLESHOOTING

Any of the following fail to light: headlight or taillight.

TIP

• Before troubleshooting, remove the following part(s):

1. Seat
2. Battery cover
3. Tail/brake light cover

<p>1. Check the condition of each bulb and bulb socket. Refer to "CHECKING THE BULBS AND BULB SOCKETS" on page 9-82.</p>	<p>NG →</p>	<p>Replace the bulb(s) and bulb socket(s).</p>
<p>OK ↓</p>		
<p>2. Check the fuses. (Main and headlight) Refer to "CHECKING THE FUSES" on page 9-83.</p>	<p>NG →</p>	<p>Replace the fuse(s).</p>
<p>OK ↓</p>		
<p>3. Check the battery. Refer to "CHECKING AND CHARGING THE BATTERY" on page 9-84.</p>	<p>NG →</p>	<ul style="list-style-type: none"> • Clean the battery terminals. • Recharge or replace the battery.
<p>OK ↓</p>		
<p>4. Check the main switch. Refer to "CHECKING THE SWITCHES" on page 9-79.</p>	<p>NG →</p>	<p>Replace the main switch.</p>
<p>OK ↓</p>		
<p>5. Check the light switch. Refer to "CHECKING THE SWITCHES" on page 9-79.</p>	<p>NG →</p>	<p>The light switch is faulty. Replace the left handlebar switch.</p>
<p>OK ↓</p>		
<p>6. Check the headlight relay. Refer to "CHECKING THE RELAYS" on page 9-87.</p>	<p>NG →</p>	<p>Replace the headlight relay.</p>
<p>OK ↓</p>		
<p>7. Check the entire lighting system wiring. Refer to "CIRCUIT DIAGRAM" on page 9-15.</p>	<p>NG →</p>	<p>Properly connect or repair the lighting system wiring.</p>
<p>OK ↓</p>		
<p>The lighting system circuit is OK.</p>		

EAS27270

SIGNALING SYSTEM

EAS27280

CIRCUIT DIAGRAM (for CDN)

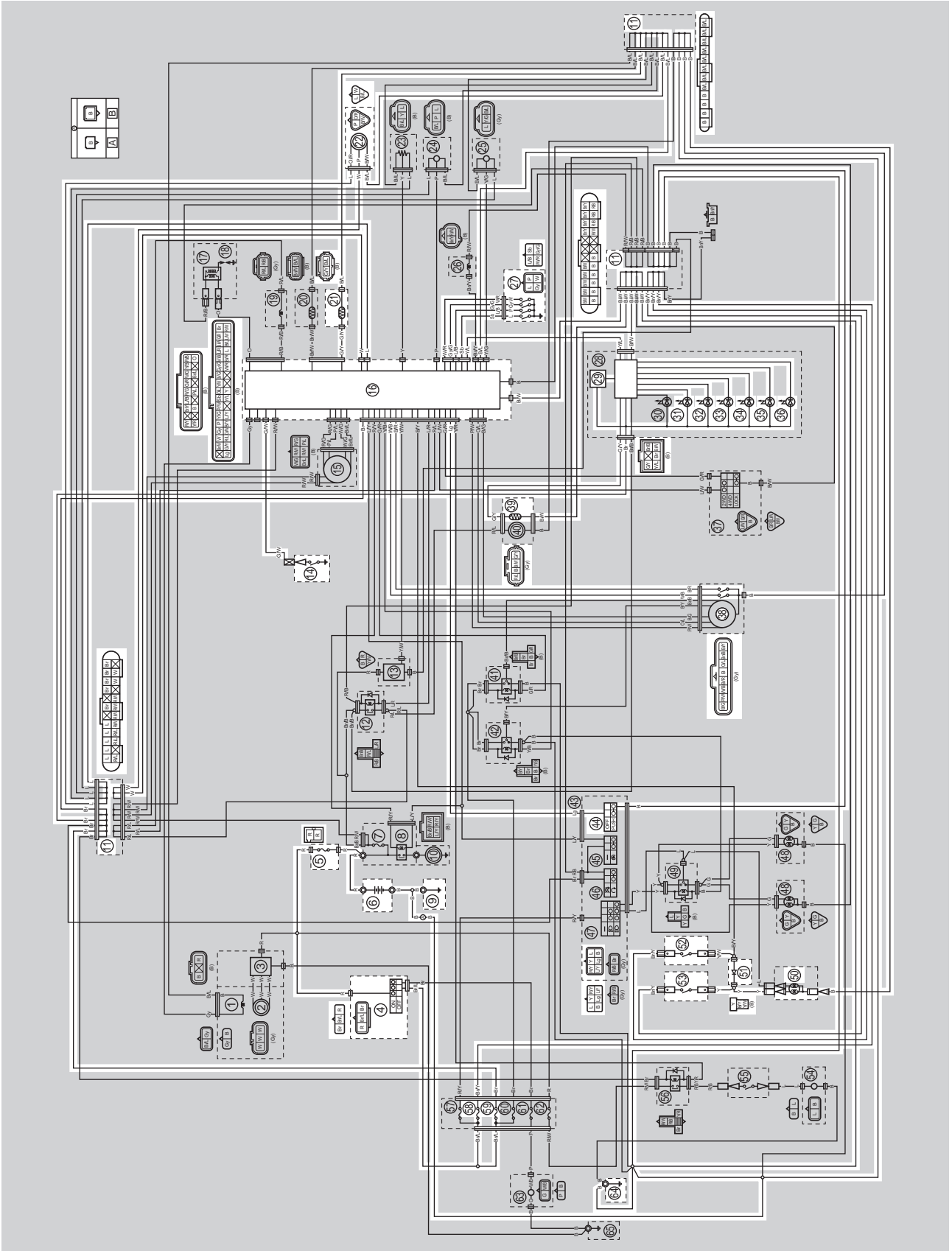

- 4. Main switch
 - 5. Main fuse
 - 6. Battery
 - 9. Engine ground
 - 11. Joint coupler
 - 14. Reverse switch
 - 16. ECU (engine control unit)
 - 21. Coolant temperature sensor
 - 22. Speed sensor
 - 27. Gear position switch
 - 29. Multifunction meter
 - 31. Coolant temperature warning light
 - 32. Park indicator light
 - 33. Reverse indicator light
 - 34. Neutral indicator light
 - 35. High-range indicator light
 - 36. Low-range indicator light
 - 38. Differential motor
 - 39. Fuel sender
 - 44. Override switch
 - 50. Tail/brake light
 - 51. Diode
 - 52. Rear brake light switch
 - 53. Front brake light switch
 - 58. Signaling system fuse
 - 59. Ignition fuse
 - 64. Frame ground 1
-
- A. Wire harness
 - B. Negative battery sub-wire harness

EAS1HP1002

CIRCUIT DIAGRAM (for Europe and Oceania)

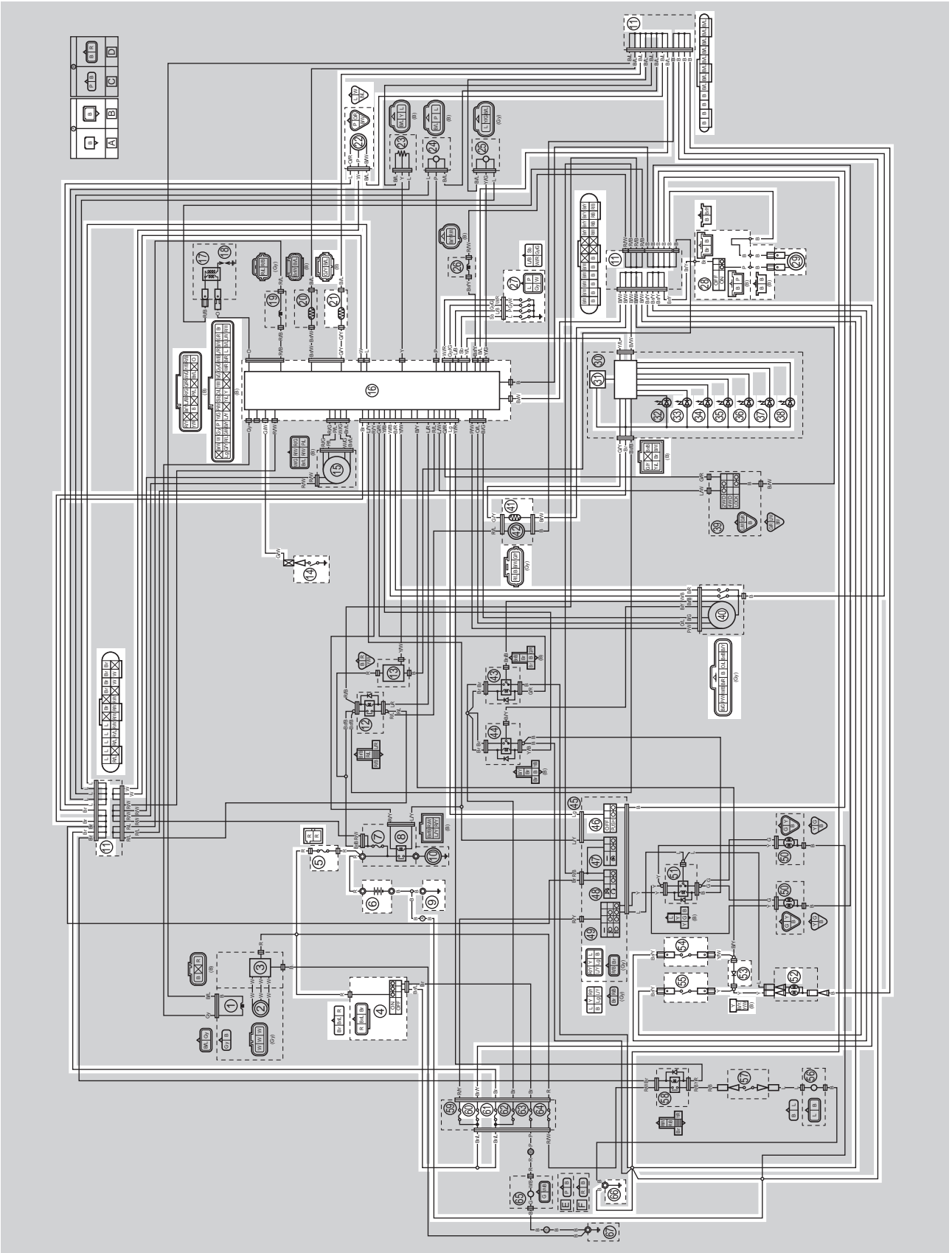

- 4. Main switch
- 5. Main fuse
- 6. Battery
- 9. Engine ground
- 11. Joint coupler
- 14. Reverse switch
- 16. ECU (engine control unit)
- 21. Coolant temperature sensor
- 22. Speed sensor
- 27. Gear position switch
- 28. Horn switch
- 29. Horn
- 31. Multifunction meter
- 33. Coolant temperature warning light
- 34. Park indicator light
- 35. Reverse indicator light
- 36. Neutral indicator light
- 37. High-range indicator light
- 38. Low-range indicator light
- 40. Differential motor
- 41. Fuel sender
- 46. Override switch
- 52. Tail/brake light
- 53. Diode
- 54. Rear brake light switch
- 55. Front brake light switch
- 60. Signaling system fuse
- 66. Frame ground 1

EAS27290

TROUBLESHOOTING

- Any of the following fail to light: warning light, brake light or an indicator light.

TIP

- Before troubleshooting, remove the following part(s):

1. Seat
2. Battery cover
3. Side panels
4. V-belt cooling exhaust duct
5. Rear fender

<p>1. Check the fuses. (Main, ignition and signaling system) Refer to "CHECKING THE FUSES" on page 9-83.</p>	NG →	<p>Replace the fuse(s).</p>
OK ↓		
<p>2. Check the battery. Refer to "CHECKING AND CHARGING THE BATTERY" on page 9-84.</p>	NG →	<ul style="list-style-type: none"> • Clean the battery terminals. • Recharge or replace the battery.
OK ↓		
<p>3. Check the main switch. Refer to "CHECKING THE SWITCHES" on page 9-79.</p>	NG →	<p>Replace the main switch.</p>
OK ↓		
<p>4. Check the entire signaling system wiring. Refer to "CIRCUIT DIAGRAM (for CDN)" on page 9-19 and "CIRCUIT DIAGRAM (for Europe and Oceania)" on page 9-21.</p>	NG →	<p>Properly connect or repair the signaling system wiring.</p>
OK ↓		
<p>Check the condition of each of the signaling system circuits. Refer to "Checking the signaling system".</p>		

Checking the signaling system

The tail/brake light fails to come on.

<p>1. Check the tail/brake light bulb and socket. Refer to "CHECKING THE BULBS AND BULB SOCKETS" on page 9-82.</p>	NG →	<p>Replace the tail/brake light bulb, socket or both.</p>
OK ↓		

SIGNALING SYSTEM

2. Check the front brake light switch. Refer to "CHECKING THE SWITCHES" on page 9-79.	NG →	Replace the front brake light switch.
OK ↓		
3. Check the rear brake light switch. Refer to "CHECKING THE SWITCHES" on page 9-79.	NG →	Replace the rear brake light switch.
OK ↓		
4. Check the diode. Refer to "CHECKING THE DIODE" on page 9-89.	NG →	Replace the diode.
OK ↓		
5. Check the entire signaling system wiring. Refer to "CIRCUIT DIAGRAM (for CDN)" on page 9-19 and "CIRCUIT DIAGRAM (for Europe and Oceania)" on page 9-21.	NG →	Properly connect or repair the signaling system wiring.
OK ↓		
This circuit is OK.		

The neutral, park, high-range, and/or low-range indicator light fails to come on.

1. Check the gear position switch. Refer to "CHECKING THE SWITCHES" on page 9-79.	NG →	Replace the gear position switch.
OK ↓		
2. Check the entire signaling system wiring. Refer to "CIRCUIT DIAGRAM (for CDN)" on page 9-19 and "CIRCUIT DIAGRAM (for Europe and Oceania)" on page 9-21.	NG →	Properly connect or repair the signaling system wiring.
OK ↓		
Replace the meter assembly or ECU.		

The reverse indicator light fails to come on.

1. Check the reverse switch. Refer to "CHECKING THE SWITCHES" on page 9-79.	NG →	Replace the reverse switch.
OK ↓		

SIGNALING SYSTEM

2. Check the entire signaling system wiring.
Refer to "CIRCUIT DIAGRAM (for CDN)" on page 9-19 and "CIRCUIT DIAGRAM (for Europe and Oceania)" on page 9-21.

NG →

Properly connect or repair the signaling system wiring.

OK ↓

Replace the meter assembly or ECU.

The differential gear lock indicator light and /or four-wheel-drive motor indicator light fails to come on.

1. Check the four-wheel-drive motor switch (differential motor).
Refer to "CHECKING THE SWITCHES" on page 9-79.

NG →

Replace the differential motor.

OK ↓

2. Check the entire signaling system wiring.
Refer to "CIRCUIT DIAGRAM (for CDN)" on page 9-19 and "CIRCUIT DIAGRAM (for Europe and Oceania)" on page 9-21.

NG →

Properly connect or repair the signaling system wiring.

OK ↓

Replace the meter assembly or ECU.

While the override switch is pushed, the segments of the speedometer digits will not appear as shown in the illustration.

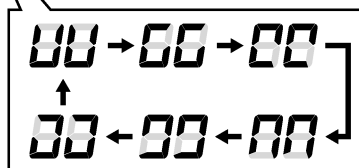
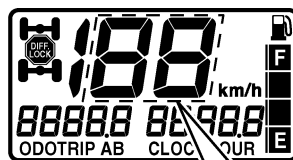

1. Check the override switch.
Refer to "CHECKING THE SWITCHES" on page 9-79.

NG →

The override switch is faulty. Replace the left handlebar switch.

OK ↓

SIGNALING SYSTEM

2. Check the entire signaling system wiring.
Refer to "CIRCUIT DIAGRAM (for CDN)" on page 9-19 and "CIRCUIT DIAGRAM (for Europe and Oceania)" on page 9-21.

NG →

Properly connect or repair the signaling system wiring.

OK ↓

Replace the meter assembly or ECU.

The coolant temperature warning light fails to come on.

1. Check the coolant temperature sensor.
Refer to "CHECKING THE COOLANT TEMPERATURE SENSOR" on page 9-95.

NG →

Replace the coolant temperature sensor.

OK ↓

2. Check the entire signaling system wiring.
Refer to "CIRCUIT DIAGRAM (for CDN)" on page 9-19 and "CIRCUIT DIAGRAM (for Europe and Oceania)" on page 9-21.

NG →

Properly connect or repair the signaling system wiring.

OK ↓

Replace the meter assembly or ECU.

The fuel level indicator fails to come on.

1. Check the fuel sender.
Refer to "CHECKING THE FUEL SENDER" on page 9-93.

NG →

Replace the fuel pump assembly.

OK ↓

2. Check the entire signaling system wiring.
Refer to "CIRCUIT DIAGRAM (for CDN)" on page 9-19 and "CIRCUIT DIAGRAM (for Europe and Oceania)" on page 9-21.

NG →

Properly connect or repair the signaling system wiring.

OK ↓

Replace the meter assembly.

The speedometer fails to operate.

1. Check the speed sensor.
Refer to "CHECKING THE SPEED SENSOR" on page 9-94.

NG →

Replace the speed sensor.

OK ↓

SIGNALING SYSTEM

2. Check the entire signaling system wiring.
Refer to "CIRCUIT DIAGRAM (for CDN)" on page 9-19 and "CIRCUIT DIAGRAM (for Europe and Oceania)" on page 9-21.

NG →

Properly connect or repair the signaling system wiring.

OK ↓

Replace the meter assembly or ECU.

The horn fails to sound (for Europe and Oceania).

1. Check the horn switch.
Refer to "CHECKING THE SWITCHES" on page 9-79.

NG →

Replace the horn switch.

OK ↓

2. Check the entire signaling system wiring.
Refer to "CIRCUIT DIAGRAM (for Europe and Oceania)" on page 9-21.

NG →

Properly connect or repair the signaling system wiring.

OK ↓

Replace the horn.

EAS27300

COOLING SYSTEM

EAS27310

CIRCUIT DIAGRAM

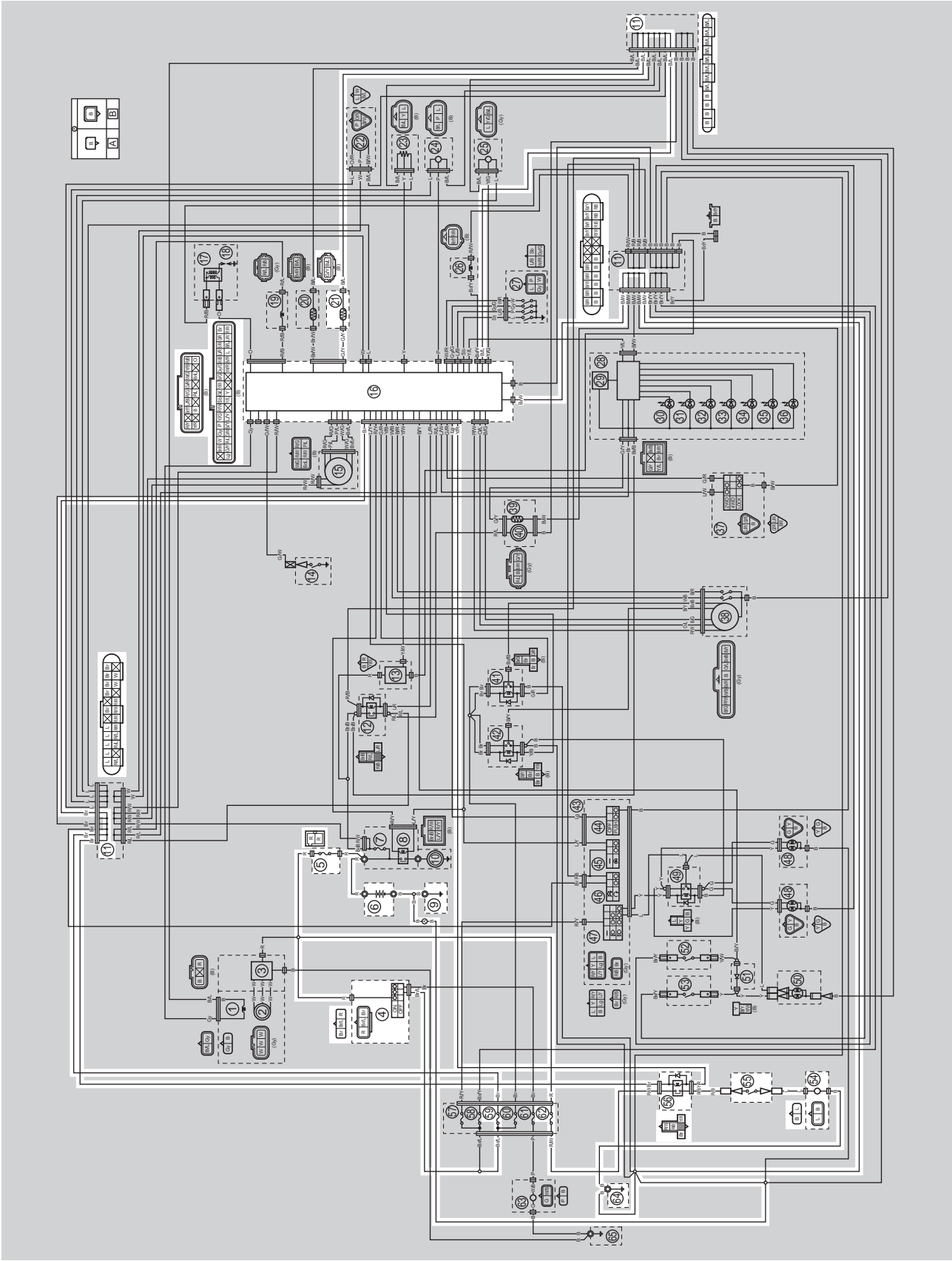

COOLING SYSTEM

- 4. Main switch
 - 5. Main fuse
 - 6. Battery
 - 9. Engine ground
 - 11. Joint coupler
 - 16. ECU (engine control unit)
 - 21. Coolant temperature sensor
 - 54. Radiator fan motor
 - 55. Radiator fan motor circuit breaker
 - 56. Radiator fan motor relay
 - 59. Ignition fuse
 - 62. Radiator fan motor fuse
 - 64. Frame ground 1
-
- A. Wire harness
 - B. Negative battery sub-wire harness

EAS27320

TROUBLESHOOTING

The radiator fan motor fails to turn.

TIP

• Before troubleshooting, remove the following part(s):

1. Seat
2. Battery cover
3. Side panels
4. Front fenders

<p>1. Check the fuses. (Main, ignition and radiator fan motor) Refer to "CHECKING THE FUSES" on page 9-83.</p>	<p>NG →</p>	<p>Replace the fuse(s).</p>
OK ↓		
<p>2. Check the battery. Refer to "CHECKING AND CHARGING THE BATTERY" on page 9-84.</p>	<p>NG →</p>	<ul style="list-style-type: none"> • Clean the battery terminals. • Recharge or replace the battery.
OK ↓		
<p>3. Check the main switch. Refer to "CHECKING THE SWITCHES" on page 9-79.</p>	<p>NG →</p>	<p>Replace the main switch.</p>
OK ↓		
<p>4. Check the radiator fan motor. Refer to "CHECKING THE RADIATOR FAN MOTOR" on page 9-94.</p>	<p>NG →</p>	<p>The radiator fan motor is faulty and must be replaced.</p>
OK ↓		
<p>5. Check the radiator fan motor relay. Refer to "CHECKING THE RELAYS" on page 9-87.</p>	<p>NG →</p>	<p>Replace the radiator fan motor relay.</p>
OK ↓		
<p>6. Check the radiator fan motor circuit breaker. Refer to "CHECKING THE RADIATOR FAN MOTOR CIRCUIT BREAKER" on page 9-94.</p>	<p>NG →</p>	<p>Replace the radiator fan motor circuit breaker.</p>
OK ↓		
<p>7. Check the coolant temperature sensor. Refer to "CHECKING THE COOLANT TEMPERATURE SENSOR" on page 9-95.</p>	<p>NG →</p>	<p>Replace the coolant temperature sensor.</p>
OK ↓		

COOLING SYSTEM

8. Check the entire cooling system wiring.
Refer to "CIRCUIT DIAGRAM" on page 9-29.

NG →

Properly connect or repair the cooling system wiring.

OK ↓

Replace the ECU.

EAS27330

FUEL INJECTION SYSTEM

EAS27340

CIRCUIT DIAGRAM

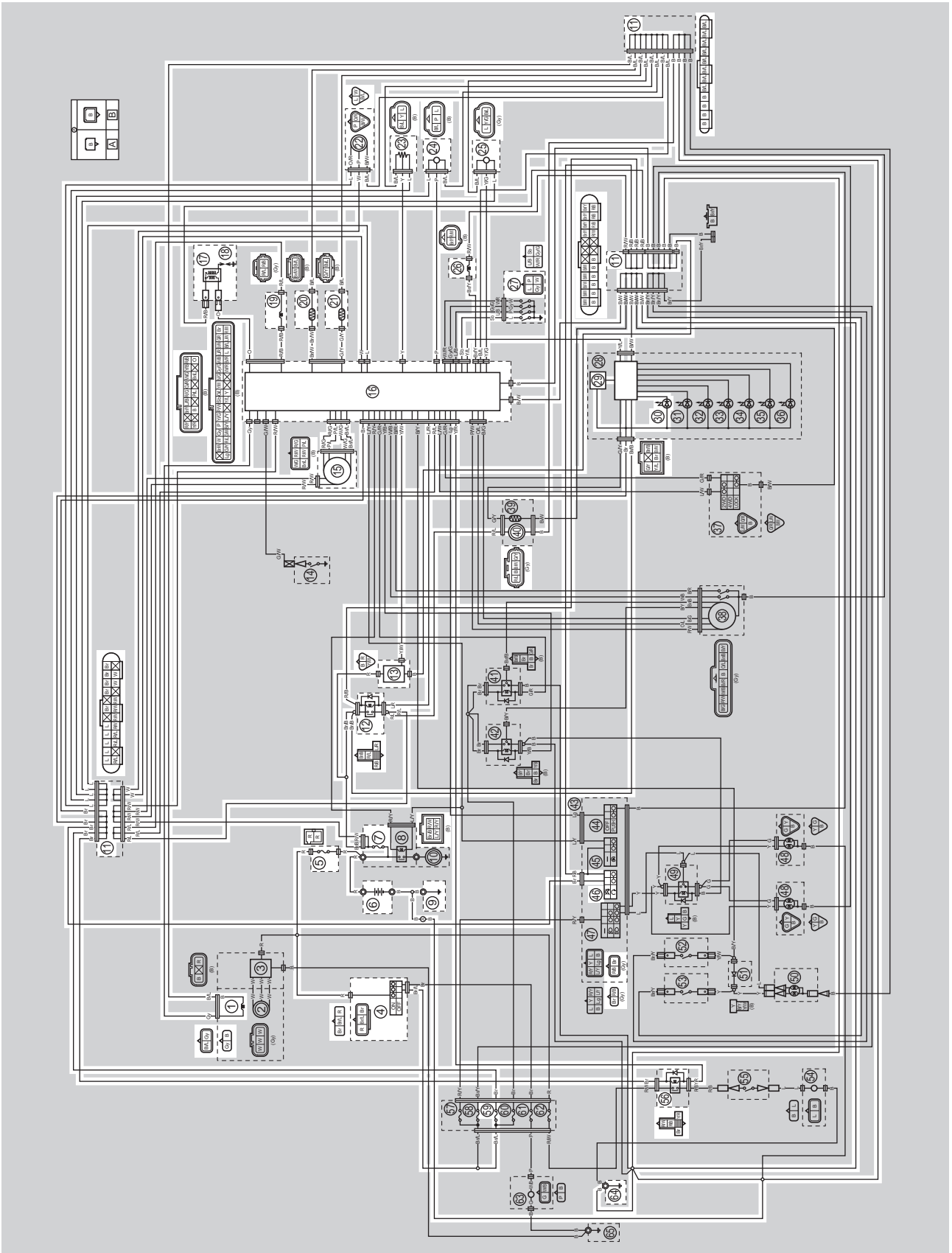

FUEL INJECTION SYSTEM

1. Crankshaft position sensor
 4. Main switch
 5. Main fuse
 6. Battery
 7. Fuel injection system fuse
 9. Engine ground
 11. Joint coupler
 12. Fuel injection system relay
 13. Yamaha diagnostic tool coupler
 15. ISC (idle speed control) unit
 16. ECU (engine control unit)
 17. Ignition coil
 18. Spark plug
 19. Fuel injector
 20. Intake air temperature sensor
 21. Coolant temperature sensor
 22. Speed sensor
 23. TPS (throttle position sensor)
 24. Intake air pressure sensor
 25. Lean angle sensor
 26. Air induction system solenoid
 27. Gear position switch
 28. Multifunction meter
 29. Engine trouble warning light
 40. Fuel pump
 46. Engine stop switch
 56. Radiator fan motor relay
 59. Ignition fuse
 64. Frame ground 1
- A. Wire harness
B. Negative battery sub-wire harness

EAS27350

ECU SELF-DIAGNOSTIC FUNCTION

The ECU is equipped with a self-diagnostic function in order to ensure that the fuel injection system is operating normally. If this function detects a malfunction in the system, it immediately operates the engine under substitute characteristics and illuminates the engine trouble warning light to alert the rider that a malfunction has occurred in the system. Once a malfunction has been detected, a fault code is stored in the memory of the ECU.

- To inform the rider that the fuel injection system is not functioning, the engine trouble warning light flashes when the start switch is being pushed to start the engine.
- If a malfunction is detected in the system by the self-diagnostic function, the ECU provides an appropriate substitute characteristic operation, and alerts the rider of the detected malfunction by illuminating the engine trouble warning light.
- After the engine has been stopped, the lowest fault code number appears on the clock LCD. Once a fault code has been displayed, it remains stored in the memory of the ECU until it is deleted.



1. Engine trouble warning light

Engine trouble warning light indication and FI system operation

Warning light indication	ECU operation	FI operation	Vehicle operation
Flashing*	Warning provided when unable to start engine	Operation stopped	Cannot be operated
Remains on	Malfunction detected	Operated with substitute characteristics in accordance with the description of the malfunction	Can or cannot be operated depending on the fault code

* The warning light flashes when any one of the conditions listed below is present and the start switch is pushed:

12: Crankshaft position sensor

41: Lean angle sensor (open or short-circuit)

30: Lean angle sensor (latch up detected)

50: ECU internal malfunction (faulty ECU memory)

EAS27380

SELF-DIAGNOSTIC FUNCTION TABLE

If the ECU detects an abnormal signal from a sensor while the vehicle is being driven, the ECU illuminates the engine trouble warning light and provides the engine with alternate operating instructions that are appropriate for the type of malfunction.

When an abnormal signal is received from a sensor, the ECU processes the specified values that are programmed for each sensor in order to provide the engine with alternate operating instructions that enable the engine to continue to operate or stop operating, depending on the conditions.

FUEL INJECTION SYSTEM

Self-diagnostic function table

Fault code No.	Item	Symptom	Able / unable to start	Able / unable to drive
12	Crankshaft position sensor	No normal signals are received from the crankshaft position sensor.	Unable	Unable
13	Intake air pressure sensor (open or short circuit)	Intake air pressure sensor—open or short circuit detected.	Able	Able
14	Intake air pressure sensor (hose line)	Intake air pressure sensor: hose line malfunction (clogged or detached hose).	Able	Able
15	Throttle position sensor (open or short circuit)	Throttle position sensor: open or short circuit detected.	Able	Able
16	Throttle position sensor (stuck)	Stuck throttle position sensor detected.	Able	Able
21	Coolant temperature sensor (open or short circuit)	Coolant temperature sensor: open or short circuit detected.	Able	Able
22	Intake air temperature sensor (open or short circuit)	Intake air temperature sensor: open or short circuit detected.	Able	Able
30	Lean angle sensor (latch up detected)	The vehicle has overturned.	Unable	Unable
33	Ignition coil (faulty ignition)	Malfunction detected in the primary wire of the ignition coil.	Unable	Unable
37	ISC valve (stuck fully open)	Engine speed is high when the engine is idling.	Able	Able
39	Fuel injector (open circuit)	Fuel injector: open circuit detected.	Unable	Unable
41	Lean angle sensor (open or short circuit)	Lean angle sensor: open or short circuit detected.	Unable	Unable
42	Speed sensor	No normal signals are received from the speed sensor.	Able	Able
43	Fuel system voltage (monitoring voltage)	The ECU is unable to monitor the battery voltage (an open or short circuit in the line to the ECU).	Able	Able
44	Error in writing the amount of CO adjustment on EEPROM	Error is detected while reading or writing on EEPROM (CO adjustment value).	Able	Able
46	Vehicle system power supply (Monitoring voltage)	Power supply to the fuel injection system is not normal.	Able	Able

FUEL INJECTION SYSTEM

4. Turn the main switch to "OFF" and back to "ON", then check the fault code number is not displayed.

TIP

If fault codes are displayed, repeat steps (1) to (4) until no fault code number is displayed.

5. Erase the malfunction history in the diagnostic mode. Refer to "Sensor operation table (diagnostic code No.d62)".

The engine operation is not normal but the engine trouble warning light does not come on.

1. Check the operation of following sensors and actuators in the diagnostic mode. Refer to "Sensor operation table" and "Actuator operation table".

d01: Throttle position sensor (throttle angle) d30: Ignition coil d36: Injector

If a malfunction is detected in the sensors or actuators, repair or replace all faulty parts. If no malfunction is detected in the sensors and actuators, check and repair inner parts of the engine.

EAS2BG1002

YAMAHA DIAGNOSTIC TOOL

This model uses the Yamaha diagnostic tool to identify malfunctions.

For information about using the Yamaha diagnostic tool, refer to the operation manual that is included with the tool.

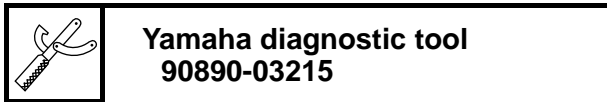

Features of the Yamaha diagnostic tool

You can use the Yamaha diagnostic tool to identify malfunctions quicker than with conventional methods.

By connecting the adapter interface, which is connected to the USB port of a computer, to a vehicle's ECU using the communication cable, you can display information that is necessary for identifying malfunctions and for maintenance to display on the computer. The displayed information includes the sensor output data and information recorded in the ECU.

Functions of the Yamaha diagnostic tool

Fault diagnosis mode:	Fault codes recorded on the ECU are read, and the contents are displayed.
Function diagnostic mode:	Check the operation of the output value of each sensor and actuator.
Inspection mode:	Determine whether each sensor or actuator is functioning properly.
CO adjustment mode:	Adjust the concentration of CO admissions during idling.
Monitoring mode:	Displays a graph of sensor output values for actual operating conditions.
Logging mode:	Records and saves the sensor output value in actual driving conditions.
View log:	Displays the logging data.
ECU rewrite:	If necessary, the ECU is rewritten using ECU rewrite data provided by Yamaha. Ignition timing adjustment, etc. cannot be changed from the vehicle's original state.

However, the diagnostic tool cannot be used to freely change the basic vehicle functions, such as adjusting the ignition timing.

FUEL INJECTION SYSTEM

Connecting the Yamaha diagnostic tool

Remove the protective cap, and then connect the Yamaha diagnostic tool to the coupler "1".

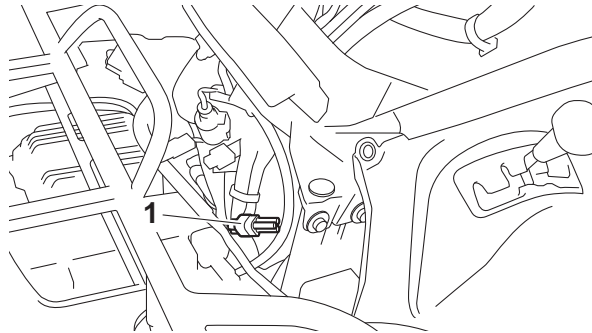

TIP

When the Yamaha diagnostic tool is connected to the vehicle, the operation of the multi-function meter and indicators will be different from the normal operation.

Diagnostic code table

Fault code No.	Symptom	Probable cause of malfunction	Diagnostic code No.
12	No normal signals are received from the crankshaft position sensor.	<ul style="list-style-type: none"> • Open or short circuit in wire harness. • Defective crankshaft position sensor. • Malfunction in crankshaft position sensor rotor. • Malfunction in ECU. • Improperly installed sensor. 	—
13	Intake air pressure sensor: open or short circuit detected.	<ul style="list-style-type: none"> • Open or short circuit in wire harness. • Defective intake air pressure sensor. • Malfunction in ECU. 	d03
14	Intake air pressure sensor: hose line malfunction (clogged or detached hose).	<ul style="list-style-type: none"> • Intake air pressure sensor hose is detached, clogged, kinked, or pinched. • Malfunction in ECU. 	d03
15	Throttle position sensor: open or short circuit detected.	<ul style="list-style-type: none"> • Open or short circuit in wire harness. • Defective throttle position sensor. • Malfunction in ECU. • Improperly installed throttle position sensor. 	d01
16	Stuck throttle position sensor detected.	<ul style="list-style-type: none"> • Stuck throttle position sensor. • Malfunction in ECU. 	d01
21	Coolant temperature sensor: open or short circuit detected.	<ul style="list-style-type: none"> • Open or short circuit in wire harness. • Defective coolant temperature sensor. • Malfunction in ECU. • Improperly installed coolant temperature sensor. 	d06
22	Intake air temperature sensor: open or short circuit detected.	<ul style="list-style-type: none"> • Open or short circuit in wire harness. • Defective intake temperature sensor. • Malfunction in ECU. • Improperly installed intake air temperature sensor. 	d05
30	The vehicle has overturned.	<ul style="list-style-type: none"> • The vehicle has overturned. • Malfunction in ECU. 	d08

FUEL INJECTION SYSTEM

Fault code No.	Symptom	Probable cause of malfunction	Diagnostic code No.
33	Malfunction detected in the primary lead of the ignition coil.	<ul style="list-style-type: none"> • Open or short circuit in wire harness. • Malfunction in ignition coil. • Malfunction in ECU. • Malfunction in a component of ignition cut-off circuit system. 	d30
37	Engine speed is high when the engine is idling.	<ul style="list-style-type: none"> • Open circuit in wire harness. • Malfunction in throttle body. • Malfunction in throttle cables. • ISC valve is stuck fully open due to disconnected ISC unit hose or coupler. (High engine idle speed is detected with the ISC valve stuck fully open even though signals for the valve to close are continuously being transmitted by the ECU.) • Malfunction in ECU. • Fuel injection system fuse is blown. 	d54
39	Fuel injector: open or short circuit detected.	<ul style="list-style-type: none"> • Open or short circuit in wire harness. • Defective fuel injector. • Improperly installed fuel injector. 	d36
41	Lean angle sensor: open or short circuit detected.	<ul style="list-style-type: none"> • Open or short circuit in wire harness. • Defective lean angle sensor. • Malfunction in ECU. 	d08
42	No normal signals are received from the speed sensor.	<ul style="list-style-type: none"> • Open circuit in wiring harness. • Defective speed sensor. • Malfunction in vehicle speed sensor detected. • Malfunction in the engine side of the neutral switch. • Malfunction in ECU. 	d07
43	Power supply to the fuel injector and fuel pump is not normal.	<ul style="list-style-type: none"> • Open or short circuit in wire harness. • Malfunction in ECU. 	d09
44	Error is detected while reading or writing on EEPROM (CO adjustment value).	<ul style="list-style-type: none"> • Malfunction in ECU. (The CO adjustment value is not properly written on or read from the internal memory.) 	d60
46	Power supply to the fuel injection system is not normal.	<ul style="list-style-type: none"> • Malfunction in charging system. Refer to "CHARGING SYSTEM" on page 9-11. 	—
50	Faulty ECU memory. (When this malfunction is detected in the ECU, the fault code number might not appear on the multi-function meter.)	<ul style="list-style-type: none"> • Malfunction in ECU. (The program and data are not properly written on or read from the internal memory.) 	—

FUEL INJECTION SYSTEM

Sensor operation table

Diagnostic code No.	Item	Meter display	Checking method
d01	Throttle angle <ul style="list-style-type: none"> • Fully closed position • Fully opened position 	12–22 91–111	Check with throttle fully closed. Check with throttle fully open.
d03	Pressure difference (atmospheric pressure and intake air pressure)	Displays the intake air pressure.	Set the engine stop switch to “○”, then operate the throttle while pushing the start switch. (If the display value changes, the performance is OK.)
d05	Intake air temperature	Displays the intake air temperature.	Compare the actually measured intake air temperature with the meter display value.
d06	Coolant temperature	Displays the coolant temperature.	Compare the actually measured coolant temperature with the meter display value.
d07	Vehicle speed pulse	0–999	Check that the number increases when the rear wheels are rotated. The number is cumulative and does not reset each time the wheel is stopped.
d08	Lean angle sensor <ul style="list-style-type: none"> • Upright • Overturned 	3.7–4.4 0.4–1.4	Remove the lean angle sensor and incline it more than 65 degrees.
d09	Fuel system voltage (battery voltage)	Approximately 12.0	Set the engine stop switch to “○”, and then compare with the actually measured battery voltage. (If the battery voltage is lower, perform recharging.)
d21	Neutral switch <ul style="list-style-type: none"> • Neutral • In gear 	ON OFF	Shift the transmission.
d60	EEPROM fault code display <ul style="list-style-type: none"> • No history • History exists 	00 01	—

FUEL INJECTION SYSTEM

Diagnostic code No.	Item	Meter display	Checking method
d61	Malfunction history code display <ul style="list-style-type: none"> • No history • History exists 	00 Fault codes 12–50 <ul style="list-style-type: none"> • (If more than one code number is detected, the display alternates every two seconds to show all the detected code numbers. When all code numbers are shown, the display repeats the same process.) 	—
d62	Malfunction history code erasure <ul style="list-style-type: none"> • No history • History exists 	0 Up to 16 fault codes	— To erase the history, set the engine stop switch to “⊗” and then to “○”.
d70	Control number	00–255	—

Actuator operation table

- Actuator operation

Set the engine stop switch to “⊗” and then to “○”.

Diagnostic code No.	Item	Actuation	Checking method
d30	Ignition coil	Actuates the ignition coil five times in one-second intervals. The engine trouble warning light also flashes five times.	Check the spark five times. <ul style="list-style-type: none"> • Connect an ignition checker.
d36	Injector	Actuates the injector five times in one-second intervals. The engine trouble warning light also flashes five times.	Check the operating sound of the injector five times.
d48	Air induction system solenoid	Actuates the air induction system solenoid five times at one-second intervals. Illuminates the engine trouble warning light.	Check that the air induction system solenoid is actuated five times by listening for the operating sound.

FUEL INJECTION SYSTEM

Diagnostic code No.	Item	Actuation	Checking method
d50	Fuel injection system	Actuates the fuel injection system relay five times in one-second intervals. The engine trouble warning light also flashes five times. (The engine trouble warning light is OFF when the relay is ON, and the engine trouble warning light is ON when the relay is OFF).	Check the operating sound of the fuel injection system relay five times.
d51	Radiator fan motor relay	Actuates the radiator fan motor relay and illuminates the engine trouble warning light five cycles (5 seconds per cycle—2 seconds ON, 3 seconds OFF).	Check the operating sound of the radiator fan motor relay five times.
d54	ISC valve	Actuates and fully closes the ISC valve, then opens it to the standby opening position when the engine is started. This operation takes approximately 12 seconds until it is completed. Illuminates the engine trouble warning light.	The ISC unit vibrates when the ISC valve operates.

EAS27481

TROUBLESHOOTING DETAILS

This section describes the measures per fault code number displayed on the meter. Check and service the items or components that are the probable cause of the malfunction following the order given. After the check and service of the malfunctioning part have been completed, reset the meter display according to the reinstatement method.

Fault code No.:

Code number displayed on the meter when the engine failed to work normally. Refer to “Self-Diagnostic Function table”.

Diagnostic code No.:

Diagnostic code number to be used when the diagnostic mode is operated. Refer to “YAMAHA DIAGNOSTIC TOOL” on page 9-38.

FUEL INJECTION SYSTEM

Fault code No.	12	Symptom	No normal signals are received from the crankshaft position sensor.	
Diagnostic code No.	—	—		
Order	Item/components and probable cause		Check or maintenance job	Reinstatement method
1	Installed condition of crankshaft position sensor		Check for looseness or pinching.	Cranking the engine.
2	Connections <ul style="list-style-type: none"> • Crankshaft position sensor coupler • Main wire harness-ECU coupler 		<ul style="list-style-type: none"> • Check the coupler for any pins that may have pulled out. • Check the locking condition of the coupler. • If there is a malfunction, repair it and connect the coupler securely. 	
3	Open or short circuit in wire harness.		<ul style="list-style-type: none"> • Repair or replace if there is an open or short circuit. • Between the crankshaft position sensor coupler and ECU coupler. (gray-gray) (black/blue-black/blue) 	
4	Defective crankshaft position sensor.		<ul style="list-style-type: none"> • Replace the crankshaft position sensor/stator assembly. Refer to “CHECKING THE CRANKSHAFT POSITION SENSOR” on page 9-91. 	

FUEL INJECTION SYSTEM

Fault code No.	13	Symptom	Intake air pressure sensor: open or short circuit detected.	
Diagnostic code No.	d03	Intake air pressure sensor		
Order	Item/components and probable cause		Check or maintenance job	Reinstatement method
1	Connections <ul style="list-style-type: none"> • Intake air pressure sensor coupler • Main wire harness-ECU coupler 		<ul style="list-style-type: none"> • Check the coupler for any pins that may have pulled out. • Check the locking condition of the coupler. • If there is a malfunction, repair it and connect the coupler securely. 	Setting the main switch to "ON".
2	Open or short circuit in wire harness.		<ul style="list-style-type: none"> • Repair or replace if there is an open or short circuit. • Between intake air pressure sensor coupler and ECU coupler (black/blue–black/blue) (pink–pink) (blue–blue) 	
3	Defective intake air pressure sensor.		<ul style="list-style-type: none"> • Execute the diagnostic mode. (Code No. d03) • Replace if defective. Refer to "CHECKING THE INTAKE AIR PRESSURE SENSOR" on page 9-96. 	

FUEL INJECTION SYSTEM

Fault code No.	14	Symptom	Intake air pressure sensor: hose line malfunction (clogged or detached hose).	
Diagnostic code No.	d03	Intake air pressure sensor		
Order	Item/components and probable cause		Check or maintenance job	Reinstatement method
1	Intake air pressure sensor hose.		<ul style="list-style-type: none"> • Check the intake air pressure sensor hose condition. • Repair or replace the sensor hose. 	Starting the engine and operating it at idle.
2	Intake air pressure sensor malfunction at intermediate electrical potential.		<ul style="list-style-type: none"> • Check and repair the connection. • Replace it if there is a malfunction. 	
3	Connections <ul style="list-style-type: none"> • Intake air pressure sensor coupler • Main wire harness-ECU coupler 		<ul style="list-style-type: none"> • Check the coupler for any pins that may have pulled out. • Check the locking condition of the coupler. • If there is a malfunction, repair it and connect the coupler securely. 	
4	Defective intake air pressure sensor.		<ul style="list-style-type: none"> • Execute the diagnostic mode. (Code No. d03) • Replace if defective. Refer to "CHECKING THE INTAKE AIR PRESSURE SENSOR" on page 9-96. 	

FUEL INJECTION SYSTEM

Fault code No.	15	Symptom	Throttle position sensor: open or short circuit detected.	
Diagnostic code No.	d01	Throttle position sensor		
Order	Item/components and probable cause		Check or maintenance job	Reinstatement method
1	Installed condition of throttle position sensor.		<ul style="list-style-type: none"> • Check for looseness or pinching. • Check that the sensor is installed in the specified position. 	Setting the main switch to "ON".
2	Connections <ul style="list-style-type: none"> • Throttle position sensor coupler • Main wire harness-ECU coupler 		<ul style="list-style-type: none"> • Check the coupler for any pins that may have pulled out. • Check the locking condition of the coupler. • If there is a malfunction, repair it and connect the coupler securely. 	
3	Open or short circuit in wire harness.		<ul style="list-style-type: none"> • Repair or replace if there is an open or short circuit. • Between throttle position sensor coupler and ECU coupler (black/blue-black/blue) (yellow-yellow) (blue-blue) 	
4	Defective throttle position sensor.		<ul style="list-style-type: none"> • Execute the diagnostic mode. (Code No. d01) • Replace if defective. Refer to "CHECKING THE THROTTLE POSITION SENSOR" on page 9-95. 	

Fault code No.	16	Symptom	Stuck throttle position sensor detected.	
Diagnostic code No.	d01	Throttle position sensor		
Order	Item/components and probable cause		Check or maintenance job	Reinstatement method
1	Installed condition of throttle position sensor.		<ul style="list-style-type: none"> • Check the installed area for looseness or pinching. • Check that the throttle position sensor is installed in the specified position. Refer to "ADJUSTING THE THROTTLE POSITION SENSOR" on page 7-7. 	Reinstated by starting the engine, operating it at idle, and then racing it.
2	Defective throttle position sensor.		<ul style="list-style-type: none"> • Execute the diagnostic mode. (Code No. d01) • Replace if defective. Refer to "CHECKING THE THROTTLE POSITION SENSOR" on page 9-95. 	

FUEL INJECTION SYSTEM

Fault code No.	21	Symptom	Coolant temperature sensor: open or short circuit detected.	
Diagnostic code No.	d06	Coolant temperature sensor		
Order	Item/components and probable cause		Check or maintenance job	Reinstatement method
1	Installed condition of coolant temperature sensor.		Check the installed area for looseness or pinching.	Setting the main switch to "ON".
2	Connections <ul style="list-style-type: none"> • Coolant temperature sensor coupler • Main wire harness-ECU coupler 		<ul style="list-style-type: none"> • Check the coupler for any pins that may have pulled out. • Check the locking condition of the coupler. • If there is a malfunction, repair it and connect the coupler securely. 	
3	Open or short circuit in wire harness.		<ul style="list-style-type: none"> • Repair or replace if there is an open or short circuit. • Between coolant temperature sensor coupler and ECU coupler. (black/blue–black/blue) (green/yellow–green/yellow) 	
4	Defective coolant temperature sensor.		<ul style="list-style-type: none"> • Execute the diagnostic mode. (Code No. d06) • Replace if defective. Refer to "CHECKING THE COOLANT TEMPERATURE SENSOR" on page 9-95. 	

FUEL INJECTION SYSTEM

Fault code No.	22	Symptom	Intake air temperature sensor: open or short circuit detected.	
Diagnostic code No.	d05	Intake air temperature sensor		
Order	Item/components and probable cause		Check or maintenance job	Reinstatement method
1	Installed condition of intake air temperature sensor.		Check for looseness or pinching.	Setting the main switch to "ON".
2	Connections <ul style="list-style-type: none"> • Intake air temperature sensor coupler • Main wire harness-ECU coupler 		<ul style="list-style-type: none"> • Check the coupler for any pins that may have pulled out. • Check the locking condition of the coupler. • If there is a malfunction, repair it and connect the coupler securely. 	
3	Open or short circuit in wire harness.		<ul style="list-style-type: none"> • Repair or replace if there is an open or short circuit. • Between intake air temperature sensor coupler and ECU coupler. (black/blue–black/blue) (brown/white–brown/white) 	
4	Defective intake air temperature sensor.		<ul style="list-style-type: none"> • Execute the diagnostic mode. (Code No. d05) • Replace if defective. Refer to "CHECKING THE INTAKE AIR TEMPERATURE SENSOR" on page 9-97. 	

FUEL INJECTION SYSTEM

Fault code No.	30	Symptom	The vehicle has overturned.	
Diagnostic code No.	d08	Lean angle sensor		
Order	Item/components and probable cause		Check or maintenance job	Reinstatement method
1	The vehicle has overturned.		Raise the vehicle upright.	Setting the main switch to "ON" (however, the engine cannot be restarted unless the main switch is first set to "OFF").
2	Installed condition of the lean angle sensor.		Check for looseness or pinching.	
3	Connections <ul style="list-style-type: none"> • Lean angle sensor coupler • Main wire harness-ECU coupler 		<ul style="list-style-type: none"> • Check the coupler for any pins that may be pulled out. • Check the locking condition of the coupler. • If there is a malfunction, repair it and connect the coupler securely. 	
4	Defective lean angle sensor.		<ul style="list-style-type: none"> • Execute the diagnostic mode. (Code No. d08) • Replace if defective. Refer to "CHECKING THE LEAN ANGLE SENSOR" on page 9-91. 	

FUEL INJECTION SYSTEM

Fault code No.	33	Symptom	Malfunction detected in the primary lead of the ignition coil.	
Diagnostic code No.	d30	Ignition coil		
Order	Item/components and probable cause		Check or maintenance job	Reinstatement method
1	Connections <ul style="list-style-type: none"> • Ignition coil connector (primary coil side) • Main wire harness-ECU coupler 		<ul style="list-style-type: none"> • Check the connector and coupler for any pins that may have pulled out. • Check the locking condition of the connector and coupler. • If there is a malfunction, repair it and connect the connector or coupler securely. 	Starting the engine and operating it at idle.
2	Open or short circuit in wire harness.		<ul style="list-style-type: none"> • Repair or replace if there is an open or short circuit. • Between ignition coil connector and ECU coupler. (orange–orange) • Between ignition coil connector and left handlebar switch coupler. (red/black–red/black) 	
3	Defective ignition coil		<ul style="list-style-type: none"> • Execute the diagnostic mode. (Code No. d30) • Test the primary and secondary coils for continuity. • Replace if defective. Refer to “CHECKING THE IGNITION COIL” on page 9-90. 	

FUEL INJECTION SYSTEM

Order	Item/components and probable cause	Check or maintenance job	Reinstatement method
Fault code No. 37		Symptom Engine speed is high when the engine is idling.	
Diagnostic code No. d54		ISC valve	
1	Fuel injection system fuse is blown.	<ul style="list-style-type: none"> • Check the fuel injection system fuse. Refer to "CHECKING THE FUSES" on page 9-83. 	ISC valve returns to its original position by setting the main switch to "ON" and back to "OFF". Reinstated if the engine idle speed is within specification after starting the engine.
2	Throttle valve does not fully close.	<ul style="list-style-type: none"> • Check the throttle body. Refer to "THROTTLE BODY" on page 7-4. • Check the throttle cables. Refer to "ADJUSTING THE THROTTLE LEVER FREE PLAY" on page 3-6. 	
3	ISC valve is stuck fully open due to disconnected ISC unit coupler. (High engine idle speed is detected with the ISC valve stuck fully open even though signals for the valve to close are continuously being transmitted by the ECU.)	<ul style="list-style-type: none"> • Check that the ISC unit coupler is not disconnected. • The ISC valve is stuck fully open if it does not operate when the main switch is turned "OFF". (Touch the ISC unit with your hand and check if it is vibrating to confirm if the ISC valve is operating.) 	
4	ISC valve is not moving correctly.	<ul style="list-style-type: none"> • Execute the diagnostic mode. (Code No. d54) • After the ISC valve is fully closed, it opens to the standby opening position when the engine is started. This operation takes approximately 12 seconds. Start the engine. If the error recurs, replace the throttle body assembly. 	

FUEL INJECTION SYSTEM

Fault code No.	39	Symptom	Fuel injector: open or short circuit detected.	
Diagnostic code No.	d36	Fuel injector		
Order	Item/components and probable cause		Check or maintenance job	Reinstatement method
1	Connections <ul style="list-style-type: none"> • Fuel injector coupler • Main wire harness-ECU coupler • Main wire harness fuel pump coupler 		<ul style="list-style-type: none"> • Check the couplers for any pins that may have pulled out. • Check the locking condition of the couplers. • If there is a malfunction, repair it and connect the coupler securely. 	Cranking the engine. (Connect the fuel injector coupler.)
2	Open or short circuit in wire harness.		<ul style="list-style-type: none"> • Repair or replace if there is an open or short circuit. • Between fuel injector coupler and ECU coupler. (red/black–red/black) (red/blue–red/blue) 	
3	Defective fuel injector.		<ul style="list-style-type: none"> • Execute the diagnostic mode. (Code No. d36) • Replace if defective. Refer to “CHECKING THE INJECTOR” on page 7-6. 	

Fault code No.	41	Symptom	Lean angle sensor: open or short circuit detected.	
Diagnostic code No.	d08	Lean angle sensor		
Order	Item/components and probable cause		Check or maintenance job	Reinstatement method
1	Connections <ul style="list-style-type: none"> • Lean angle sensor coupler • Main wire harness-ECU coupler 		<ul style="list-style-type: none"> • Check the coupler for any pins that may have pulled out. • Check the locking condition of the coupler. • If there is a malfunction, repair it and connect the coupler securely. 	Setting the main switch to “ON”.
2	Open or short circuit in wire harness.		<ul style="list-style-type: none"> • Repair or replace if there is an open or short circuit. • Between lean angle sensor coupler and ECU coupler. (black/blue–black/blue) (yellow/green–yellow/green) (blue–blue) 	
3	Defective lean angle sensor		<ul style="list-style-type: none"> • Execute the diagnostic mode. (Code No. d08) • Replace if defective. Refer to “CHECKING THE LEAN ANGLE SENSOR” on page 9-91 	

FUEL INJECTION SYSTEM

Fault code No.	42	Symptom	No normal signals are received from the speed sensor.	
Diagnostic code No.	d07	Speed sensor		
Order	Item/components and probable cause	Check or maintenance job	Reinstatement method	
1	Connections <ul style="list-style-type: none"> • Speed sensor coupler • Main wire harness-ECU coupler 	<ul style="list-style-type: none"> • Check the coupler for any pins that may have pulled out. • Check the locking condition of the coupler. • If there is a malfunction, repair it and connect the coupler securely. 	Starting the engine, and activating the vehicle speed sensor by operating the vehicle at 20 to 30 km/h.	
2	Open or short circuit in speed sensor lead.	<ul style="list-style-type: none"> • Repair or replace if there is an open or short circuit. • Between speed sensor coupler and ECU coupler. (blue–blue) (white–white) (black/blue–black/blue) 		
3	Gear for detecting vehicle speed has broken.	<ul style="list-style-type: none"> • Replace if defective. Refer to “TRANSMISSION” on page 5-71. 		
4	Defective speed sensor	<ul style="list-style-type: none"> • Execute the diagnostic mode. (Code No. d07) • Replace if defective. Refer to “CHECKING THE SPEED SENSOR” on page 9-94. 		

FUEL INJECTION SYSTEM

Fault code No.	43	Symptom	Power supply to the fuel injector and fuel pump is not normal.	
Diagnostic code No.		d09	Fuel system voltage	
Order	Item/components and probable cause		Check or maintenance job	Reinstatement method
1	Connections <ul style="list-style-type: none"> • Fuel injection system relay • Main wire harness-ECU coupler 		<ul style="list-style-type: none"> • Check the coupler for any pins that may have pulled out. • Check the locking condition of the coupler. • If there is a malfunction, repair it and connect the coupler securely. 	Starting the engine and operating it at idle.
2	Open or short circuit in the wire harness.		<ul style="list-style-type: none"> • Repair or replace if there is an open or short circuit. • Between fuel injection system relay coupler and ECU coupler. (blue/red–blue/red) (red/blue–red/blue) • Between fuel injection system relay coupler and starter relay coupler. (brown/black–brown/black) • Between fuel injection system relay coupler and left handlebar switch coupler. (red/black–red/black) 	
3	Malfunction or open circuit in fuel injection system relay		<ul style="list-style-type: none"> • Execute the diagnostic mode. (Code No. d09) • Replace if defective. • If there is no malfunction with the fuel injection system relay, replace the ECU. 	

Fault code No.	44	Symptom	Error is detected while reading or writing on EEPROM (CO adjustment value).	
Diagnostic code No.		d60	EEPROM improper cylinder indication	
Order	Item/components and probable cause		Check or maintenance job	Reinstatement method
1	Malfunction in ECU.		<ul style="list-style-type: none"> • Execute the diagnostic mode. (Code No. d60) • If "01" is displayed, read just the CO. (for Europe and Oceania) Refer to "ADJUSTING THE EXHAUST GAS VOLUME (for Europe and Oceania)" on page 3-6. • Replace the ECU if defective. 	Setting the main switch to "ON".

FUEL INJECTION SYSTEM

Fault code No.	46	Symptom	Power supply to the fuel injection system is not normal.	
Diagnostic code No.		—	—	
Order	Item/components and probable cause	Check or maintenance job		Reinstatement method
1	Connections • Main wire harness-ECU coupler	<ul style="list-style-type: none"> • Check the coupler for any pins that may have pulled out. • Check the locking condition of the coupler. • If there is a malfunction, repair it and connect the coupler securely. 		Starting the engine and operating it at idle.
2	Faulty battery.	<ul style="list-style-type: none"> • Charge or replace the battery. Refer to “CHECKING AND CHARGING THE BATTERY” on page 9-84. 		
3	Malfunction in rectifier/regulator.	<ul style="list-style-type: none"> • Replace if defective. Refer to “CHARGING SYSTEM” on page 9-11. 		
4	Open or short circuit in the wire harness.	<ul style="list-style-type: none"> • Repair or replace if there is an open or short circuit. • Between battery and main switch coupler (red–red) • Between main switch coupler and ignition fuse (brown/blue–brown/blue) • Between ignition fuse and ECU coupler (brown–brown) 		

Fault code No.	50	Symptom	Faulty ECU memory. (When this malfunction is detected in the ECU, the fault code number might not appear on the meter.)	
Diagnostic code No.		—	—	
Order	Item/components and probable cause	Check or maintenance job		Reinstatement method
1	Malfunction in ECU	Replace the ECU. TIP _____ Do not perform this procedure with the main switch turned to “ON”. _____		Setting the main switch to “ON”.

EAS27550

FUEL PUMP SYSTEM

EAS27560

CIRCUIT DIAGRAM

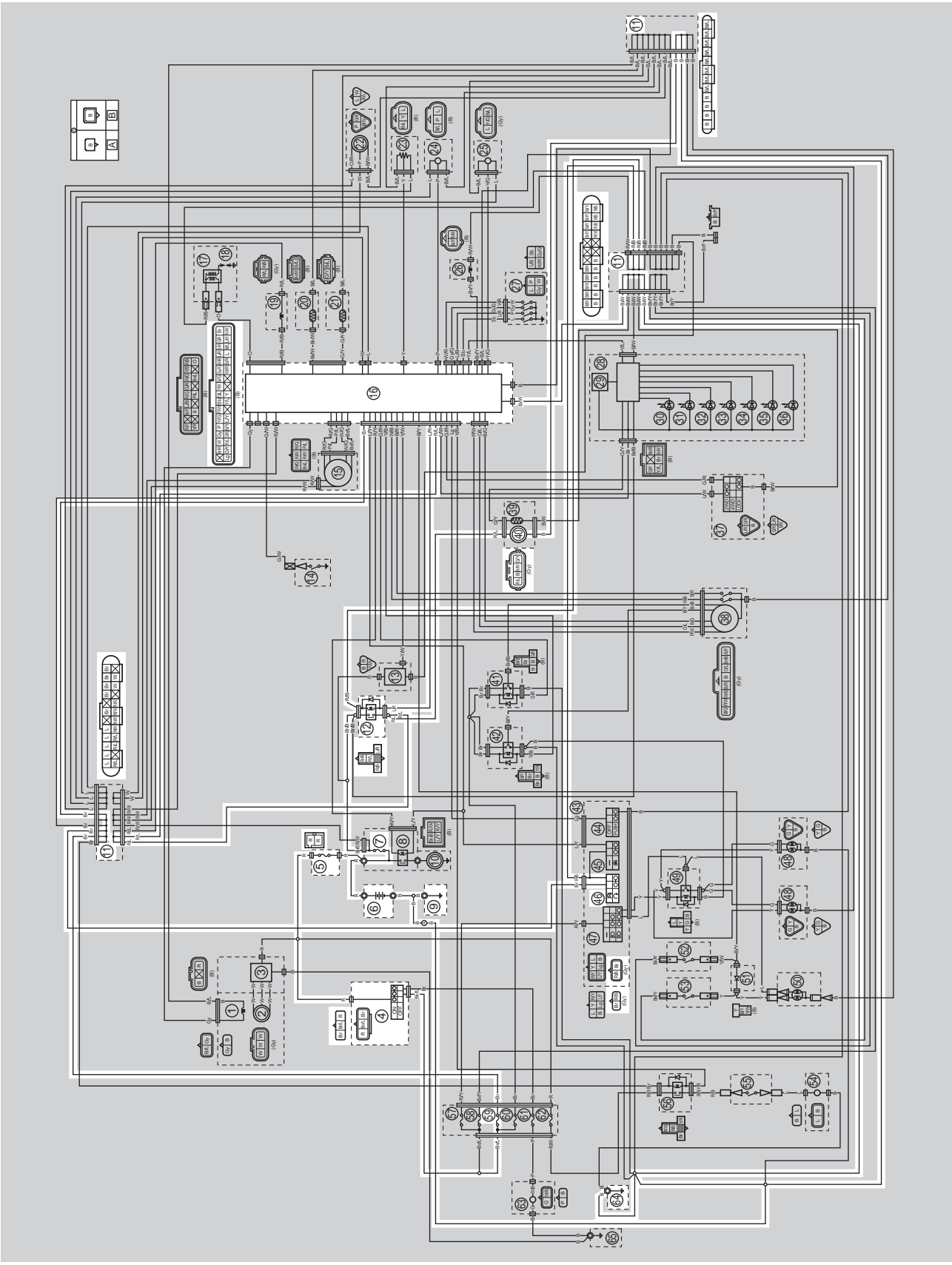

FUEL PUMP SYSTEM

- 4. Main switch
 - 5. Main fuse
 - 6. Battery
 - 7. Fuel injection system fuse
 - 9. Engine ground
 - 11. Joint coupler
 - 12. Fuel injection system relay
 - 16. ECU (engine control unit)
 - 40. Fuel pump
 - 46. Engine stop switch
 - 59. Ignition fuse
 - 64. Frame ground 1
-
- A. Wire harness
 - B. Negative battery sub-wire harness

EAS27570

TROUBLESHOOTING

If the fuel pump fails to operate.

TIP

• Before troubleshooting, remove the following part(s):

1. Seat
2. Battery cover
3. Rear fender

<p>1. Check the fuses. (Main, ignition and fuel injection system) Refer to "CHECKING THE FUSES" on page 9-83.</p>	<p>NG →</p>	<p>Replace the fuse(s).</p>
<p>OK ↓</p>		
<p>2. Check the battery. Refer to "CHECKING AND CHARGING THE BATTERY" on page 9-84.</p>	<p>NG →</p>	<ul style="list-style-type: none"> • Clean the battery terminals. • Recharge or replace the battery.
<p>OK ↓</p>		
<p>3. Check the main switch. Refer to "CHECKING THE SWITCHES" on page 9-79.</p>	<p>NG →</p>	<p>Replace the main switch.</p>
<p>OK ↓</p>		
<p>4. Check the engine stop switch. Refer to "CHECKING THE SWITCHES" on page 9-79.</p>	<p>NG →</p>	<p>The engine stop switch is faulty. Replace the left handlebar switch.</p>
<p>OK ↓</p>		
<p>5. Check the fuel injection system relay. Refer to "CHECKING THE RELAYS" on page 9-87.</p>	<p>NG →</p>	<p>Replace the fuel injection system relay.</p>
<p>OK ↓</p>		
<p>6. Check the fuel pump. Refer to "CHECKING THE FUEL PUMP BODY" on page 7-2.</p>	<p>NG →</p>	<p>Replace the fuel pump.</p>
<p>OK ↓</p>		
<p>7. Check the entire fuel pump system wiring. Refer to "CIRCUIT DIAGRAM" on page 9-57.</p>	<p>NG →</p>	<p>Properly connect or repair the fuel pump system wiring.</p>
<p>OK ↓</p>		
<p>Replace the ECU.</p>		

2WD/4WD SELECTING SYSTEM

EAS30200

2WD/4WD SELECTING SYSTEM

EAS30210

CIRCUIT DIAGRAM

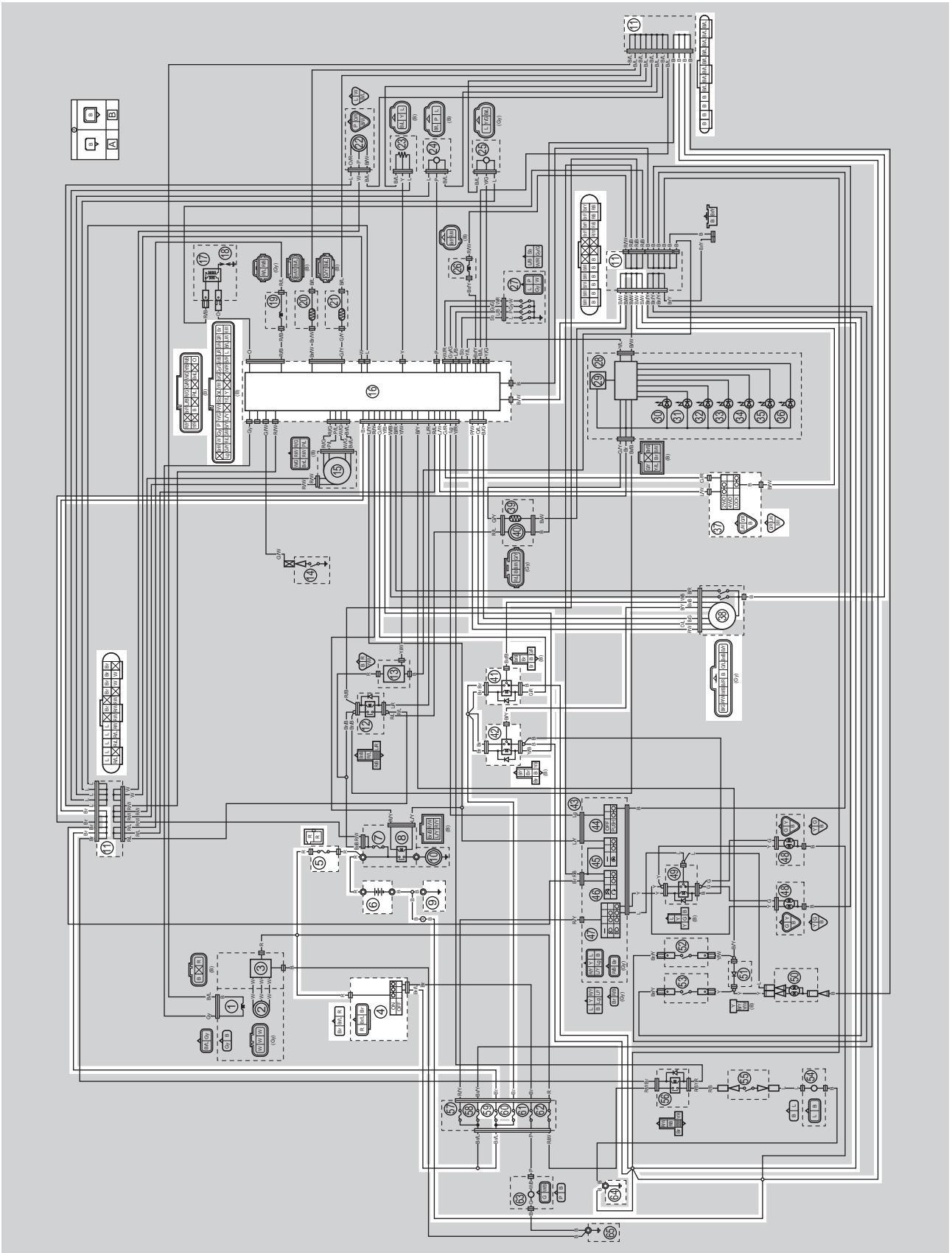

2WD/4WD SELECTING SYSTEM

- 4. Main switch
- 5. Main fuse
- 6. Battery
- 9. Engine ground
- 11. Joint coupler
- 16. ECU (engine control unit)
- 37. On-command four-wheel-drive motor switch
and differential lock switch
- 38. Differential motor
- 41. Four-wheel-drive motor relay 1
- 42. Four-wheel-drive motor relay 2
- 59. Ignition fuse
- 60. Four-wheel-drive motor fuse
- 64. Frame ground 1

- A. Wire harness
- B. Negative battery sub-wire harness

2WD/4WD SELECTING SYSTEM

EAS30220

TROUBLESHOOTING

The four-wheel-drive motor indicator light fails to come on.

TIP

• Before troubleshooting, remove the following part(s):

1. Seat
2. Battery cover

1. Check the fuses. (Main, Ignition and four-wheel-drive motor) Refer to "CHECKING THE FUSES" on page 9-83.	NG →	Replace the fuse(s).
OK ↓		
2. Check the battery. Refer to "CHECKING AND CHARGING THE BATTERY" on page 9-84.	NG →	<ul style="list-style-type: none">• Clean the battery terminals.• Recharge or replace the battery.
OK ↓		
3. Check the main switch. Refer to "CHECKING THE SWITCHES" on page 9-79.	NG →	Replace the main switch.
OK ↓		
4. Check the on-command four-wheel-drive motor switch and differential lock switch. Refer to "CHECKING THE SWITCHES" on page 9-79.	NG →	Replace the on-command four-wheel-drive motor switch and differential lock switch.
OK ↓		
5. Check the four-wheel-drive motor relay 1. Refer to "CHECKING THE RELAYS" on page 9-87.	NG →	Replace the four-wheel-drive motor relay 1.
OK ↓		
6. Check the four-wheel-drive motor relay 2. Refer to "CHECKING THE RELAYS" on page 9-87.	NG →	Replace the four-wheel-drive motor relay 2.
OK ↓		
7. Check the differential motor. Refer to "CHECKING THE DIFFERENTIAL MOTOR" on page 8-11.	NG →	Replace the differential motor.
OK ↓		

2WD/4WD SELECTING SYSTEM

8. Check the entire 2WD/4WD selecting system wiring.
Refer to "CIRCUIT DIAGRAM" on page 9-61.

NG →

Properly connect or repair the 2WD/4WD selecting system wiring.

OK ↓

Replace the ECU.

EPS (ELECTRIC POWER STEERING) SYSTEM (for EPS models)

EAS1HPG017

EPS (ELECTRIC POWER STEERING) SYSTEM (for EPS models)

EAS30240

CIRCUIT DIAGRAM

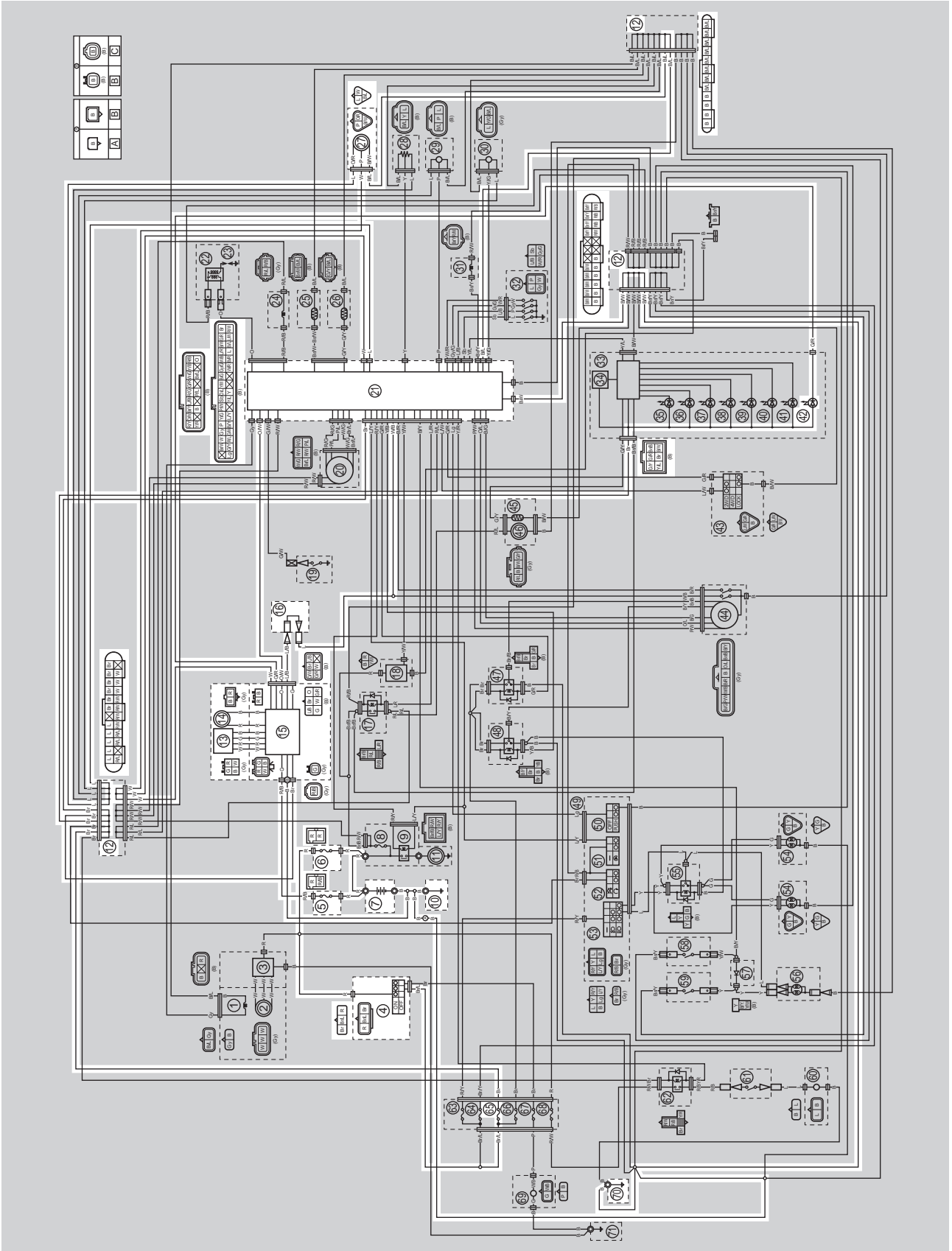

EPS (ELECTRIC POWER STEERING) SYSTEM (for EPS models)

- 4. Main switch
 - 5. EPS fuse
 - 6. Main fuse
 - 7. Battery
 - 10.Engine ground
 - 12.Joint coupler
 - 13.EPS torque sensor
 - 14.EPS motor
 - 15.EPS (electric power steering) control unit
 - 16.EPS self-diagnosis signal connectors
 - 21.ECU (engine control unit)
 - 27.Speed sensor
 - 42.EPS warning light
 - 65.Ignition fuse
 - 70.Frame ground 1
-
- A. Wire harness
 - B. Negative battery sub-wire harness
 - C. EPS (electric power steering) control unit

EPS (ELECTRIC POWER STEERING) SYSTEM (for EPS models)

EAS30250

EPS CONTROL UNIT'S SELF-DIAGNOSTIC FUNCTION

The EPS control unit is equipped with a self-diagnostic function. If this function detects a malfunction in the EPS system, it lights the EPS warning light to alert the rider that a malfunction has occurred in the system. Once a malfunction has been detected, it becomes stored in the EPS control unit memory in the form of a fault code.

- The EPS warning light comes on when the main switch is set to “ON”, and then goes off once the engine is started. If the warning light remains on or comes on after the engine is started, the EPS system may be defective.
- The electrical circuit of the warning light can be checked by setting the main switch to “ON”. If the warning light does not come on, the electrical circuit may be defective.



1. EPS warning light

TIP

- If the engine is stopped using the engine stop switch and the main switch is in the “ON” position, the EPS warning light comes on to indicate that the power assistance for the steering is not functioning.
 - If the steering usage is too heavy (i.e., excessive steering use when the vehicle is traveling at a slow speed), the power assist is reduced to protect the EPS motor from overheating.
-

EAS30260

EPS WARNING LIGHT DURING NORMAL OPERATION

The EPS warning light comes on initially for 2 seconds after the main switch is set to “ON”. However, the warning light remains on until the engine is started.

In addition, if a malfunction is detected while the warning light comes on initially, the warning light remains on.

Furthermore, the warning light comes on whenever a malfunction has occurred.

TIP

The EPS system does not operate while the EPS warning light is on.

EPS (ELECTRIC POWER STEERING) SYSTEM (for EPS models)

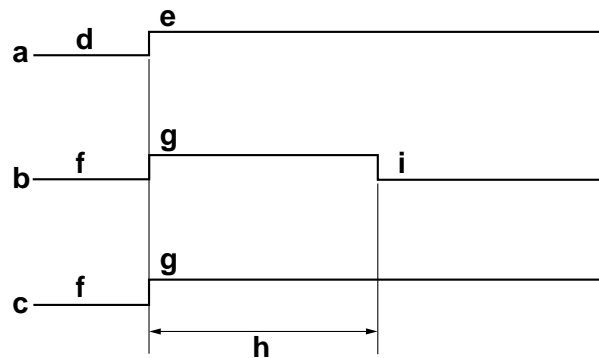

- | | |
|--|--------------------------------|
| a. Main switch | f. Off |
| b. EPS warning light (no malfunction detected) | g. Comes on. |
| c. EPS warning light (malfunction detected) | h. Initial lighting: 2 seconds |
| d. OFF | i. Goes off. |
| e. ON | |

EAS30270

DIAGNOSTIC MODE

Setting the diagnostic mode (present and past malfunctions)

1. Set the main switch to "ON".
2. Disconnect the EPS self-diagnosis signal connector "1".
3. Select the signaling mode by grounding the EPS self-diagnosis signal connector (male side) to the EPS control unit "2" or disconnecting it from the unit as follows.

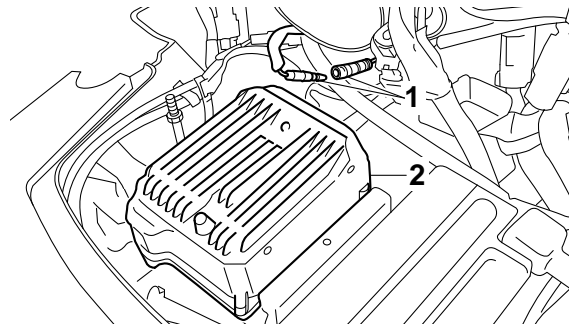

- Present malfunction signaling mode
Ground the EPS self-diagnosis signal connector within 5 seconds after setting the main switch to "ON", and leave it grounded. The signaling mode is activated after 5 seconds.
 - Past malfunction signaling mode
While the present malfunction mode is activated, briefly disconnect the EPS self-diagnosis signal connector, ground it again, and leave it grounded. The signaling mode is activated after 5 seconds.
4. Set the main switch to "OFF" to cancel the diagnostic mode.

TIP

- The diagnostic mode can also be canceled by riding the vehicle at speeds above 2 km/h (1.2 mi/h).
- When the diagnostic mode is selected and during the initial lighting of the EPS warning light, the EPS control unit does not receive input from the EPS self-diagnosis signal connector.

5. Connect the EPS self-diagnosis signal connector.

EPS (ELECTRIC POWER STEERING) SYSTEM (for EPS models)

Identifying fault codes

When the diagnostic mode is activated, the fault codes determined by the fail-safe specifications are signaled by the EPS warning light as follows.

- Present malfunction signaling mode: Currently detected fault codes are signaled.
- Past malfunction signaling mode: Both previously detected fault codes and currently detected fault codes are signaled.

Signaling method

Example 1: Fault code No. 23

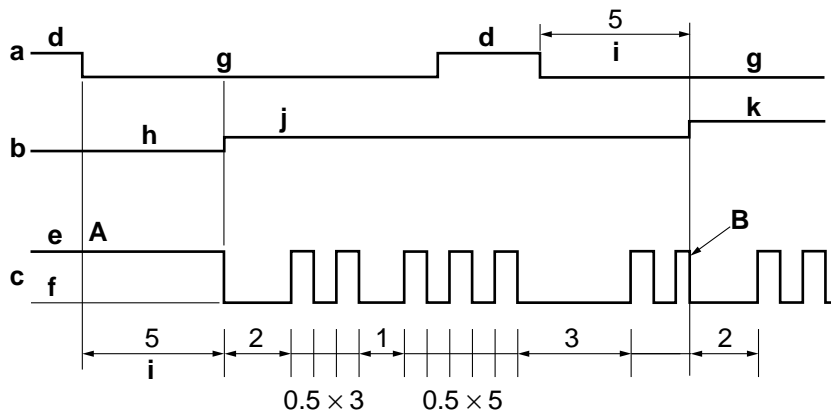

- | | |
|--|--|
| a. EPS self-diagnosis signal connector | i. Mode selection judgment |
| b. Diagnostic mode | j. Present malfunction signaling mode |
| c. EPS warning light | k. Past malfunction signaling mode |
| d. Disconnected | |
| e. On | A. The EPS warning light comes on for 5 seconds during the diagnostic mode selection judgment. |
| f. Off | B. Display of the present malfunctions stops when the past malfunction display mode is selected. |
| g. Grounded | |
| h. Normal mode (diagnostic mode not activated) | |

After the mode selection judgment is completed (present or past malfunction mode), the current fault code signaling stops immediately, and then the first code of the mode is signaled 2 seconds later. When a fault code is signaled, the EPS warning light goes off for 1 second between the units of 10 and the units of 1 for the code. After a fault code is signaled, the warning light goes off for 3 seconds, and then the next code is signaled.

Example 2: No malfunctions are detected

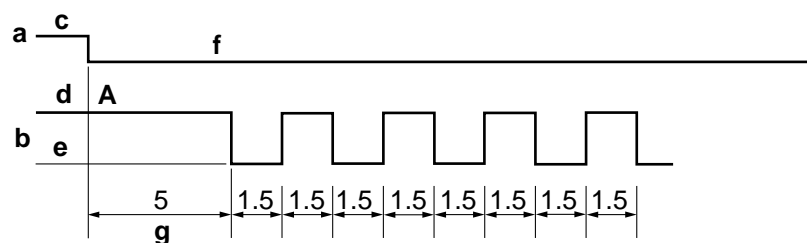

- | | |
|--|--|
| a. EPS self-diagnosis signal connector | g. Mode selection judgment |
| b. EPS warning light | |
| c. Disconnected | A. The EPS warning light comes on for 5 seconds during the diagnostic mode selection judgment. |
| d. Comes on. | |
| e. Goes off. | |
| f. Grounded | |

EPS (ELECTRIC POWER STEERING) SYSTEM (for EPS models)

Fault code No.	Item	Symptom	Probable cause of malfunction
53	EPS control unit	Battery voltage has dropped.	<ul style="list-style-type: none"> Faulty battery. Malfunction in the charging system. Refer to "CHARGING SYSTEM" on page 9-11. Malfunction in EPS control unit.
54	EPS control unit	Relay contacts in the EPS control unit are welded together.	Malfunction in EPS control unit.
55	EPS control unit	Battery voltage has increased. Abnormality exists between the EPS and the ECU.	<ul style="list-style-type: none"> Malfunction in the charging system. Refer to "CHARGING SYSTEM" on page 9-11. Malfunction in EPS control unit.

EAS30290

TROUBLESHOOTING DETAILS (EPS SYSTEM)

TIP

The malfunction history is stored even if the main switch is turned to "OFF", therefore, be sure to erase the history (present and past malfunction signaling modes) after repairing the cause of the EPS system malfunction. The malfunction history must be erased in the diagnostic mode. Refer to "DIAGNOSTIC MODE" on page 9-68.

Fault code No.	11,13,15,16	Symptom	EPS torque sensor: open or short circuit detected.	
Order	Item/components and probable cause		Check or maintenance job	Reinstatement method
1	Connections • EPS torque sensor coupler		<ul style="list-style-type: none"> Check the coupler for any pins that may have pulled out. Check the locking condition of the coupler. If there is a malfunction, repair it and connect the coupler securely. 	Setting the main switch to "OFF".
2	Defective EPS torque sensor.		<ul style="list-style-type: none"> Replace if defective. Refer to "CHECKING THE EPS TORQUE SENSOR (for EPS models)" on page 9-98. 	
3	Open or short circuit in EPS torque sensor lead.		<ul style="list-style-type: none"> Repair or replace if there is an open or short circuit. Between EPS torque sensor coupler and EPS control unit coupler. (white–white) (red–red) (green–green) (black–black) 	

EPS (ELECTRIC POWER STEERING) SYSTEM (for EPS models)

Fault code No.	21	Symptom	Speed sensor: open or short circuit detected.	
Order	Item/components and probable cause	Check or maintenance job	Reinstatement method	
1	Connections <ul style="list-style-type: none"> • Speed sensor coupler • EPS control unit coupler at the wire harness 	<ul style="list-style-type: none"> • Check the coupler for any pins that may have pulled out. • Check the locking condition of the coupler. • If there is a malfunction, repair it and connect the coupler securely. 	Starting the engine and activating the vehicle speed sensor by operating the vehicle above 5 km/h (3 mi/h), or setting the main switch to "OFF", then to "ON", and then deleting the fault codes. Refer to "DIAGNOSTIC MODE" on page 9-68.	
2	Open or short circuit in wire harness.	<ul style="list-style-type: none"> • Repair or replace if there is an open or short circuit. • Between speed sensor coupler and EPS control unit coupler. (white-white) 		
3	Defective speed sensor.	<ul style="list-style-type: none"> • Execute the diagnostic mode. (Code No. 21) • Replace if defective. Refer to "CHECKING THE SPEED SENSOR" on page 9-94. 		

Fault code No.	22	Symptom	No normal signals are received from the ECU.	
Order	Item/components and probable cause	Check or maintenance job	Reinstatement method	
1	Connections <ul style="list-style-type: none"> • EPS control unit coupler at the wire harness • ECU coupler at the wire harness 	<ul style="list-style-type: none"> • Check the coupler for any pins that may have pulled out. • Check the locking condition of the coupler. • If there is a malfunction, repair it and connect the coupler securely. 	Setting the main switch to "OFF".	
2	Open or short circuit in wire harness.	<ul style="list-style-type: none"> • Repair or replace if there is an open or short circuit. • Between ECU coupler and EPS control unit coupler. (orange/white-orange/white) 		
3	Malfunction in ECU.	Replace the ECU.		

EPS (ELECTRIC POWER STEERING) SYSTEM (for EPS models)

Fault code No.	41,42, 43,45	Symptom	EPS motor: open or short circuit detected.	
Order	Item/components and probable cause	Check or maintenance job	Reinstatement method	
1	Connections • EPS motor coupler	<ul style="list-style-type: none"> • Check the coupler for any pins that may have pulled out. • Check the locking condition of the coupler. • If there is a malfunction, repair it and connect the coupler securely. 	Setting the main switch to "OFF".	
2	Open or short circuit in EPS motor lead.	<ul style="list-style-type: none"> • Repair or replace if there is an open or short circuit. • Between EPS motor and EPS control unit coupler. (red–red) (black–black) 		
3	Defective EPS motor.	Replace if defective. Refer to "CHECKING THE EPS MOTOR (for EPS models)" on page 9-97.		

Fault code No.	52	Symptom	Relay contacts in the EPS control unit are welded together.	
Order	Item/components and probable cause	Check or maintenance job	Reinstatement method	
1	Malfunction in EPS control unit.	Replace the EPS control unit.	Setting the main switch to "OFF".	

Fault code No.	53	Symptom	Power supply to the EPS control unit is not normal (low battery voltage).	
Order	Item/components and probable cause	Check or maintenance job	Reinstatement method	
1	Faulty battery.	Charge or replace the battery. Refer to "CHECKING AND CHARGING THE BATTERY" on page 9-84.	Setting the main switch to "OFF".	
2	Malfunction in rectifier/regulator or charging system.	Replace if defective. Refer to "CHECKING THE RECTIFIER/REGULATOR" on page 9-93.		
3	Malfunction in EPS control unit.	Replace the EPS control unit.		

EPS (ELECTRIC POWER STEERING) SYSTEM (for EPS models)

Fault code No.	54	Symptom	Relay contacts in the EPS control unit are welded together.	
Order	Item/components and probable cause		Check or maintenance job	Reinstatement method
1	Malfunction in EPS control unit.		Replace the EPS control unit.	Setting the main switch to "OFF".

Fault code No.	55	Symptom	Power supply to the EPS control unit is not normal (high battery voltage). Malfunction in control unit.	
Order	Item/components and probable cause		Check or maintenance job	Reinstatement method
1	Faulty battery.		Replace the battery. Refer to "CHECKING AND CHARGING THE BATTERY" on page 9-84.	Setting the main switch to "OFF".
2	Malfunction in rectifier/regulator.		Replace if defective. Refer to "CHECKING THE RECTIFIER/REGULATOR" on page 9-93.	
3	Malfunction in EPS control unit.		Replace the EPS control unit.	

ELECTRICAL COMPONENTS

EAS27972

ELECTRICAL COMPONENTS

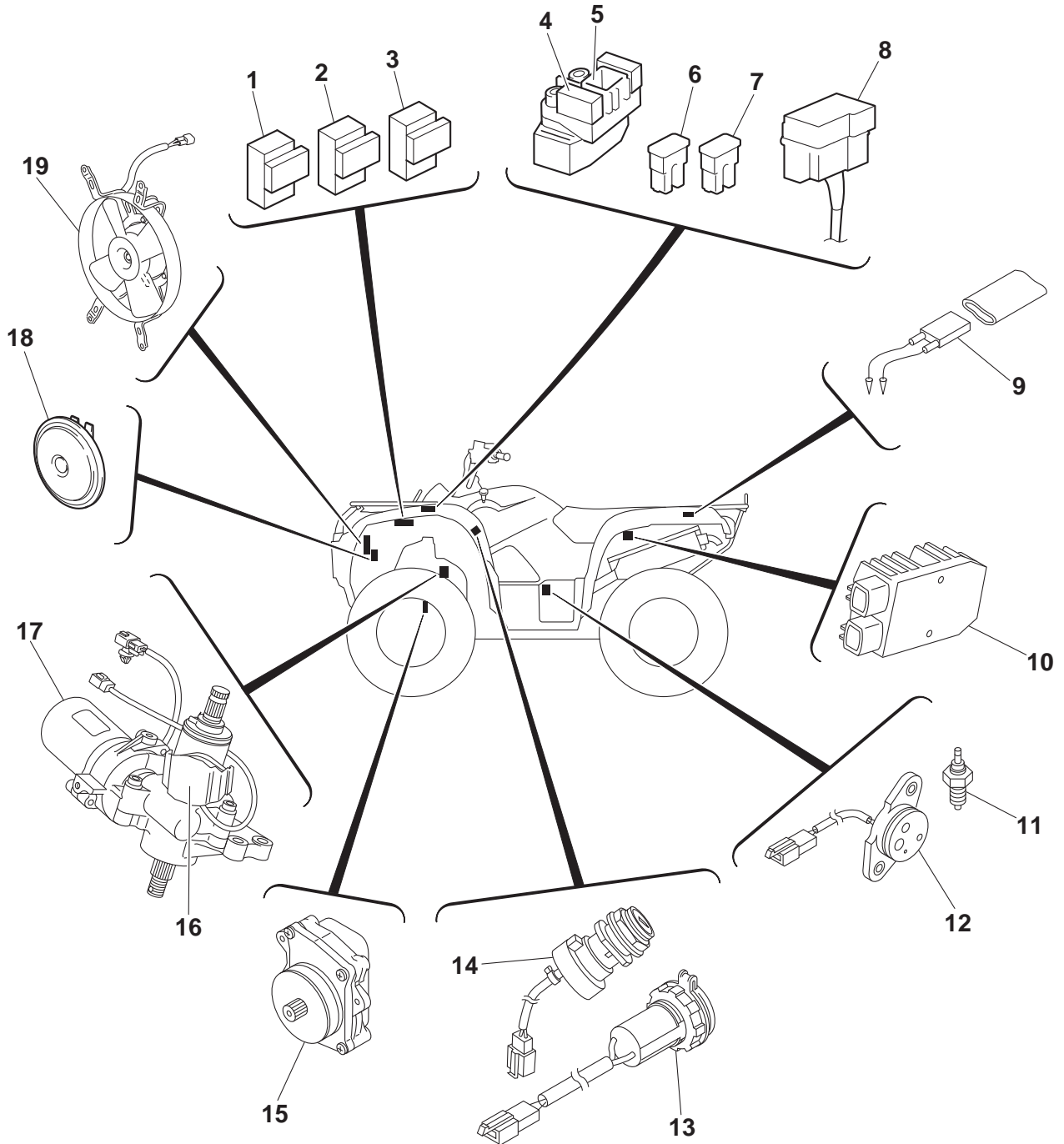

ELECTRICAL COMPONENTS

1. Four-wheel-drive motor relay 1
2. Four-wheel-drive motor relay 2
3. Headlight relay
4. Fuel injection system fuse
5. Starter relay
6. EPS fuse (for EPS models)
7. Main fuse
8. Fuse box (ignition, headlights, four-wheel-drive motor, radiator fan motor, signaling system, auxiliary DC jack)
9. Radiator fan motor circuit breaker
10. Rectifier/regulator
11. Reverse switch
12. Gear position switch
13. Auxiliary DC jack
14. Main switch
15. Differential motor
16. EPS torque sensor (for EPS models)
17. EPS motor (for EPS models)
18. Horn (for Europe and Oceania)
19. Radiator fan motor

ELECTRICAL COMPONENTS

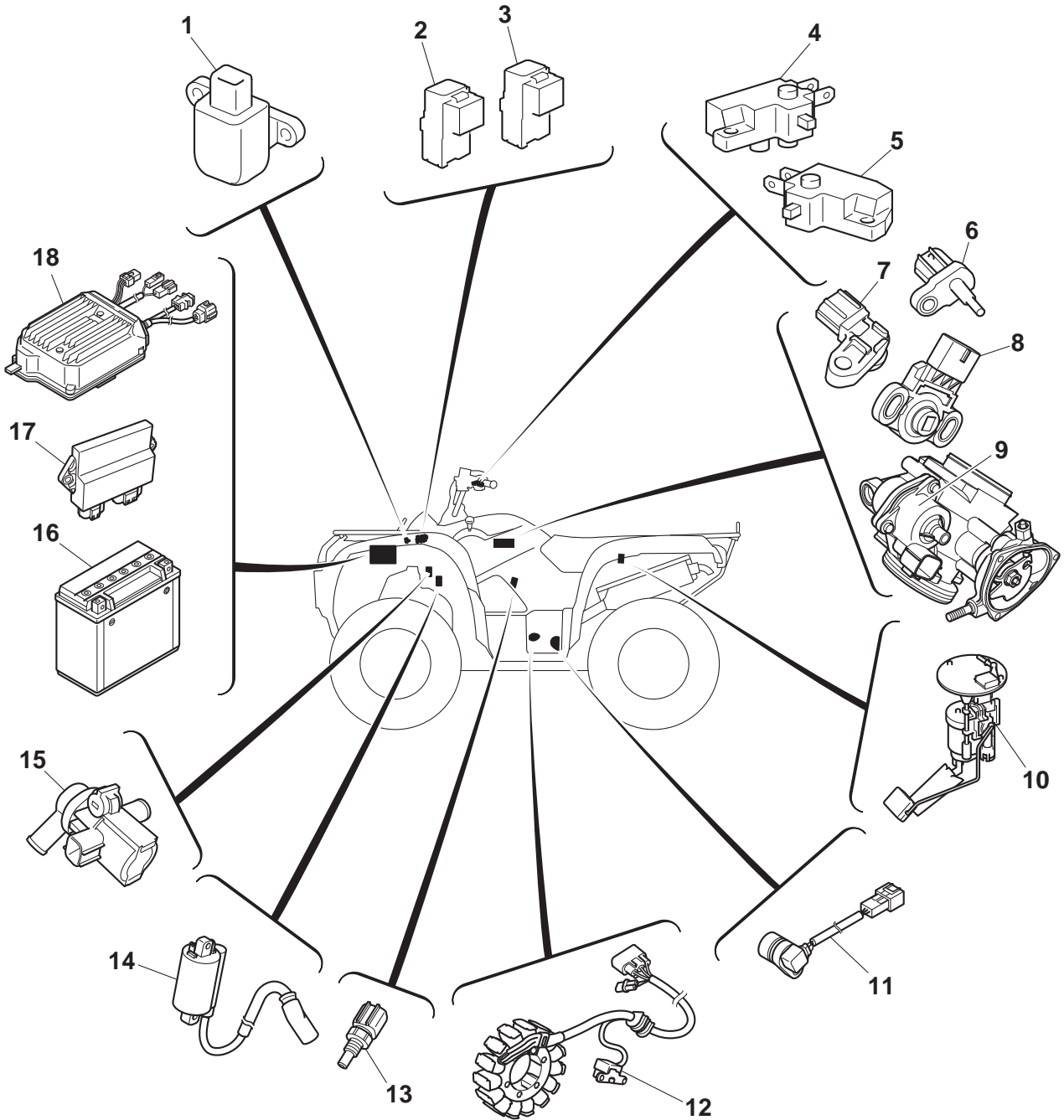

ELECTRICAL COMPONENTS

1. Lean angle sensor
2. Radiator fan motor relay
3. Fuel injection system relay
4. Front brake light switch
5. Rear brake light switch
6. Intake air temperature sensor
7. Intake air pressure sensor
8. TPS (throttle position sensor)
9. ISC (idle speed control) unit
10. Fuel pump
11. Speed sensor
12. Crankshaft position sensor
13. Coolant temperature sensor
14. Ignition coil
15. Air induction system solenoid
16. Battery
17. ECU (engine control unit)
18. EPS (electric power steering) control unit (for EPS models)

ELECTRICAL COMPONENTS

EAS27980

CHECKING THE SWITCHES

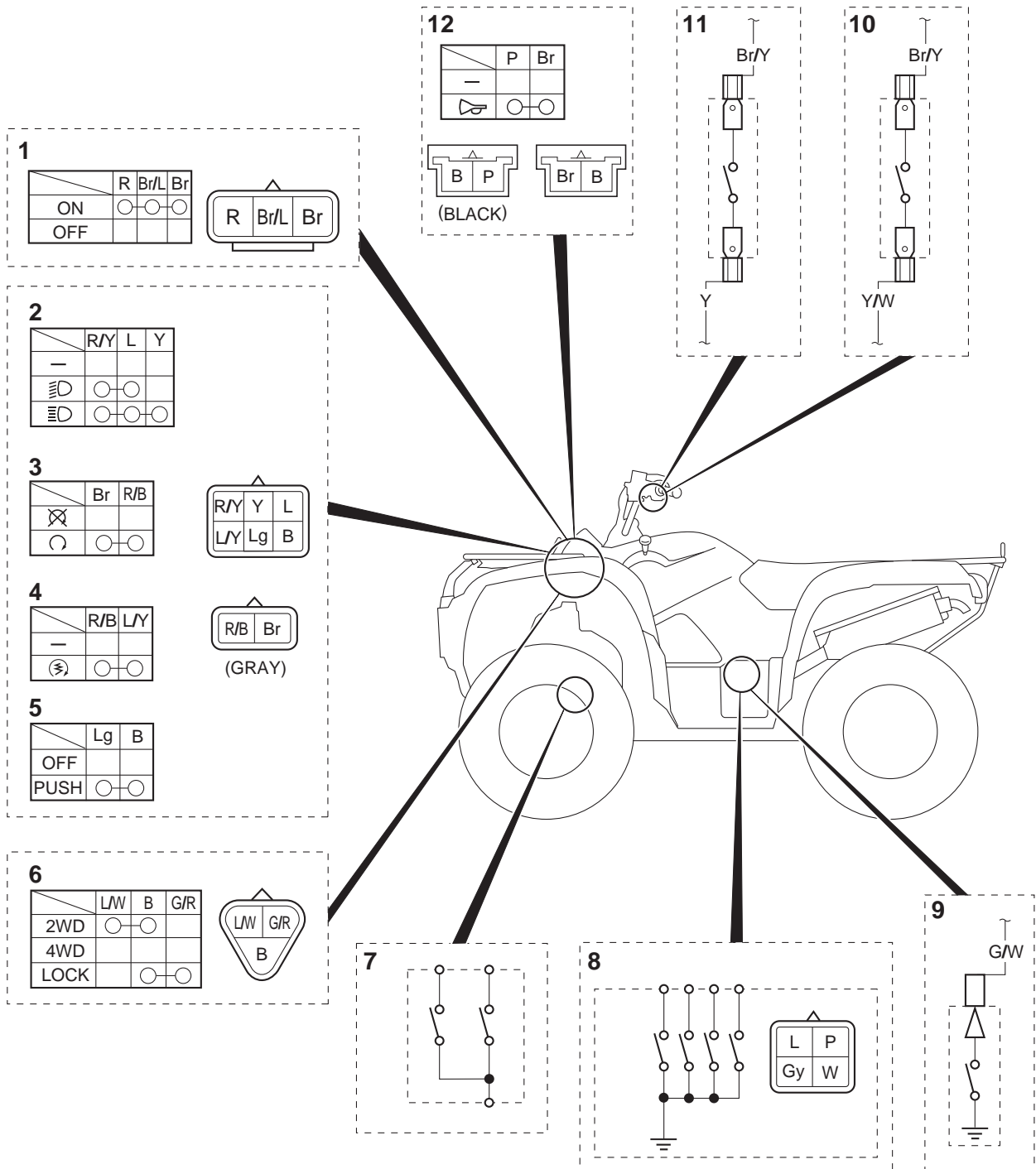

ELECTRICAL COMPONENTS

1. Main switch
2. Light switch
3. Engine stop switch
4. Start switch
5. Override switch
6. On-command four-wheel-drive motor switch and differential gear lock switch
7. Four-wheel-drive motor switch (differential motor)
8. Gear position switch
9. Reverse switch
10. Rear brake light switch
11. Front brake light switch
12. Horn switch (for Europe and Oceania)

ELECTRICAL COMPONENTS

Check each switch for continuity with the pocket tester. If the continuity reading is incorrect, check the wiring connections and if necessary, replace the switch.

ECA14370

NOTICE

Never insert the tester probes into the coupler terminal slots "a". Always insert the probes from the opposite end of the coupler, taking care not to loosen or damage the leads.



Pocket tester
90890-03112
Analog pocket tester
YU-03112-C

TIP

- Before checking for continuity, set the pocket tester to "0" and to the " $\Omega \times 1$ " range.
- When checking for continuity, switch back and forth between the switch positions a few times.

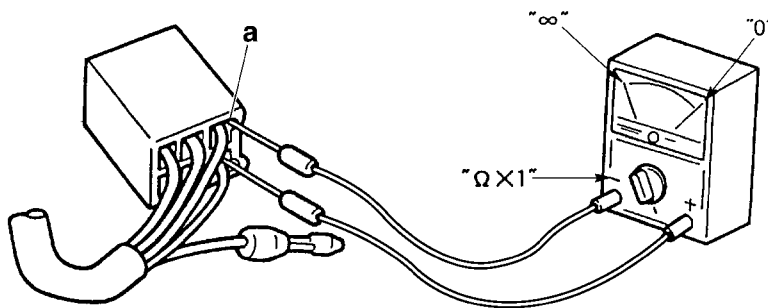

The switches and their terminal connections are illustrated as in the following example of the main switch.

The switch positions "a" are shown in the far left column and the switch lead colors "b" are shown in the top row.

The continuity (i. e., a closed circuit) between switch terminals at a given switch position is indicated by "○—○". There is continuity between red, brown/blue, and brown when the switch is set to "ON".

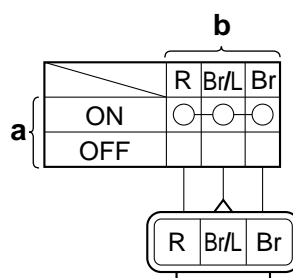

EAS27990

CHECKING THE BULBS AND BULB SOCKETS

TIP

Do not check any of the lights that use LEDs.

Check each bulb and bulb socket for damage or wear, proper connections, and also for continuity between the terminals.

Damage/wear → Repair or replace the bulb, bulb socket or both.

Improperly connected → Properly connect.

No continuity → Repair or replace the bulb, bulb socket or both.

Types of bulbs

The bulbs used on this vehicle are shown in the illustration.

- Bulbs “a” and “b” are used for the headlights and usually use a bulb holder that must be detached before removing the bulb. The majority of these types of bulbs can be removed from their respective sockets by turning them counterclockwise.
- Bulbs “c” are used for tail/brake lights and can be removed from the socket by pushing and turning the bulb counterclockwise.

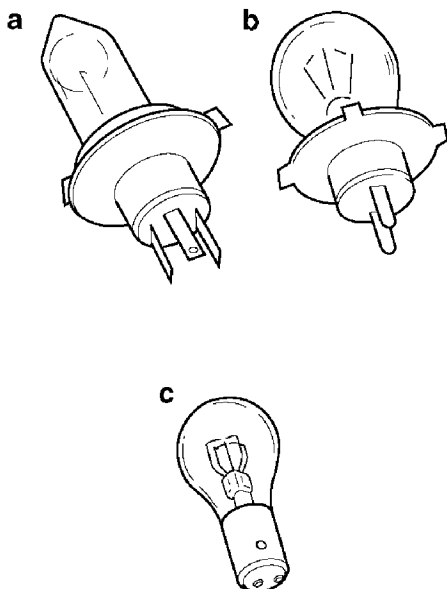

Checking the condition of the bulbs

The following procedure applies to all of the bulbs.

1. Remove:
 - Bulb

EWA28P1001

WARNING

Since headlight bulbs get extremely hot, keep flammable products and your hands away from them until they have cooled down.

ECA28P1001

NOTICE

- Be sure to hold the socket firmly when removing the bulb. Never pull the lead, otherwise it may be pulled out of the terminal in the coupler.
- Avoid touching the glass part of a headlight bulb to keep it free from oil, otherwise the transparency of the glass, the life of the bulb, and the luminous flux will be adversely affected. If the headlight bulb gets soiled, thoroughly clean it with a cloth moistened with alcohol or lacquer thinner.

2. Check:

- Bulb (for continuity)
(with the pocket tester)
No continuity → Replace.



Pocket tester
90890-03112
Analog pocket tester
YU-03112-C

TIP

Before checking for continuity, set the pocket tester to “0” and to the “Ω × 1” range.

- a. Connect the positive tester probe to terminal “1” and the negative tester probe to terminal “2”, and check the continuity.
- b. Connect the positive tester probe to terminal “1” and the negative tester probe to terminal “3”, and check the continuity.
- c. If either of the readings indicate no continuity, replace the bulb.

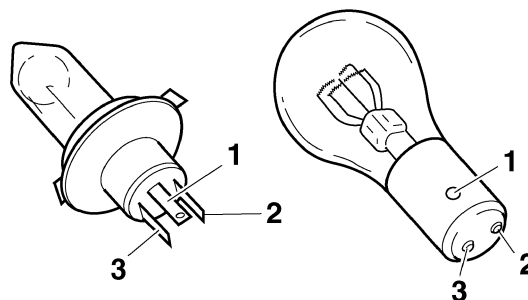

ELECTRICAL COMPONENTS

Checking the condition of the bulb sockets

The following procedure applies to all of the bulb sockets.

1. Check:
 - Bulb socket (for continuity) (with the pocket tester)
 No continuity → Replace.



**Pocket tester
90890-03112
Analog pocket tester
YU-03112-C**

TIP

Check each bulb socket for continuity in the same manner as described in the bulb section; however, note the following.

- a. Install a good bulb into the bulb socket.
- b. Connect the pocket tester probes to the respective leads of the bulb socket.
- c. Check the bulb socket for continuity. If any of the readings indicate no continuity, replace the bulb socket.

EAS28000

CHECKING THE FUSES

The following procedure applies to all of the fuses.

ECA13680

NOTICE

To avoid a short circuit, always set the main switch to “OFF” when checking or replacing a fuse.

1. Remove:
 - Battery cover
 Refer to “GENERAL CHASSIS” on page 4-1.
2. Check:
 - Fuse

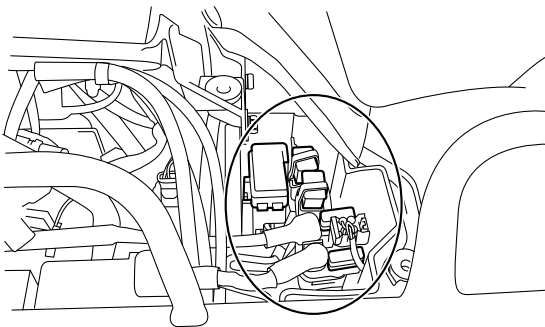

- a. Connect the pocket tester to the fuse and check the continuity.

TIP

Set the pocket tester selector to “Ω × 1”.



**Pocket tester
90890-03112
Analog pocket tester
YU-03112-C**

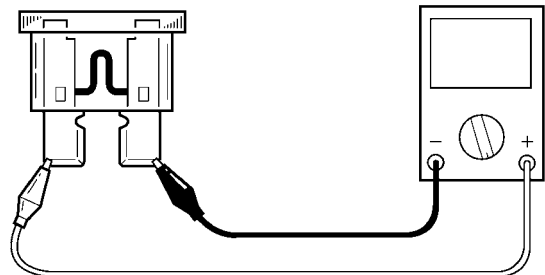

- b. If the pocket tester indicates “∞”, replace the fuse.

3. Replace:
 - Blown fuse

- a. Set the main switch to “OFF”.
- b. Install a new fuse of the correct amperage rating.
- c. Set the switch(es) to on to verify if the electrical circuit is operational.
- d. If the fuse immediately blows again, check the electrical circuit.

Fuses	Amperage rating	Q'ty
Main	40 A	1
EPS (for EPS models)	40 A	1
Radiator fan motor	20 A	1
Headlight	10 A	1
Ignition	10 A	1
Fuel injection system	15 A	1
Four-wheel-drive motor	10 A	1
Auxiliary DC jack	10 A	1
Signaling system	5 A	1
Spare	20 A	1
Spare	15 A	1
Spare	10 A	1
Spare	5 A	1

EWA13310

WARNING

Never use a fuse with an amperage rating other than that specified. Improvising or using a fuse with the wrong amperage rating may cause extensive damage to the electrical system, cause the lighting and ignition systems to malfunction and could possibly cause a fire.



4. Install:

- Battery cover
Refer to "GENERAL CHASSIS" on page 4-1.

EAS28030

CHECKING AND CHARGING THE BATTERY

EWA13290

WARNING

Batteries generate explosive hydrogen gas and contain electrolyte which is made of poisonous and highly caustic sulfuric acid. Therefore, always follow these preventive measures:

- Wear protective eye gear when handling or working near batteries.
- Charge batteries in a well-ventilated area.
- Keep batteries away from fire, sparks or open flames (e.g., welding equipment, lighted cigarettes).
- DO NOT SMOKE when charging or handling batteries.
- KEEP BATTERIES AND ELECTROLYTE OUT OF REACH OF CHILDREN.
- Avoid bodily contact with electrolyte as it can cause severe burns or permanent eye injury.

FIRST AID IN CASE OF BODILY CONTACT: EXTERNAL

- Skin — Wash with water.
- Eyes — Flush with water for 15 minutes and get immediate medical attention.

INTERNAL

- Drink large quantities of water or milk followed with milk of magnesia, beaten egg or vegetable oil. Get immediate medical attention.

ECA28P1002

NOTICE

- This is a VRLA (Valve Regulated Lead Acid) battery. Never remove the sealing caps because the balance between cells will not be maintained and battery performance will deteriorate.

- Charging time, charging amperage and charging voltage for a VRLA (Valve Regulated Lead Acid) battery are different from those of conventional batteries. The VRLA (Valve Regulated Lead Acid) battery should be charged as explained in the charging method. If the battery is overcharged, the electrolyte level will drop considerably. Therefore, take special care when charging the battery.

TIP

Since VRLA (Valve Regulated Lead Acid) batteries are sealed, it is not possible to check the charge state of the battery by measuring the specific gravity of the electrolyte. Therefore, the charge of the battery has to be checked by measuring the voltage at the battery terminals.

1. Remove:

- Battery cover
- Front carrier
- Battery holding bracket

Refer to "GENERAL CHASSIS" on page 4-1.

2. Disconnect:

- Battery leads
(from the battery terminals)

ECA13640

NOTICE

First, disconnect the negative battery lead "1", and then positive battery lead "2".

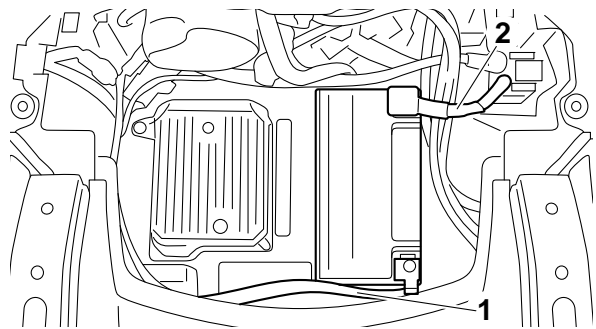

3. Remove:

- Battery

4. Check:

- Battery charge



a. Connect a pocket tester to the battery terminals.

- Positive tester probe → positive battery terminal
- Negative tester probe → negative battery terminal

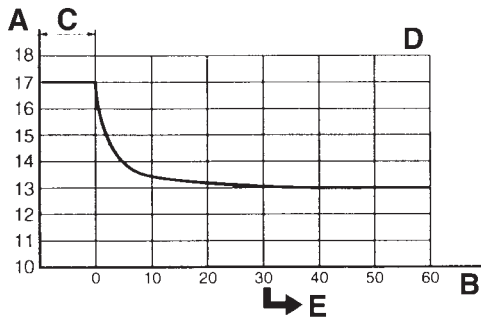

- A. Open-circuit voltage (V)
- B. Time (minutes)
- C. Charging
- D. Ambient temperature 20 °C (68 °F)
- E. Check the open-circuit voltage.

Charging method using a variable-current (voltage) charger

- a. Measure the open-circuit voltage prior to charging.

TIP _____
Voltage should be measured 30 minutes after the engine is stopped.

- b. Connect a charger and ammeter to the battery and start charging.

TIP _____
Set the charging voltage at 16–17 V. If the setting is lower, charging will be insufficient. If too high, the battery will be over-charged.

- c. Make sure that the current is higher than the standard charging current written on the battery.

TIP _____
If the current is lower than the standard charging current written on the battery, set the charging voltage adjust dial at 20–24 V and monitor the amperage for 3–5 minutes to check the battery.

- Reaches the standard charging current → Battery is good.
- Does not reach the standard charging current → Replace the battery.

- d. Adjust the voltage so that the current is at the standard charging level.
- e. Set the time according to the charging time suitable for the open-circuit voltage.

- f. If charging requires more than 5 hours, it is advisable to check the charging current after a lapse of 5 hours. If there is any change in the amperage, readjust the voltage to obtain the standard charging current.
- g. Measure the battery open-circuit voltage after leaving the battery unused for more than 30 minutes.

12.8 V or more --- Charging is complete.
12.7 V or less --- Recharging is required.
Under 12.0 V --- Replace the battery.

Charging method using a constant voltage charger

- a. Measure the open-circuit voltage prior to charging.

TIP _____
Voltage should be measured 30 minutes after the engine is stopped.

- b. Connect a charger and ammeter to the battery and start charging.
- c. Make sure that the current is higher than the standard charging current written on the battery.

TIP _____
If the current is lower than the standard charging current written on the battery, this type of battery charger cannot charge the VRLA (Valve Regulated Lead Acid) battery. A variable voltage charger is recommended.

- d. Charge the battery until its charging voltage is 15 V.

TIP _____
Set the charging time at 20 hours (maximum).

- e. Measure the battery open-circuit voltage after leaving the battery unused for more than 30 minutes.

12.8 V or more --- Charging is complete.
12.7 V–12.0 V --- Recharging is required.
Under 12.0 V --- Replace the battery.

6. Install:
 - Battery
7. Connect:
 - Battery leads (to the battery terminals)

ECA13630

NOTICE

First, connect the positive battery lead "1", and then the negative battery lead "2".

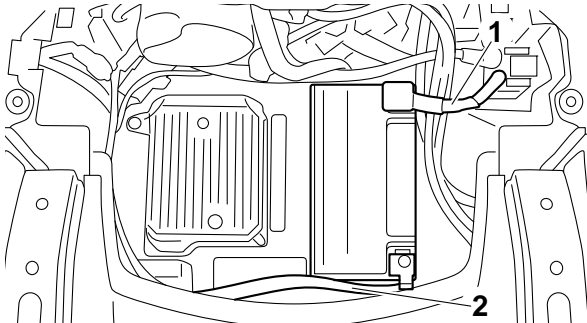

8. Check:

- Battery terminals
Dirt → Clean with a wire brush.
Loose connection → Connect properly.

9. Lubricate:

- Battery terminals



Recommended lubricant
Dielectric grease

10. Install:

- Battery holding bracket
- Front carrier
- Battery cover

Refer to "GENERAL CHASSIS" on page 4-1.

EAS28040

CHECKING THE RELAYS

Check each switch for continuity with the pocket tester. If the continuity reading is incorrect, replace the relay.

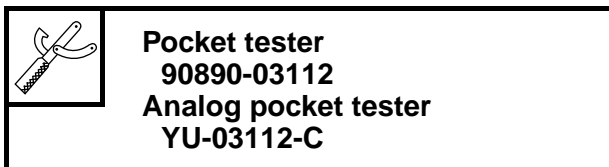

Pocket tester
90890-03112
Analog pocket tester
YU-03112-C

1. Disconnect the relay from the wire harness.
2. Connect the pocket tester ($\Omega \times 1$) and battery (12 V) to the relay terminal as shown.
Check the relay operation.
Out of specification → Replace.

Starter relay

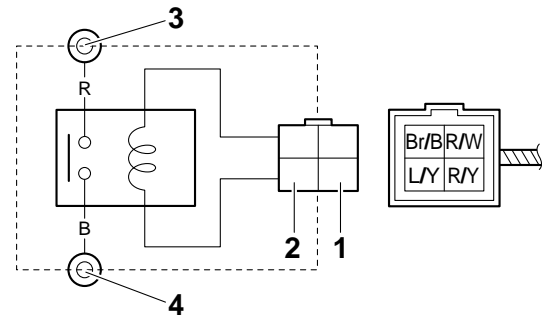

1. Positive battery terminal
2. Negative battery terminal
3. Positive tester probe
4. Negative tester probe

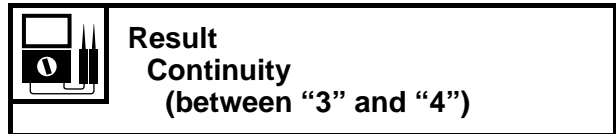

Result
Continuity
(between "3" and "4")

Headlight relay

First step:

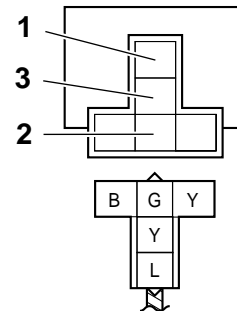

1. Positive tester probe
2. Negative tester probe
3. Negative tester probe

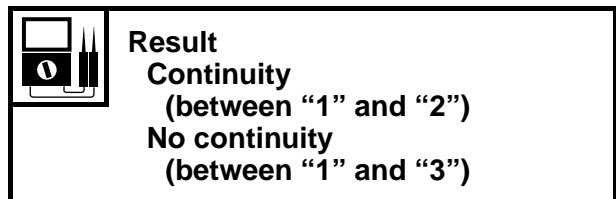

Result
Continuity
(between "1" and "2")
No continuity
(between "1" and "3")

ELECTRICAL COMPONENTS

Second step:

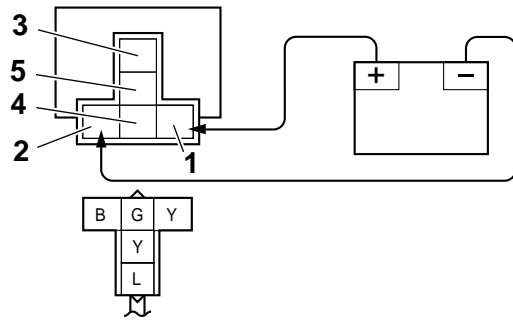

1. Positive battery terminal
2. Negative battery terminal
3. Positive tester probe
4. Negative tester probe
5. Negative tester probe



Result
No continuity
 (between "3" and "4")
Continuity
 (between "3" and "5")

Radiator fan motor relay

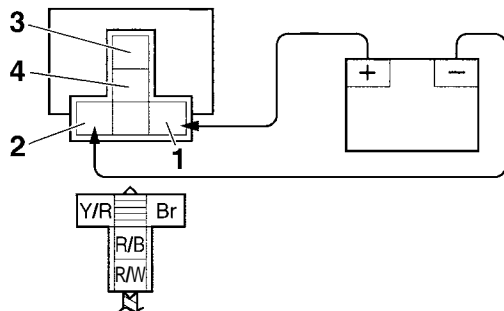

1. Positive battery terminal
2. Negative battery terminal
3. Positive tester probe
4. Negative tester probe



Result
Continuity
 (between "3" and "4")

Fuel injection system relay

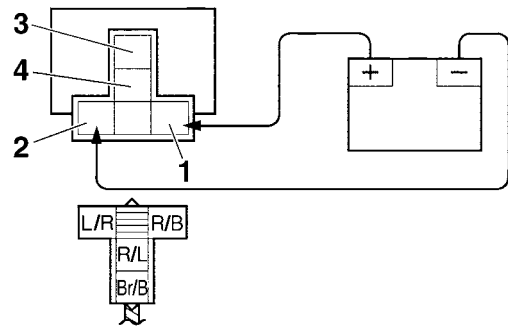

1. Positive battery terminal
2. Negative battery terminal
3. Positive tester probe
4. Negative tester probe



Result
Continuity
 (between "3" and "4")

Four-wheel-drive motor relay 1

First step:

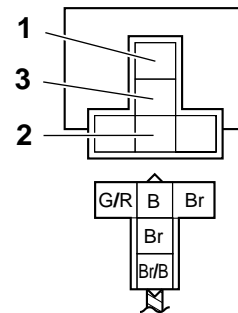

1. Positive tester probe
2. Negative tester probe
3. Negative tester probe



Result
Continuity
 (between "1" and "2")
No continuity
 (between "1" and "3")

ELECTRICAL COMPONENTS

Second step:

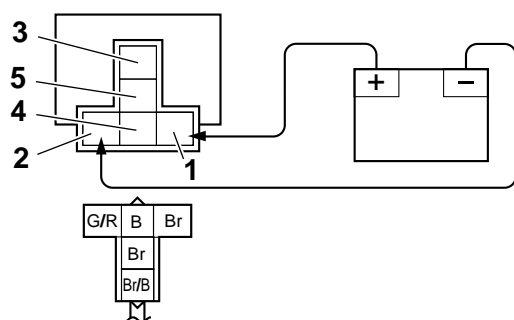

1. Positive battery terminal
2. Negative battery terminal
3. Positive tester probe
4. Negative tester probe
5. Negative tester probe



Result

No continuity
(between "3" and "4")
Continuity
(between "3" and "5")

Second step:

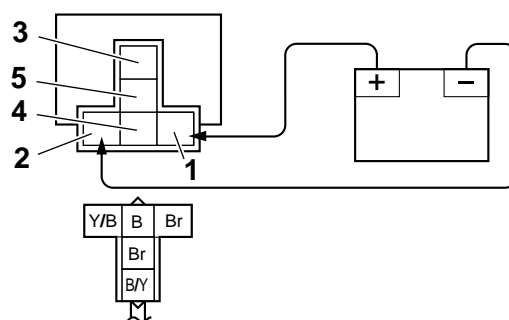

1. Positive battery terminal
2. Negative battery terminal
3. Positive tester probe
4. Negative tester probe
5. Negative tester probe



Result

No continuity
(between "3" and "4")
Continuity
(between "3" and "5")

Four-wheel-drive motor relay 2

First step:

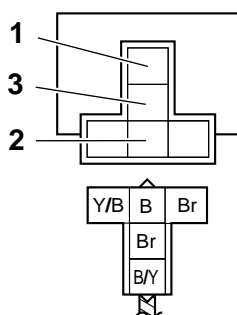

1. Positive tester probe
2. Negative tester probe
3. Negative tester probe



Result

Continuity
(between "1" and "2")
No continuity
(between "1" and "3")

EAS28050

CHECKING THE DIODE

1. Check:
 - Diode
 Out of specification → Replace.



Pocket tester
90890-03112
Analog pocket tester
YU-03112-C

TIP

The pocket tester or the analog pocket tester readings are shown in the following table.



No continuity
Positive tester probe →
black/yellow "1"
Negative tester probe → yellow
"2"
Continuity
Positive tester probe → yellow
"2"
Negative tester probe →
black/yellow "1"

ELECTRICAL COMPONENTS

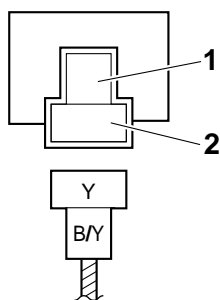

- a. Disconnect the diode from the wire harness.
- b. Connect the pocket tester ($\Omega \times 1$) to the diode coupler as shown.
- c. Check the diode for continuity.
- d. Check the diode for no continuity.

EAS28060

CHECKING THE SPARK PLUG CAP

1. Check:

- Spark plug cap resistance
Out of specification → Replace.

	Resistance 10.0 kΩ
--	---

- a. Remove the spark plug cap from the spark plug lead.
- b. Connect the pocket tester ($\Omega \times 1k$) to the spark plug cap as shown.

	Pocket tester 90890-03112 Analog pocket tester YU-03112-C
---	--

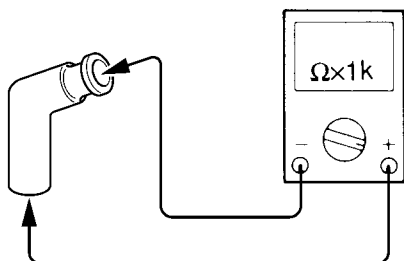

- c. Measure the spark plug cap resistance.

EAS28090

CHECKING THE IGNITION COIL

1. Check:

- Primary coil resistance
Out of specification → Replace.

	Primary coil resistance 2.16–2.64 Ω
---	--

- a. Disconnect the ignition coil connectors from the ignition coil terminals.
- b. Connect the pocket tester ($\Omega \times 1$) to the ignition coil as shown.

	Pocket tester 90890-03112 Analog pocket tester YU-03112-C
---	--

- Positive tester probe
red/black "1"
- Negative tester probe
orange "2"

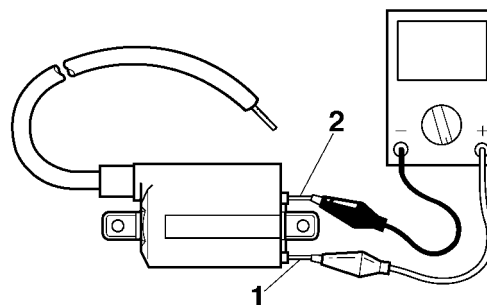

- c. Measure the primary coil resistance.

2. Check:

- Secondary coil resistance
Out of specification → Replace.

	Secondary coil resistance 8.64–12.96 kΩ
---	--

- a. Disconnect the spark plug cap from the ignition coil.
- b. Connect the pocket tester ($\Omega \times 1k$) to the ignition coil as shown.

	Pocket tester 90890-03112 Analog pocket tester YU-03112-C
---	--

- Positive tester probe
red/black "1"
- Negative tester probe
Spark plug lead "2"

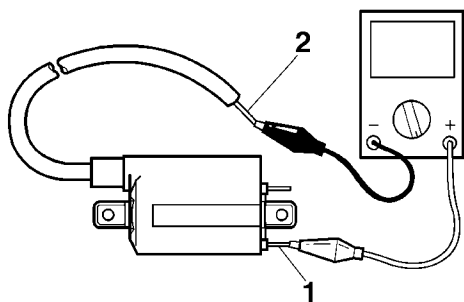

c. Measure the secondary coil resistance.

EAS28930

CHECKING THE IGNITION SPARK GAP

1. Check:

- Ignition spark gap
Out of specification → Perform the ignition system troubleshooting, starting with step 5. Refer to “TROUBLESHOOTING” on page 9-3.

	Minimum ignition spark gap 6.0 mm (0.24 in)
--	---

TIP

If the ignition spark gap is within specification, the ignition system circuit is operating normally.

- Disconnect the spark plug cap from the spark plug.
- Connect the ignition checker “1” as shown.

	Ignition checker 90890-06754 Oppama pet-4000 spark checker YM-34487
---	--

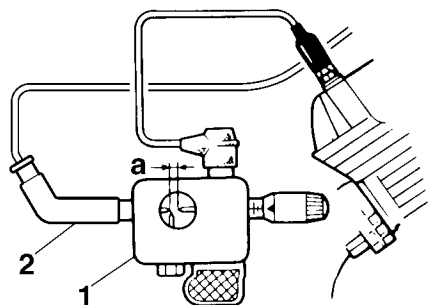

- Spark plug cap
- Set the main switch to “ON” and engine stop switch to “○”.
- Measure the ignition spark gap “a”.

- Crank the engine by pushing the start switch “⊞” and gradually increase the spark gap until a misfire occurs.

EAS28120

CHECKING THE CRANKSHAFT POSITION SENSOR

1. Disconnect:

- Crankshaft position sensor coupler (from the wire harness)

2. Check:

- Crankshaft position sensor resistance
Out of specification → Replace the crankshaft position sensor/stator assembly.

	Crankshaft position sensor resistance 459–561 Ω
---	---

- Connect the pocket tester ($\Omega \times 100$) to the crankshaft position sensor coupler as shown.

	Pocket tester 90890-03112 Analog pocket tester YU-03112-C
--	--

- Positive tester probe
gray “1”
- Negative tester probe
black “2”

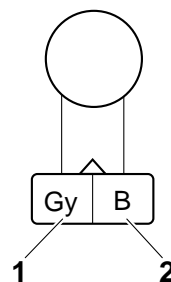

- Measure the crankshaft position sensor resistance.

EAS28130

CHECKING THE LEAN ANGLE SENSOR

1. Remove:

- Lean angle sensor

2. Check:

- Lean angle sensor output voltage
Out of specification → Replace.

ELECTRICAL COMPONENTS

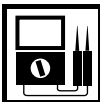

Lean angle sensor output voltage
 Less than 65°: 3.55–4.45 V
 More than 65°: 0.65–1.35 V

- a. Connect the lean angle sensor coupler to the wire harness.
- b. Connect the pocket tester (DC 20 V) to the lean angle sensor coupler as shown.



Pocket tester
 90890-03112
Analog pocket tester
 YU-03112-C

- Positive tester probe yellow/green "1"
- Negative tester probe black/blue "2"

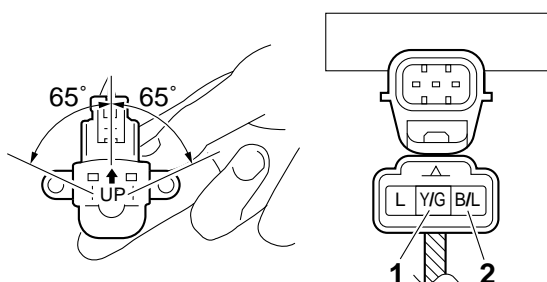

- c. Set the main switch to "ON".
- d. Tilt the lean angle sensor to 65°.
- e. Measure the lean angle sensor output voltage.

EAS28940

CHECKING THE STARTER MOTOR OPERATION

1. Check:
 - Starter motor operation
 Does not operate → Perform the electric starting system troubleshooting, starting with step 4.
 Refer to "TROUBLESHOOTING" on page 9-8.

- a. Connect the positive battery terminal "1" and starter motor lead "2" with a jumper lead "3".

EWA13810

WARNING

- A wire that is used as a jumper lead must have at least the same capacity of the battery lead, otherwise the jumper lead may burn.

- This check is likely to produce sparks, therefore, make sure no flammable gas or fluid is in the vicinity.

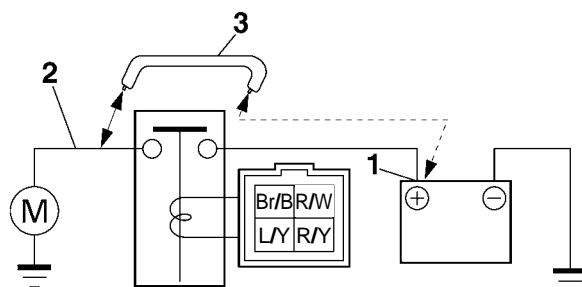

- b. Check the starter motor operation.

EAS28150

CHECKING THE STATOR COIL

1. Disconnect:
 - AC magneto coupler (from the wire harness)
2. Check:
 - Stator coil resistance
 Out of specification → Replace the crankshaft position sensor/stator assembly.



Stator coil resistance
 0.117–0.143 Ω

- a. Connect the pocket tester (Ω × 1) to the AC magneto coupler as shown.



Pocket tester
 90890-03112
Analog pocket tester
 YU-03112-C

- Positive tester probe white "1"
- Negative tester probe white "2"

- Positive tester probe white "1"
- Negative tester probe white "3"

- Positive tester probe white "2"
- Negative tester probe white "3"

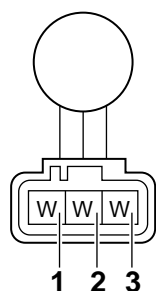

b. Measure the stator coil resistance.



EAS28170

CHECKING THE RECTIFIER/REGULATOR

1. Check:

- Charging voltage
Out of specification → Replace the rectifier/regulator.

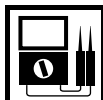

Charging voltage
above 14 V at 5000 r/min

- Connect the engine tachometer to the spark plug lead.
- Connect the pocket tester (DC 20 V) to the rectifier/regulator coupler as shown.



Pocket tester
90890-03112
Analog pocket tester
YU-03112-C

- Positive tester probe
red "1"
- Negative tester probe
black "2"

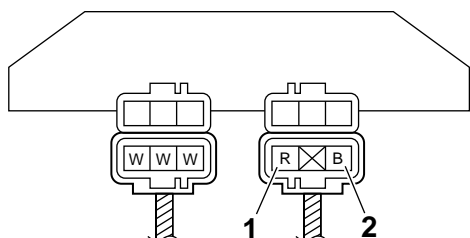

- Start the engine and let it run at approximately 5000 r/min.
- Measure the charging voltage.



EAS28230

CHECKING THE FUEL SENDER

- Disconnect:
 - Fuel pump coupler
(from the wire harness)
- Remove:
 - Fuel pump assembly
(from the fuel tank)
- Check:
 - Fuel sender resistance
Out of specification → Replace the fuel pump assembly.

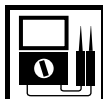

Sender unit resistance (full)
19.00–21.00 Ω
Sender unit resistance (empty)
139.00–141.00 Ω



- Connect the pocket tester ($\Omega \times 10$) to the fuel sender terminal as shown.



Pocket tester
90890-03112
Analog pocket tester
YU-03112-C

- Positive tester probe
green/yellow "1"
- Negative tester probe
black/white "2"

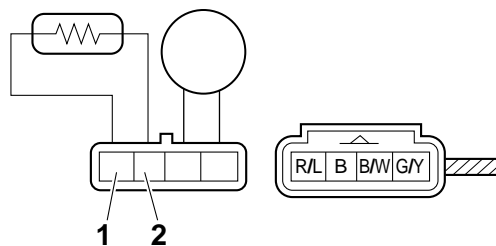

- Move the fuel sender float to the minimum "3" and maximum "4" level positions.

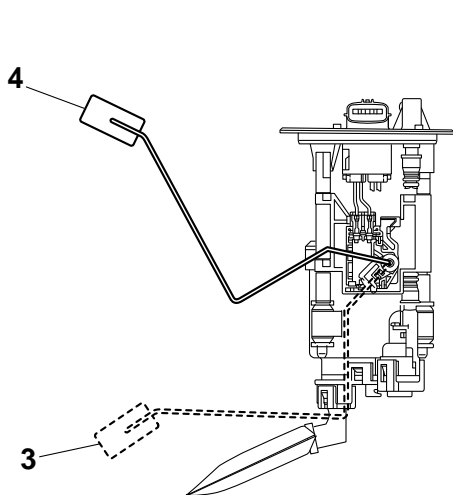

c. Measure the fuel sender resistance.

EAS28240

CHECKING THE SPEED SENSOR

1. Check:

- Speed sensor output voltage
Out of specification → Replace.

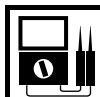

Output voltage reading cycle
0.6 V–4.8 V–0.6 V–4.8 V–0.6 V

a. Connect the pocket tester (DC 20 V) to the speed sensor coupler as shown.



Pocket tester
90890-03112
Analog pocket tester
YU-03112-C

- Positive tester probe
white "1"
- Negative tester probe
black/blue "2"

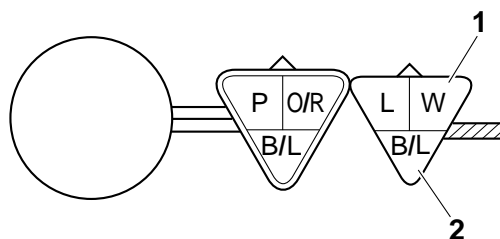

- Set the main switch to "ON".
- Elevate the rear wheels and slowly rotate them.
- Measure the voltage (DC 20 V) of white and black/blue. With each full rotation of the rear wheel, the voltage reading should cycle from 0.6 V to 4.8 V to 0.6 V to 4.8 V.

EAS28250

CHECKING THE RADIATOR FAN MOTOR

1. Check:

- Radiator fan motor
Faulty/rough movement → Replace.

a. Disconnect the radiator fan motor coupler from the wire harness.

b. Connect the battery (DC 12 V) as shown.

- Positive battery terminal
blue "1"
- Negative battery terminal
black "2"

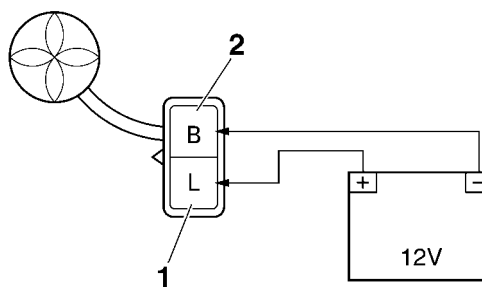

c. Measure the radiator fan motor movement.

EAS28P1001

CHECKING THE RADIATOR FAN MOTOR CIRCUIT BREAKER

1. Remove:

- Radiator fan motor circuit breaker
(from the wire harness)

ELECTRICAL COMPONENTS



Resistance
2.64–6.16 k Ω

- a. Connect the pocket tester ($\Omega \times 1k$) to the throttle position sensor terminal as shown.



Pocket tester
90890-03112
Analog pocket tester
YU-03112-C

- Positive tester probe blue "1"
- Negative tester probe black/blue "2"

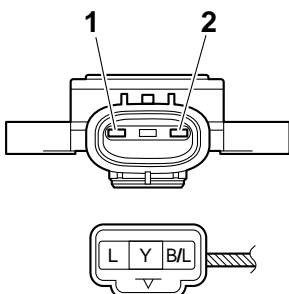

- b. Measure the throttle position sensor resistance.

3. Install:
- Throttle position sensor

TIP _____
When installing the throttle position sensor, adjust its angle properly. Refer to "ADJUSTING THE THROTTLE POSITION SENSOR" on page 7-7.

EAS28370
CHECKING THE AIR INDUCTION SYSTEM SOLENOID

1. Check:
- Air induction system solenoid resistance
Out of specification → Replace.



Solenoid resistance
20–24 Ω

- a. Disconnect the air induction system solenoid coupler from the wire harness.
b. Connect the pocket tester ($\Omega \times 1$) to the air induction system solenoid terminals as shown.



Pocket tester
90890-03112
Analog pocket tester
YU-03112-C

- Positive tester probe → Air induction system solenoid terminal "1"
- Negative tester probe → Air induction system solenoid terminal "2"

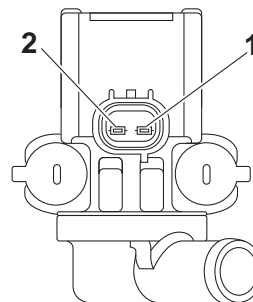

- c. Measure the air induction system solenoid resistance.

EAS28410
CHECKING THE INTAKE AIR PRESSURE SENSOR

1. Check:
- Intake air pressure sensor output voltage
Out of specification → Replace.



Intake air pressure sensor output voltage
3.75–4.25 V

- a. Connect the pocket tester (DC 20 V) to the intake air pressure sensor coupler as shown.



Pocket tester
90890-03112
Analog pocket tester
YU-03112-C

- Positive tester probe pink "1"
- Negative tester probe black/blue "2"

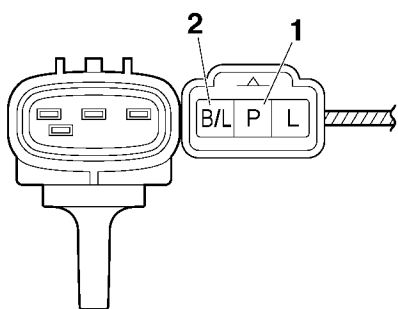

- b. Set the main switch to "ON".
- c. Measure the intake air pressure sensor output voltage.



EAS28420

CHECKING THE INTAKE AIR TEMPERATURE SENSOR

1. Remove:
 - Intake air temperature sensor (from the air filter case.)

EWA14110

WARNING

- Handle the intake air temperature sensor with special care.
- Never subject the intake air temperature sensor to strong shocks. If the intake air temperature sensor is dropped, replace it.

2. Check:
 - Intake air temperature sensor resistance Out of specification → Replace.

	<p>Intake air temperature sensor resistance 290–390 Ω at 80 °C (176 °F)</p>
---	--



- a. Connect the pocket tester ($\Omega \times 100$) to the intake air temperature sensor terminal as shown.

	<p>Pocket tester 90890-03112 Analog pocket tester YU-03112-C</p>
---	--

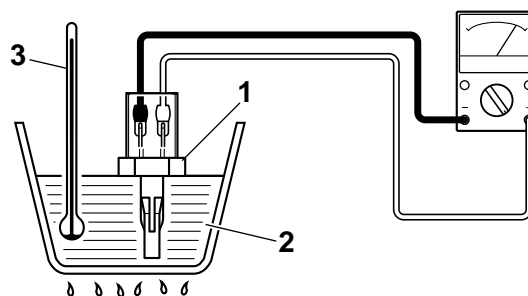

- b. Immerse the intake air temperature sensor "1" in a container filled with water "2".

TIP

Make sure that the air temperature sensor terminals do not get wet.

- c. Place a thermometer "3" in the water.
- d. Slowly heat the water, then let it cool down to the specified temperature.
- e. Measure the intake air temperature sensor resistance.



EAS1HPG018

CHECKING THE EPS MOTOR (for EPS models)

1. Remove:
 - EPS unit
2. Check:
 - EPS motor Out of specification → Replace the EPS unit.

TIP

The pocket tester and the analog pocket tester readings are shown in the following table.

	<p>Continuity Positive tester probe → red "1" Negative tester probe → black "2"</p> <p>No continuity Positive tester probe → red "1" Negative tester probe → EPS motor body "3"</p> <p>No continuity Positive tester probe → black "2" Negative tester probe → EPS motor body "3"</p>
---	--

TROUBLESHOOTING

TROUBLESHOOTING	10-1
GENERAL INFORMATION	10-1
STARTING FAILURES.....	10-1
INCORRECT ENGINE IDLING SPEED	10-1
POOR MEDIUM-AND-HIGH-SPEED PERFORMANCE	10-2
FAULTY DRIVE TRAIN	10-2
FAULTY GEAR SHIFTING.....	10-2
SHIFT LEVER DOES NOT MOVE	10-2
JUMPS OUT OF GEAR.....	10-2
FAULTY CLUTCH	10-3
OVERHEATING	10-3
OVERCOOLING.....	10-3
POOR BRAKING PERFORMANCE.....	10-4
FAULTY SHOCK ABSORBER ASSEMBLY.....	10-4
UNSTABLE HANDLING	10-4
FAULTY LIGHTING OR SIGNALING SYSTEM.....	10-4

EAS28451

TROUBLESHOOTING

EAS28460

GENERAL INFORMATION

TIP

The following guide for troubleshooting does not cover all the possible causes of trouble. It should be helpful, however, as a guide to basic troubleshooting. Refer to the relative procedure in this manual for checks, adjustments, and replacement of parts.

EAS28470

STARTING FAILURES

Engine

1. Cylinder and cylinder head
 - Loose spark plug
 - Loose cylinder head or cylinder
 - Damaged cylinder head gasket
 - Damaged cylinder gasket
 - Worn or damaged cylinder
 - Incorrect valve clearance
 - Improperly sealed valve
 - Incorrect valve-to-valve-seat contact
 - Incorrect valve timing
 - Faulty valve spring
 - Seized valve
2. Piston and piston ring(s)
 - Improperly installed piston ring
 - Damaged, worn or fatigued piston ring
 - Seized piston ring
 - Seized or damaged piston
3. Air filter
 - Improperly installed air filter
 - Clogged air filter element
4. Crankcase and crankshaft
 - Improperly assembled crankcase
 - Seized crankshaft

Fuel system

1. Fuel tank
 - Empty fuel tank
 - Clogged fuel tank drain hose
 - Clogged rollover valve
 - Clogged rollover valve hose
 - Deteriorated or contaminated fuel
2. Fuel pump
 - Faulty fuel pump
 - Faulty fuel injection system relay
 - Clogged or damaged fuel hose
3. Throttle body
 - Deteriorated or contaminated fuel

- Sucked-in air

Electrical system

1. Battery
 - Discharged battery
 - Faulty battery
2. Fuse(s)
 - Blown, damaged or incorrect fuse
 - Improperly installed fuse
3. Spark plug
 - Incorrect spark plug gap
 - Incorrect spark plug heat range
 - Fouled spark plug
 - Worn or damaged electrode
 - Worn or damaged insulator
 - Faulty spark plug cap
4. Ignition coil
 - Cracked or broken ignition coil body
 - Broken or shorted primary or secondary coils
 - Faulty spark plug lead
5. Ignition system
 - Faulty ECU
 - Faulty crankshaft position sensor
 - Broken AC magneto rotor woodruff key
6. Switches and wiring
 - Faulty main switch
 - Faulty engine stop switch
 - Broken or shorted wiring
 - Faulty gear position switch
 - Faulty start switch
 - Faulty brake light switch
 - Improperly grounded circuit
 - Loose connections
7. Starting system
 - Faulty starter motor
 - Faulty starter relay
 - Faulty starter clutch

EAS28490

INCORRECT ENGINE IDLING SPEED

Engine

1. Cylinder and cylinder head
 - Incorrect valve clearance
 - Damaged valve train components
2. Air filter
 - Clogged air filter element

Fuel system

1. Throttle body
 - Damaged or loose throttle body joint
 - Improper throttle cable free play
 - Flooded throttle body

Electrical system

1. Battery
 - Discharged battery
 - Faulty battery
2. Spark plug
 - Incorrect spark plug gap
 - Incorrect spark plug heat range
 - Fouled spark plug
 - Worn or damaged electrode
 - Worn or damaged insulator
 - Faulty spark plug cap
3. Ignition coil
 - Broken or shorted primary or secondary coils
 - Faulty spark plug lead
 - Cracked or broken ignition coil
4. Ignition system
 - Faulty ECU
 - Faulty crankshaft position sensor

- Broken AC magneto rotor woodruff key
5. Valve train
 - Improperly adjusted valve clearance
 - Improperly adjusted valve timing

EAS28510

POOR MEDIUM-AND-HIGH-SPEED PERFORMANCE

Refer to “STARTING FAILURES” on page 10-1.

Engine

1. Air filter
 - Clogged air filter element

Fuel system

1. Fuel pump
 - Faulty fuel pump

EAS30320

FAULTY DRIVE TRAIN

The following conditions may indicate damaged shaft drive components:

Symptoms	Possible Causes
<ol style="list-style-type: none"> 1. A pronounced hesitation or “jerky” movement during acceleration, deceleration, or sustained speed. (This must not be confused with engine surging or transmission characteristics.) 2. A “rolling rumble” noticeable at low speed; a high-pitched whine; a “clunk” from a shaft drive component or area. 3. A locked-up condition of the shaft drive mechanism, no power transmitted from the engine to the front and/or rear wheels. 	<ol style="list-style-type: none"> A. Bearing damage. B. Improper gear backlash. C. Gear tooth damage. D. Broken drive shaft. E. Broken gear teeth. F. Seizure due to lack of lubrication. G. Small foreign objects lodged between the moving parts.

TIP

Areas A, B, and C above may be extremely difficult to diagnose. The symptoms are quite subtle and difficult to distinguish from normal vehicle operating noise. If there is reason to believe these components are damaged, remove the components and check them.

EAS28530

FAULTY GEAR SHIFTING

Shifting is difficult

Refer to “FAULTY CLUTCH” on page 10-3.

Transmission

- Seized transmission gear
- Foreign object between transmission gears
- Improperly assembled transmission

EAS3B41028

SHIFT LEVER DOES NOT MOVE

Shift drum and shift forks

- Foreign object in a shift drum groove
- Seized shift fork
- Bent shift fork guide bar

EAS28550

JUMPS OUT OF GEAR

Shift forks

- Worn shift fork

Shift drum

- Incorrect axial play
- Worn shift drum groove

Transmission

- Worn gear dog

EAS28580

FAULTY CLUTCH

Engine operates but vehicle will not move

1. V-belt
 - Damaged or worn V-belt
 - Slipping V-belt
2. Primary pulley cam and primary pulley slider
 - Damaged or worn primary pulley cam
 - Damaged or worn primary pulley slider
3. Clutch spring(s)
 - Damaged clutch spring
4. Transmission gear(s)
 - Damaged transmission gear

Clutch slips

1. Clutch spring
 - Damaged, loose or worn clutch spring
2. Clutch shoe
 - Damaged or worn clutch shoe
3. Primary sliding sheave
 - Seized primary sliding sheave

Poor starting performance

1. V-belt
 - V-belt slips
 - Oil or grease on the V-belt
2. Primary sliding sheave
 - Faulty operation
 - Worn pin groove
 - Worn pin
3. Clutch shoe
 - Bent, damaged or worn clutch shoe

Poor speed performance

1. V-belt
 - Oil or grease on the V-belt
2. Primary pulley weight(s)
 - Faulty operation
 - Worn primary pulley weight
3. Primary fixed sheave
 - Worn primary fixed sheave
4. Primary sliding sheave
 - Worn primary sliding sheave
5. Secondary fixed sheave
 - Worn secondary fixed sheave
6. Secondary sliding sheave
 - Worn secondary sliding sheave

EAS28600

OVERHEATING

Engine

1. Clogged coolant passages
2. Cylinder head and piston
 - Heavy carbon buildup
3. Engine oil
 - Incorrect oil level
 - Incorrect oil viscosity
 - Inferior oil quality

Cooling system

1. Coolant
 - Low coolant level
2. Radiator
 - Damaged or leaking radiator
 - Faulty radiator cap
 - Bent or damaged radiator fin
3. Water pump
 - Damaged or faulty water pump
4. Thermostat
 - Thermostat stays closed
5. Hose(s) and pipe(s)
 - Damaged hose
 - Improperly connected hose
 - Damaged pipe
 - Improperly connected pipe

Fuel system

1. Throttle body
 - Damaged or loose throttle body joint
2. Air filter
 - Clogged air filter element

Chassis

1. Brake(s)
 - Dragging brake

Electrical system

1. Spark plug
 - Incorrect spark plug gap
 - Incorrect spark plug heat range
2. Ignition system
 - Faulty ECU

EAS28610

OVERCOOLING

Cooling system

1. Thermostat
 - Thermostat stays open

EAS28620

POOR BRAKING PERFORMANCE

- Worn brake pad
- Worn brake disc
- Air in hydraulic brake system
- Leaking brake fluid
- Faulty brake caliper kit
- Faulty brake caliper piston seal
- Loose union bolt
- Damaged brake hose
- Oil or grease on the brake disc
- Oil or grease on the brake pad
- Incorrect brake fluid level

EAS3B41029

FAULTY SHOCK ABSORBER ASSEMBLY

Leaking oil

- Bent, damaged or rusty damper rod
- Cracked or damaged shock absorber
- Damaged oil seal lip

Malfunction

- Fatigued or damaged shock absorber spring
- Bent or damaged damper rod

EAS28670

UNSTABLE HANDLING

1. Handlebar
 - Bent or improperly installed handlebar
2. Steering
 - Incorrect toe-in
 - Bent steering stem
 - Improperly installed steering stem
 - Damaged bearing or bearing race
 - Bent tie-rods
 - Deformed steering knuckles
3. Shock absorber
 - Faulty shock absorber spring
 - Leaking oil
4. Tire(s)
 - Uneven tire pressures (left and right)
 - Incorrect tire pressure
 - Uneven tire wear
5. Wheel(s)
 - Incorrect wheel balance
 - Deformed wheel
 - Damaged or loose wheel bearing
 - Bent or loose wheel axle
 - Excessive wheel runout
6. Frame
 - Bent frame
 - Damaged frame

EAS28710

FAULTY LIGHTING OR SIGNALING SYSTEM

Headlight does not come on

- Wrong headlight bulb
- Too many electrical accessories
- Hard charging
- Incorrect connection
- Improperly grounded circuit
- Poor contacts (main or light switch)
- Burnt-out headlight bulb

Headlight bulb burnt out

- Wrong headlight bulb
- Faulty battery
- Faulty rectifier/regulator
- Improperly grounded circuit
- Faulty main switch
- Faulty light switch
- Headlight bulb life expired

Tail/brake light does not come on

- Wrong tail/brake light bulb
- Too many electrical accessories
- Incorrect connection
- Burnt-out tail/brake light bulb

Tail/brake light bulb burnt out

- Wrong tail/brake light bulb
- Faulty battery
- Incorrectly adjusted rear brake light switch
- Tail/brake light bulb life expired

WIRING DIAGRAM**YF70GE/FM700DE 2014**

1. Crankshaft position sensor
2. AC magneto
3. Rectifier/regulator
4. Main switch
5. Main fuse
6. Battery
7. Fuel injection system fuse
8. Starter relay
9. Engine ground
10. Starter motor
11. Joint coupler
12. Fuel injection system relay
13. Yamaha diagnostic tool coupler
14. Reverse switch
15. ISC (idle speed control) unit
16. ECU (engine control unit)
17. Ignition coil
18. Spark plug
19. Fuel injector
20. Intake air temperature sensor
21. Coolant temperature sensor
22. Speed sensor
23. TPS (throttle position sensor)
24. Intake air pressure sensor
25. Lean angle sensor
26. Air induction system solenoid
27. Gear position switch
28. Horn switch (for Europe and Oceania)
29. Horn (for Europe and Oceania)
30. Meter assembly
31. Multifunction meter
32. Engine trouble warning light
33. Coolant temperature warning light
34. Park indicator light
35. Reverse indicator light
36. Neutral indicator light
37. High-range indicator light
38. Low-range indicator light
39. On-command four-wheel-drive motor switch and differential lock switch
40. Differential motor
41. Fuel sender
42. Fuel pump
43. Four-wheel-drive motor relay 1
44. Four-wheel-drive motor relay 2
45. Left handlebar switch
46. Override switch
47. Start switch
48. Engine stop switch
49. Light switch
50. Headlight
51. Headlight relay
52. Tail/brake light
53. Diode

54. Rear brake light switch
55. Front brake light switch
56. Radiator fan motor
57. Radiator fan motor circuit breaker
58. Radiator fan motor relay
59. Headlight fuse
60. Signaling system fuse
61. Ignition fuse
62. Four-wheel-drive motor fuse
63. Auxiliary DC jack fuse
64. Radiator fan motor fuse
65. Auxiliary DC jack
66. Frame ground 1
67. Frame ground 2
- A. Wire harness
- B. Negative battery sub-wire harness
- C. Wire harness (for CDN)
- D. Auxiliary DC jack lead (for CDN)
- E. for Europe and Oceania
- F. for CDN

COLOR CODE

B	Black
Br	Brown
G	Green
Gy	Gray
L	Blue
Lg	Light green
O	Orange
P	Pink
R	Red
Sb	Sky blue
W	White
Y	Yellow
B/G	Black/Green
B/L	Black/Blue
B/R	Black/Red
B/W	Black/White
B/Y	Black/Yellow
Br/B	Brown/Black
Br/L	Brown/Blue
Br/W	Brown/White
Br/Y	Brown/Yellow
G/R	Green/Red
G/W	Green/White
G/Y	Green/Yellow
Gy/G	Gray/Green
L/B	Blue/Black
L/R	Blue/Red
L/W	Blue/White
L/Y	Blue/Yellow
O/L	Orange/Blue
O/R	Orange/Red
P/L	Pink/Blue
P/W	Pink/White
R/B	Red/Black
R/G	Red/Green
R/L	Red/Blue
R/W	Red/White
R/Y	Red/Yellow
W/B	White/Black
W/G	White/Green
W/R	White/Red
Y/B	Yellow/Black
Y/G	Yellow/Green
Y/L	Yellow/Blue
Y/R	Yellow/Red
Y/W	Yellow/White

WIRING DIAGRAM**YF70GPPE/YF70GPHE/****YF70GPSE/YF70GPPE/****YFM700PE/YFM700PHE/****YFM700PSE/YFM700PLE 2014**

1. Crankshaft position sensor
2. AC magneto
3. Rectifier/regulator
4. Main switch
5. EPS fuse
6. Main fuse
7. Battery
8. Fuel injection system fuse
9. Starter relay
10. Engine ground
11. Starter motor
12. Joint coupler
13. EPS torque sensor
14. EPS motor
15. EPS (electric power steering) control unit
16. EPS self-diagnosis signal connector
17. Fuel injection system relay
18. Yamaha diagnostic tool coupler
19. Reverse switch
20. ISC (idle speed control) unit
21. ECU (engine control unit)
22. Ignition coil
23. Spark plug
24. Fuel injector
25. Intake air temperature sensor
26. Coolant temperature sensor
27. Speed sensor
28. TPS (throttle position sensor)
29. Intake air pressure sensor
30. Lean angle sensor
31. Air induction system solenoid
32. Gear position switch
33. Horn switch (for Europe and Oceania)
34. Horn (for Europe and Oceania)
35. Meter assembly
36. Multifunction meter
37. Engine trouble warning light
38. Coolant temperature warning light
39. Park indicator light
40. Reverse indicator light
41. Neutral indicator light
42. High-range indicator light
43. Low-range indicator light
44. EPS warning light
45. On-command four-wheel-drive motor switch and differential lock switch
46. Differential motor
47. Fuel sender
48. Fuel pump

49. Four-wheel-drive motor relay 1
50. Four-wheel-drive motor relay 2
51. Left handlebar switch
52. Override switch
53. Start switch
54. Engine stop switch
55. Light switch
56. Headlight
57. Headlight relay
58. Tail/brake light
59. Diode
60. Rear brake light switch
61. Front brake light switch
62. Radiator fan motor
63. Radiator fan motor circuit breaker
64. Radiator fan motor relay
65. Headlight fuse
66. Signaling system fuse
67. Ignition fuse
68. Four-wheel-drive motor fuse
69. Auxiliary DC jack fuse
70. Radiator fan motor fuse
71. Auxiliary DC jack
72. Frame ground 1
73. Frame ground 2
- A. Wire harness
- B. Negative battery sub-wire harness
- C. EPS (electric power steering) control unit
- D. Wire harness (for CDN)
- E. Auxiliary DC jack lead (for CDN)
- F. for Europe and Oceania
- G. for CDN

COLOR CODE

B	Black
Br	Brown
G	Green
Gy	Gray
L	Blue
Lg	Light green
O	Orange
P	Pink
R	Red
Sb	Sky blue
W	White
Y	Yellow
B/G	Black/Green
B/L	Black/Blue
B/R	Black/Red
B/W	Black/White
B/Y	Black/Yellow
Br/B	Brown/Black
Br/L	Brown/Blue
Br/W	Brown/White
Br/Y	Brown/Yellow
G/R	Green/Red
G/W	Green/White
G/Y	Green/Yellow
Gy/G	Gray/Green
L/B	Blue/Black
L/R	Blue/Red
L/W	Blue/White
L/Y	Blue/Yellow
O/L	Orange/Blue
O/R	Orange/Red
O/W	Orange/White
P/L	Pink/Blue
P/W	Pink/White
R/B	Red/Black
R/G	Red/Green
R/L	Red/Blue
R/W	Red/White
R/Y	Red/Yellow
W/B	White/Black
W/G	White/Green
W/R	White/Red
Y/B	Yellow/Black
Y/G	Yellow/Green
Y/L	Yellow/Blue
Y/R	Yellow/Red
Y/W	Yellow/White

YF70GE/YFM700DE 2014 WIRING DIAGRAM

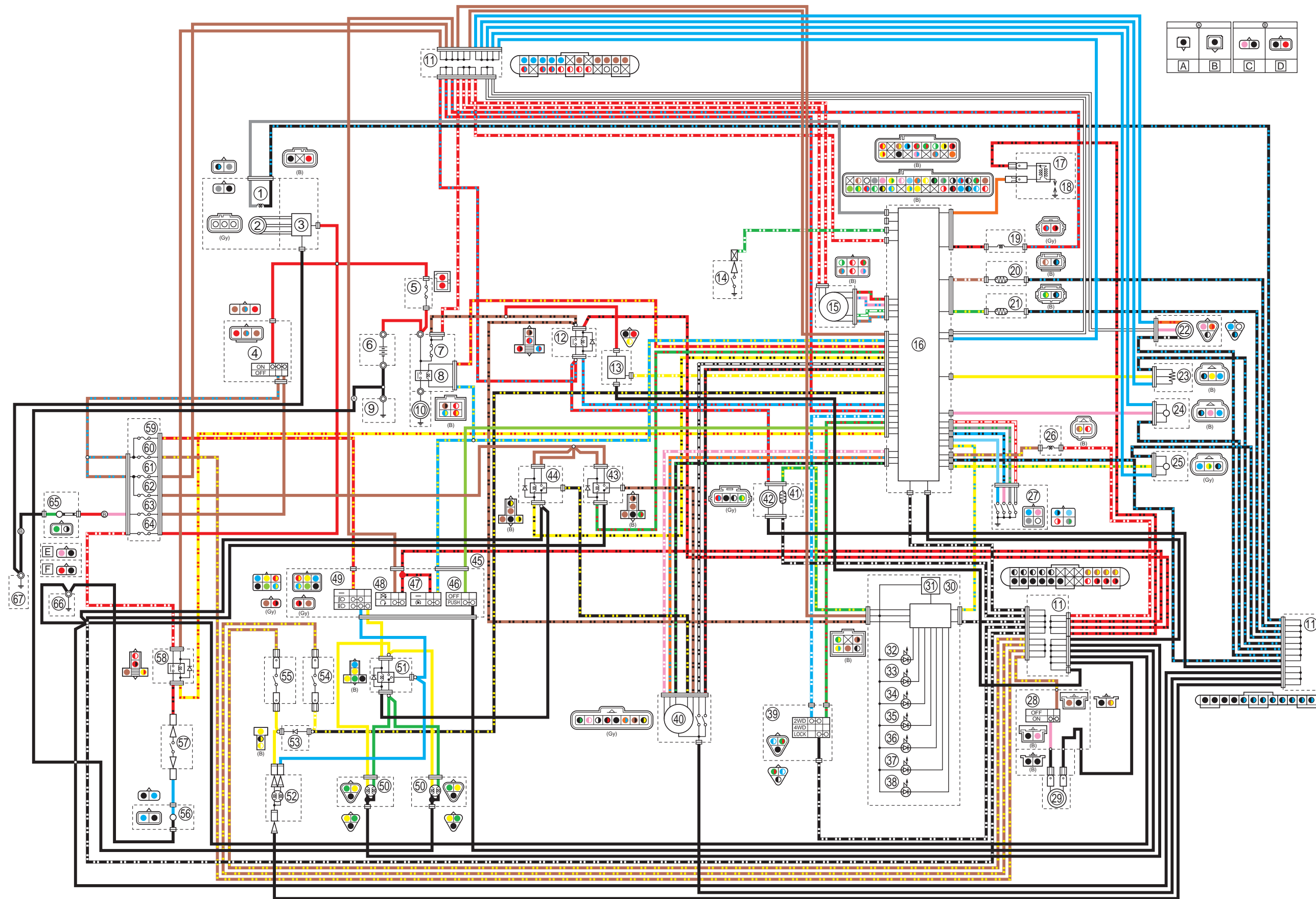

YF70GPE/YF70GPHE/YF70GPSE/YF70GPPE/YFM700PE/YFM700PHE/YFM700PSE/YFM700PLE 2014 WIRING DIAGRAM

